

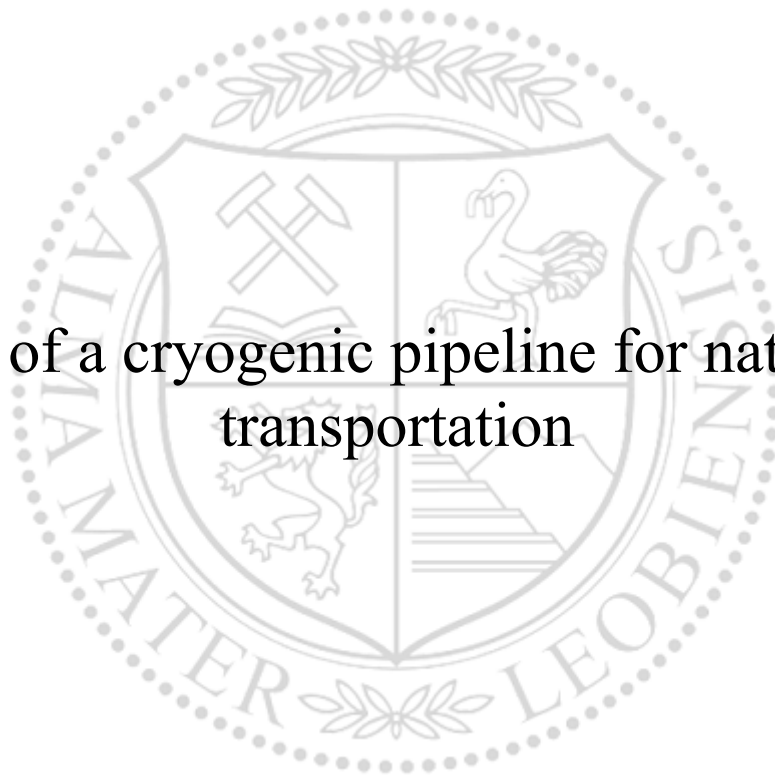

Chair of Petroleum and Geothermal Energy Recovery

Master's Thesis

Design of a cryogenic pipeline for natural gas
transportation



Nikolay Dudnikov

June 2021



AFFIDAVIT

I declare on oath that I wrote this thesis independently, did not use other than the specified sources and aids, and did not otherwise use any unauthorized aids.

I declare that I have read, understood, and complied with the guidelines of the senate of the Montanuniversität Leoben for "Good Scientific Practice".

Furthermore, I declare that the electronic and printed version of the submitted thesis are identical, both, formally and with regard to content.

Date 17.06.2021

A handwritten signature in black ink, appearing to be 'N. Dudnikov', written over a horizontal line.

Signature Author
Nikolay Dudnikov

Kurzfassung

Um Flüssiggas effizient zu transportieren, ist es heutzutage notwendig, diesen Zweig des kryogenen Pipelinetransports zu entwickeln. Es ist wichtig, ein Transportschema für die Lieferung von Flüssiggas zu entwickeln. Der Vorteil des Transports von Flüssiggas durch eine Rohrleitung ist eine hohe Produktivität und Durchsatz bei kleinen Durchmessern. Diese Arbeit sollte die Frage nach der Möglichkeit des Transports von assoziiertem Erdölgas in verflüssigter Form durch die Trunk-kryogene Pipeline von Ölfeldern beantworten, die sich in großer Entfernung vom Industriezentrum befinden, und die Frage nach der Stärke der kryogenen Pipeline. Die Hauptschwierigkeit beim Bau einer kryogenen Rohrleitung ist der enorme Temperaturunterschied zwischen dem transportierten Flüssiggas und der Umwelt, da die Rohrleitung von gefährlichen Zug- und Drucklängsspannungen betroffen ist.

Der Zweck der Untersuchung ist die Feststellung der Wirkung der Belastung von der Temperaturdifferenz auf die kryogene Rohrleitung, Optimierung in Bezug auf die Auswahl der optimalen elastischen Biegung zur Erhaltung der Festigkeit und der Beständigkeit des Bauwerks. Auch die Feststellung der Parameter des Ausgleichs der Längszugspannungen und Längsdruckspannungen durch den geradlinigen oberirdischen Bereich der kryogenen Rohrleitung mit dem schwachgebogenen Ausgleichsbereich.

Zur Durchführung der Festigkeitsberechnung in dieser Arbeit wurde der moderne Programmkomplex des Systems für die Analyse der Endelemente Ansys angewendet. Die Hauptaufgabe bei der der Festigkeitsberechnung besteht in der Feststellung und der Optimierung der Projektparameter, bei denen die Bedingung der doppelten Festigkeitsreserve der kryogenen Rohrleitung bei der Einwirkung der Belastungen von der Temperaturdifferenz darauf eingehalten werden wird. Zur Lösung dieser Aufgabe ist ein Modell im Berechnungsmedium Ansys entwickelt, mit dem Verfahren der Endelemente, des elastisch gebogenen Bereichs der Sektionen der kryogenen Rohrfernleitung, der in Baueinheiten für die Montage der Absperrarmatur sowie für den Ausgleichsbereich hart befestigt ist.

Als Ergebnis der Untersuchung wurden zulässige Radien der elastischen Biegung bestimmt, genau bestimmte Berechnungen der Dicken der Wände für unterschiedliche Sektionen der kryogenen Rohrfernleitung angeführt, mit der sich ändernden Temperaturdifferenz im Prozess der Beförderung des verflüssigten Erdölbegleitgases. Der Aufbau des Ausgleichsbereichs und seine Berechnung für die verantwortungsvollste Sektion der kryogenen Rohrfernleitung wurden gewählt.

Abstract

Nowadays, in order to efficiently transport liquefied gas, it is necessary to develop this branch of cryogenic pipeline transportation. It is important to develop a transport scheme for the delivery of liquefied gas. The advantage of transporting liquefied gas through a pipeline is high productivity and throughput at small diameters. This work should answer the question of the possibility of transporting associated petroleum gas in liquefied form through the trunk cryogenic pipeline from oil fields that are located at long distances from the centre of industry and the question of the strength of the cryogenic pipeline. The main difficulty of construction a cryogenic pipeline is the huge temperature difference between the transported liquefied gas and the environment, as the pipeline will be affected by dangerous tensile and the compressive longitudinal stresses.

The purpose of the study is to determine the effect of the load from the temperature difference on the cryogenic pipeline, optimizing the selection of the optimal elastic bending to maintain the strength and stability of the structure. Also determination of compensation parameters from longitudinal tensile and compressive stresses by means of rectilinear above-ground section of cryogenic pipeline with slightly bent compensation section.

To perform strength calculation in this work, a modern software complex of the Ansys finite-element analysis system is used. The main task in strength calculation is to determine and optimize the design parameters under which the condition of double safety factor of the cryogenic pipeline will be met when exposed to loads from the temperature difference. To solve this problem, in the design environment of Ansys, a model was developed using the finite element method, elastically curved section of sections of the main cryogenic pipeline rigidly fixed in the units of the shutoff valves installation, as well as the compensation section.

As a result of the study, permissible elastic bending radius were determined, refined calculations of wall thicknesses for various sections of the main cryogenic pipeline with a varying temperature difference during the transportation of liquefied associated petroleum gas were given. The design of the compensating section and its calculation for the most responsible section of the main cryogenic pipeline are selected.

Table of Content

	Page
1 INTRODUCTION.....	1
2 LITERATURE REVIEW	3
2.1 Relevance of production and application of LNG pipeline transport	3
2.2 Provision of LNG transport.....	10
2.3 Features of cryogenic fluids transport.....	15
2.4 Design features of cryogenic LNG pipelines.....	18
2.5 Interaction of underground pipeline and permafrost soil	33
2.6 Basis of calculation of strength and stability of cryogenic LNG pipelines.....	37
3 THEORETICAL AND DESIGN BASIS	41
3.1 Theoretical basis of strength calculation	41
3.2 Characteristics of the construction area.....	44
3.3 Determination of critical conditions and thermohydraulic parameters of non-thermal LAPG transfer mode	47
4 STRENGTH CALCULATION AND DESIGN OPTIMIZATION FOR LAPG CRYOGENIC PIPELINE	52
4.1 Initial data for simulation	52
4.2 Determination of compensation section parameters for section 0-20 km of cryogenic pipeline	78
5 RESULTS	84
6 CONCLUSION	85
REFERENCES	86
LIST OF TABLES	90
LIST OF FIGURES	93
ABBREVIATIONS	95
NOMENCLATURE	96

1 Introduction

The urgent need to develop the production and transportation of LNG is growing rapidly, as the population's demand for electricity is growing, and the most environmentally friendly resource for its production is natural gas. This global trend leads to a widespread increase in the volume of production and import of the resource in question. Analyzing the advantages and disadvantages of the gaseous and liquefied state of natural gas, the key ones are its transportation and operation parameters. The undeniable advantage of LNG transportation is the volume occupied by it, the value of which is 600 times less than the gaseous state.

Natural gas is pure fuel (clean energy). Coming to the consumer, it does not contain heavy metals, sulfur and other harmful impurities released after combustion.

Methane is a universal product and, depending on the state, a universal transport unit. Versatility, on the one hand, is that it can be used in the production of heat, electricity, technical processes, on the other hand, in the liquefied state it can be used as fuel in domestic conditions, as well as clean fuel for cars, locomotives, aircraft, river and sea vessels, agricultural machinery and transported, along with pipeline, all these modes of transport. Therefore, all developed countries have been striving since the beginning of the 21st century to have natural gas as a fuel, mainly in a liquefied state.

The Russian Federation has the largest reserves of natural gas and is also a major consumer and export supplier. The question of the most efficient way to transport it remains always relevant. In addition, due to the huge size of the country, some potential consumers, located at an impressive distance from the places of production and processing, are not able to take advantage of such a type of fuel as gas. Any positive implementations in gas transport technology contribute to the development not only of the country's economy, but also of infrastructure and economy in territories remote from the center of production.

Since the 1970s, in Russia, along with the creation of new technologies for the construction, transport, structures of pipelines of large diameter and pressure, the direction of creating systems and facilities for liquefied natural gas began to develop. Together with the improvement and development of new and efficient technologies for transporting gas through gas pipelines of large diameter and pressure, a start was made in the development of gas liquefaction technologies. Today, a new «Arctic LNG-2» natural gas liquefaction plant is being built on the Gydan Peninsula, which will increase productivity in the production and transportation of LNG using tankers.

Since the experience of gas pumping shows that the lowest losses are achieved in pipeline transport, the question arises about the advisability of transporting LNG through cryogenic pipelines, the diameter of which will be several times smaller, and the throughput is greater. The main deterrent to the introduction of cryogenic heat-insulated pipelines is the lack of developments and rules for the construction of such as: theories for calculating the strength and stability of a cryogenic pipeline with an impressive heat-insulating coating when exposed to constant and temporary loads, effective structures that can compensate for deformations

caused by temperature differences, as well as studies of the behavior of steel material in such extreme conditions. Questions remain about effective methods of construction and application of methods of LNG pipeline monitoring and diagnostics and product retention of cryogenic temperature for the entire transport distance. It is important to study potential accidents on the LNG pipeline.

In the work, a set of modern software were used to determine and evaluate the load capacity of a cryogenic pipeline and determine the main elements of the structure for a stressed-deformed state, as well as the behavior of liquefied gasoline gas during its transportation to a given distance.

Such a study is required to assess the rationality of the implementation of the LNG pipeline into the energy network and the methods of its construction.

The approach to calculating the strength of the LNG wire itself is ambiguous. On the one hand, at LNG temperature, the resistance of steel increases by 1.2-1.3 times, which allows reducing the wall thickness by 1.10-1.25 times than that of a gas-oil pipeline. Operating stresses will always be tensile due to unambiguous stresses caused by negative temperature drop and internal pressure. On the other hand, in the first seconds of starting the LNG wire, intensive evaporation and steam overheating occur, the LNG advance slows down and a phase transition occurs. At the same time, the pressure at the front of the stream can increase and even exceed the inlet pressure. This phenomenon is dangerous, therefore, before the development of practical experience, it is necessary to introduce a sufficiently large overload factor into calculations for experimental LNG pipelines (unlike regulatory documents adopted for the construction of traditional gas pipelines). Double safety factor shall be used.

In the pinched pipeline, unacceptable longitudinal stresses arise, the reduction of which is possible, first of all, by using compensation devices and providing, in each case, a monolithic or sliding interaction circuit on the pipe - heat insulation section.

2 Literature review

2.1 Relevance of production and application of LNG pipeline transport

2.1.1 State of the LNG industry

Over the past century, the growth of mankind's energy consumers has far outpaced the exponent of the growth of the world's population. According to experts, until 2025, energy consumption in the world will increase one and a half times. The vast majority of the increase in demand for primary energy sources will continue to be met by fossil fuels - oil, gas and coal. Renewable sources of energy (wind, solar, hydrogen, etc.) in the foreseeable future will not replace traditional fuels, the use of which gradually shifts the emphasis from coal to oil and to more environmentally friendly carriers, especially gas. Alternative sources of energy, such as nuclear energy, are either unacceptable and have too high risks associated with the proliferation of hazardous materials or are not commercially feasible worldwide.¹

Modern civilization needs fast-growing energy supplies, while energy consumption is the main indicator not only of the industrial, but also of the economic development of the countries of the world, and their social well-being.

As civilization develops, its dependence on energy, on energy sources, also grows. Each new technical cycle has not only qualitative changes in the structure of use and types of energy resources, but also a quantitative increase in energy consumption, which increases many times.

The progress of the world community was predetermined by the fact that man was able to transform and benefit from primary fuel energy resources: coal, oil and natural gas. The degree and dynamics of economic development are due to the development of energy, which includes all fuel industries, covers mining, processing, transportation and storage activities. Primary energy resources, power generation and transmission. Interacting with each other, all these industries form a single fuel and energy complex, which is allocated the most important place in the economy of any country, without it the normal functioning of the modern state is impossible.

The natural gas market is the youngest. From its inception to the present, it is developing intensively. The techno-economic and consumer properties of gas have contributed to its widespread use in almost all areas of energy consumption. The share of gas in global energy consumption is growing at a rapid pace. By the end of the 20th century, along with the traditional North American gas market, the European market was fully formed and the liquefied gas market in the Asia-Pacific region was developing intensively.

¹ Makarov, E. 1970. Process strength of steel during austenite transformations (cold cracks). Mechanical engineering, vol.12, pp.54-62.

The natural gas market actually consists of two markets: the natural gas market and the liquefied natural gas (LNG) market. The main and largest exporter of natural gas is currently Russia, which provides more than 36% of world exports. The rapid growth of LNG trade and its increased competition with natural gas are becoming increasingly significant factors in the international gas business. The implementation of LNG projects is a promising area, which will allow greater flexibility in working in export markets.

The development and transportation of gas from Russian Arctic fields will be much more difficult than in any of the modern production areas. In this regard, LNG has an undeniable advantage among other energy sources - environmental fuel, convenient and efficient in storage and during transportation. The development of new technologies for gas production and transportation, especially over long distances, to some extent remove the "regional framework."

At the beginning of the 21st century, the LNG industry became a leader in growth rates among other sectors of the global fuel and energy complex. LNG becomes an alternative where there are long distances and complexity of natural conditions.

The history of the LNG industry shows that technology is developing faster than oil production and processing technology.

The gas industry is one of the most important sectors of our country's economy. Russia has the largest industrial reserves of hydrocarbon gases (more than 30% of the world) and occupies a leading position in their production and export. Currently, there are two technologies for transporting natural gas: pipeline transport and transportation in the form of liquefied natural gas (LNG).

One of the fastest developing areas of the fuel and energy complex of the Russian Federation and the world as a whole is the production and transportation of liquefied natural gas. Currently, more than 30% of the produced gas is transported in liquefied form. The average annual increase in such transportation volumes is 7-8%.²

There are 16 LNG exporting countries and 19 LNG importing countries worldwide.³ Among the largest LNG exporters are countries such as Qatar, Malaysia and Indonesia. The three largest importers were Japan, South Korea and Spain. Today, the LNG trading market in the world is developing at an accelerated pace (Figure 1). So, by 2030, it is predicted that LNG will occupy a share of 60% of the total global gas trade.

² Rachevskiy, B. 2009. Liquefied hydrocarbon gas. Moscow: Oil And Gas, 640 pages.

³ Vovk, V., Nikitin, B., Novikov, A., Grechko, A. 2011. Large-scale production of liquefied natural gas. Textbook for universities, Moscow: Nedra.

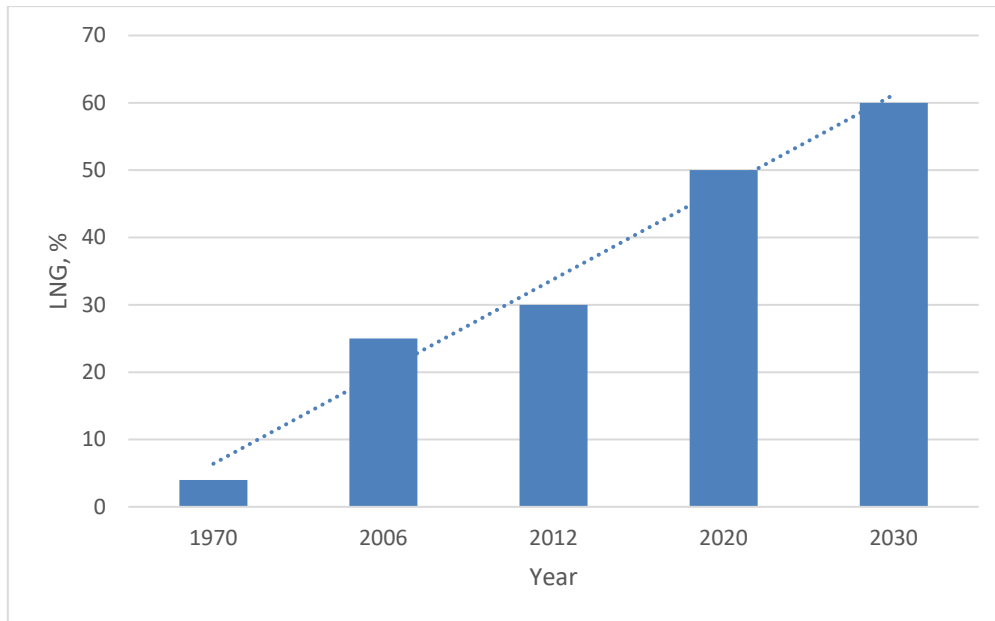

Figure 1: LNG share in global gas trade⁴

LNG transport plays an important role in the LNG supply chain. Transportation of liquefied gases is carried out in the following ways:

- by rail in special tank cars and wagons loaded with cylinders;
- Motor vehicles in special tank-vehicles, tank-containers and vehicles loaded with tanks and cylinders;
- by sea on special tanker vessels and container ships loaded with tank containers;
- by river transport on tankers, container ships and barges loaded with tanks, cylinders and tank containers;
- air transport in cylinders;
- via technological pipelines.⁵

The use of LNG as motor fuel for various types of vehicles (road, air, rail, water, etc.) provides energy and environmental benefits and is more cost-effective than traditional petroleum and other alternative motor fuels.⁶

In the United States, up to 25% of municipal vehicles have been transferred to LNG, more than 600 quarry dump trucks, buses, cargo loaders, ships, and diesel locomotives work. In

⁴ Nikolaev, A., Dokukin, V., Voronov, V. 2012. Analysis of existing methods for calculation of liquefied natural gas transfer modes through pipelines. Notes of the Mining Institute, vol.4, iss.199, pp.357-359.

⁵ Rachevskiy, B. 2009. Liquefied hydrocarbon gas. Moscow, OilAndGas, 640 pages.

⁶ Kirillov, N. 2003. Liquefied natural gas as a fuel for vehicles in Russia. Energy and Industry of Russia, vol.1, pp. 19-27.

Western Europe, a number of firms are actively involved in the introduction of LNG in vehicles.⁷ The use of LNG in rail transport is also expanding.

The geographical location of the main gas-bearing provinces of Russia is such that until now natural gas transport from well to consumer must be carried out through gas pipelines, unlike developed western countries, which transport gas in large volumes from overseas in liquefied form by tankers.

Due to the development of technological schemes for the production and transport of LNG, pipelines were created mainly by Western countries, the USA and Japan for transshipment of LNG from liquefaction plants of various cycles into methane tankers, and from them into storage facilities built by various methods that are not acceptable for Russian conditions.

High energy losses for natural gas pumping in the usual state, high costs of pipe steels and, above all, high environmental friendliness of LNG, led not only all developed countries, but also Russia to widespread use of LNG. Liquefied natural gas is a universal transport unit. It can be transported by almost any mode of transport (road, rail, water, air, pipeline)⁸, due to the high stability of the liquid phase of natural gas (under atmospheric conditions, but with some supercooling and with effective thermal insulation). However, preference should be given to pipeline transport.⁹

Liquefied natural gas pipelines are used by the above mentioned countries not only to transfer LNG to tankers and to regasification points, but also to transfer cryogenic liquids (hydrogen, nitrogen, oxygen, etc.)¹⁰ through inter-mill process pipelines. At the same time, pipelines are, in some cases, very simple, sometimes even without elementary heat insulation coating, if cryogenic liquid is transported periodically and over short distances (with supercooling), or very complex, for example, with vacuum insulation, in the case of supply of coolant in potentially dangerous sections of the route. But these expensive pipelines, due to the small structural and material volume in the structure, have, as a rule, an invisible amount of financial costs compared to the large amount of all costs for the entire complex of the facility. In addition, they are usually above ground, rarely underwater, and are operated in a temperate, user-friendly climate.

⁷ Barmin, I., Chechulin Y., Kunis, I. 1996. Liquefied Natural Gas - Alternative Energy and Affordable Fuel. Refrigerating case, vol.3, pp.67-71.

⁸ Dobrovolskiy, G. 1976. Determination of the state parameters of liquefied natural gas during its movement through the pipeline. AN USSR

⁹ Ilyinskiy, A. 1976. Transport and storage of industrial liquefied gases. Chemistry, vol.5, pp.9-16.

¹⁰ Zatsepin, A. 1977. Development of the technology of construction of main pipelines of low-water and cooled natural gas. Moscow, VNIIST.

Pipeline transport of supercooled liquids with a low boiling point (-80...-200°C) was previously used only for technological purposes. Liquefied methane is transported within transshipment bases and liquefaction plants, as well as from liquefaction plants to gas storage facilities. For example, the length of two vacuum-insulated piping systems for pumping liquid oxygen with a temperature of -180°C (England) did not exceed 25 km. As of 1968, there was a 6-inch pipeline in the United States for transporting liquid oxygen from liquefaction plants to an experimental 2.2 km¹¹ engine bench. The above-mentioned cryogenic pipelines of the USA, England, etc. are made of expensive and scarce materials do not provide sufficient representation for the design, operation and construction of low-temperature main pipelines in Russia.¹² Currently, there is little experience in transporting liquefied methane through main pipelines.¹³

The United States has the most developed long-range liquefied petroleum gas pipeline network. Among the active pipelines is the 1,770 km Houston (Texas) - Danville (Virginia) highway. In 1960, the Mid-American main pipeline for liquefied gas (mainly propane) and light oil products was put into operation. The total length of the highway is 3500 km, its capacity is 13500 m³/day. The 400 km main pipeline, laid between the cities of Wood River and Chicago, has been in operation since 1940 and is used to pump liquefied gases and other light petroleum distillation products.

Pipeline transport of liquefied gases in Russia has received significant development. Most of the existing Russian pipelines for the transport of liquefied gases are used for domestic needs, as well as for the transport of these gases from their place of production to chemical plants where liquefied gases serve as raw materials. The Tuymazy-Ufa gas pipeline for the supply of liquefied gas was built; the length of the highway is 172 km, diameter 250 mm. It is envisaged to supply a number of gas filling stations from this gas pipeline that provide refueling of vehicles converted to propane-butane fuel. Through the pipeline from Minnibaev to Kazan (length 300 km, diameter 275 mm, capacity 400 thousand tons/year), liquefied gas is pumped from the gas processing plant (GPP) to the Kazan Organic Synthesis Plant (Kazanorgsintez).

¹¹ Alexandrov, A., Benyaminovich, O., Odishariya, G., Gudkov, S., Hodanovich, I. 1968. Problems of transport and use of natural gas in liquefied and refrigerated conditions. Moscow, VNIIGAS, pp.42-49.

¹² Akulykina, N., Andrianov, V., Zorkaltsev, V., Larionov, Logvin, G., Polozov, Fot, N., Sharigin, V. 1988. Refrigerated and liquefied natural gas main pipelines. Syktyvkar, p.157.

¹³ Ivantsov, O., Livshits, L., Rozhdestvenskiy, V. 1969. Construction of liquefied natural gas pipelines, Moscow, VNIIGasprom, p.36.

There is experience of transportation of hydrocarbon mixture with high content of ethane fraction in single-phase (liquid) state through pipelines,¹⁴ wide fraction of light hydrocarbons (WFLH)¹⁵ and unstable and stable gas condensate.¹⁶

Many years of experience in operating the Vuktyl - Sosnogorsk Gas Processing Plant (SGPP) main condensate pipeline showed the possibility of transporting unstable condensate over long distances (diameter 530 mm, wall thickness 8.0 mm, steel grade 17GS, pipeline length 186 km). Purovsky GCPP allows to process deethanized (unstable) gas condensate into stable gas condensate and commercial liquefied petroleum gases (LPG). In 2013, the Purovsky Condensate Processing Plant completed the construction of four gas condensate stabilization lines with a total capacity of 6 million tons per year, which increased the capacity of the deethanized condensate processing plant from 5 to 11 million tons per year (Figure 2). Liquid hydrocarbon sales in 2014 amounted to 7.1 million tons compared to 5.4 million tons in 2013.

Today, Russia has a reliable base and technical prerequisites for the widespread use of LNG in the country's economy. A safe technology for handling LNG during liquefaction, storage and refueling of consumers has been developed. However, the transport of LNG via pipelines from storage to transport tanks, from tank to tank in process diagrams is a little-studied problem that requires addressing LNG transport technology by various methods.

The disadvantage of transporting LNG through low temperature pipelines is the need to use special expensive steel grades that allow reliable operation of the pipeline at temperatures up to minus 161°C.

These cryogenic pipelines are executed from expensive and scarce nickel steels, give some, but not sufficient experience to researchers, designers, designers and builders of low-temperature pipelines for conditions of Russia.

A classification of LNG cryogenic pipelines was developed for the purpose of analysis of the liquefied natural gas pipelines created taking into account the technological characteristics of their operation and laying conditions. It is shown in Table 1.

¹⁴ Stolypin, V., Stolypin, E., Volchenko, A., Syrkin, A. 2009. Preparation of hydrocarbon mixture with high content of ethane fraction for transportation. *Oil and gas business*, vol.7, iss.1, pp.94-97.

¹⁵ Rakhmatullin, S. 2012. WFLH Pipeline Safety Issues. *The Chemical Journal*, vol.3, pp.24 - 28.

¹⁶ Korshak, A., Zabaznov, A., Novoselov, V., Matrosov, V., Klyuk, B. 1994. Pipeline transport of unstable gas condensate, Moscow, VNIIOENG, p.204.

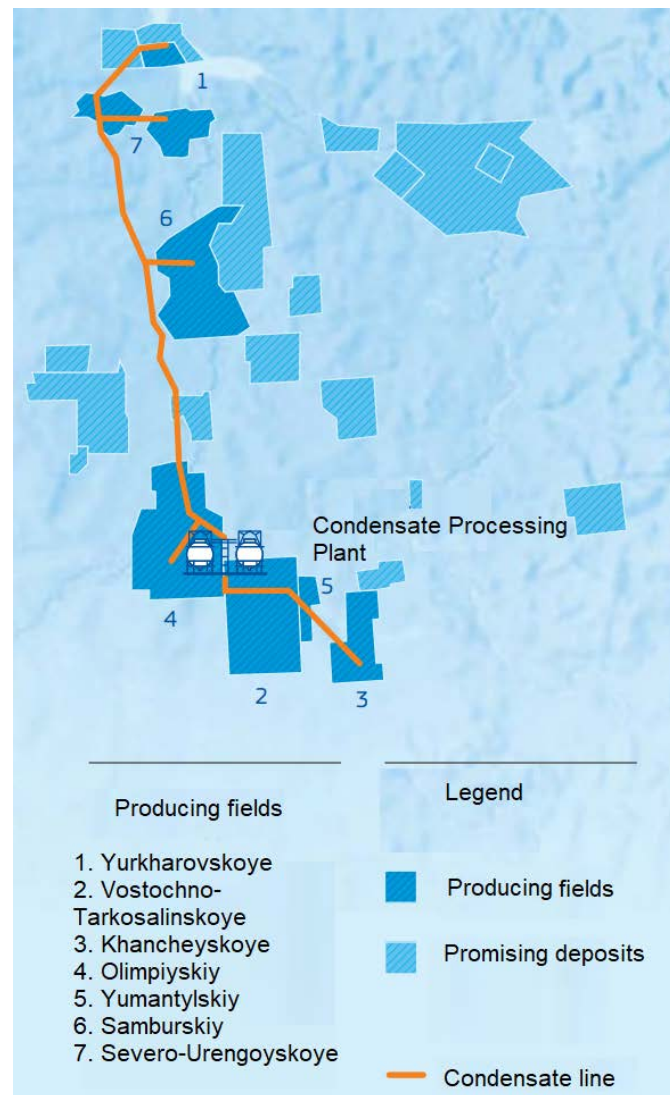
Figure 2: Condensate pipeline route at Purovsky GCPP¹⁷Table 1: Classification of cryogenic pipelines by liquefied gas transfer, gasket types and extent¹⁸

No	Name	Pipeline laying conditions	Diameter, length	Note
1	2	3	4	5
Pressure LNG pipelines				
1	Main	Underground Above-ground On crossings (underwater)	Dn > 100 mm L > 50 km	
2	Subsea main	Underwater Above-water Off-shore	Dn > 100 mm L > 50 km	

¹⁷ http://www.novatek.ru/ru/investors/disclosure/annual_reports/, accessed 03.03.2021

¹⁸ Polozov, A. 2019. High strength of low-temperature heat insulated pipelines. Innovations of science, vol.5, iss.8, pp.26-40.

3	Branch LNG	Underground Above-ground On crossings	Not limited	
4	Process	Underground Above-ground Suspended crossing Technological	Not limited	
5	Subsea process	Underwater Above-water Off-shore Platform	Not limited	
6	Combined	Underground Above-ground On crossings	Not limited	Simultaneous transport of LNG or other liquid products
7	Associated	Underground Above-ground On crossings	Not limited	Via pipeline - LNG Via cryogenic cable – electric power

The American Gas Association draws attention to the complexity of creating cryogenic heat-insulated pipeline structures, reporting that to create trunk pipelines with a sufficiently low negative temperature, there is a material and considerable experience in pumping LNG, but the development of structures is the most difficult and little resolved issue. In this regard, along with the creation of structures, it becomes necessary to create the foundations of the theory of calculating these structures and pipeline systems as a whole.

Existing developments do not fully cover all the issues necessary for the design and construction of low-temperature main pipelines pumping liquefied hydrocarbon mixtures. The features and mechanisms of transport of liquefied hydrocarbon gases through main pipelines over long distances have not been sufficiently studied.

The design of liquefied gas pipelines currently lacks a unified approach to many critical issues. In hydraulic and thermal calculations, different dependencies are used, which leads to large differences in the obtained data after calculations. The issue of determining temperature variation with a sufficient degree of accuracy along the pipeline route during their cooling is little understood. In this regard, it is necessary to develop new technical solutions that make it possible to increase the efficiency of transportation of liquefied hydrocarbons of gas condensate deposits of the Far North through low-temperature main pipelines.

2.2 Provision of LNG transport

2.2.1 Internal LNG transportation

Since the share of gas transported in the liquid state is constantly growing, this contributes to the development of LNG transportation technology not only by sea tankers, but also the introduction of LNG distribution systems to end users by land. A virtual pipeline is a project to regularly transport LNG by land between two points, dispensing and receiving.

This technology requires optimal equipment selection, as well as economic optimization between real and virtual pipeline options.

The LNG dispensing point is usually a large LNG storage facility. As repositories, the onshore receiving terminal of large tankers or other repositories that are supplied with LNG from their other sources may act. A LNG receiving point is a large industrial plant that requires a large amount of gas for production technology or heating. Also, such points may be local storage, from which distribution occurs by small cryogenic pipelines or small cryogenic tanks to small consumers, including residential buildings. The receiving locations may be satellite stations where LNG evaporates for local needs.

For the implementation of such a project, the installation of a delivery point is required. To do this, it is necessary to have a large tank in which LNG is stored at close to atmospheric pressure at low temperatures.

Typical LNG vehicles are car trailers or heat insulated tank containers. Such transport is very advantageous as a road transport from the place of issue to the place of reception of LNG. A huge advantage of tank containers is the ability to be transported by a combined method to remote places of reception without pumping LNG - car road, railway, river, sea, ocean. The container tank comprises two main elements, a tank and a frame, which comply with international standard ISO 1496/3. An image of the LNG container tank is shown in Figure 3. Such cryogenic tank containers with a volume of 20 m³ are produced by «Chart Ferox».



Figure 3: Tank-container for LNG transportation¹⁹

The container tank comprises two main elements, a tank and a frame, which comply with international standard ISO 1496/3. Such containers are very practical and can be used for the transport of LNG by almost any mode of transport with the possibility of its change.

¹⁹ <https://uralrezerv.com/emkosti-dlya-hraneniya-i-transportirovki/tank-kontejnery>, accessed 01.03,2021

One of the most important issues in the implementation of this project is its economic feasibility. The advantage of virtual pipelines is the short construction time of the project and the ability to move equipment to another field. A typical virtual pipeline usage scheme is shown in Figure 4.

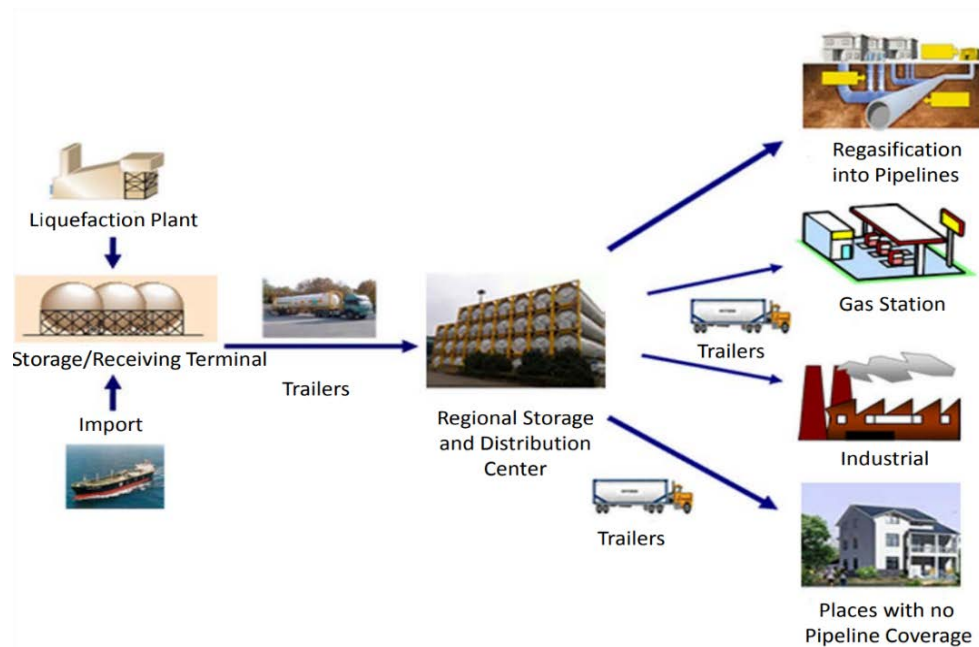

Figure 4: Typical Virtual Pipeline Usage Scheme²⁰

At the point of delivery, the gas is in a liquefied state. For its transportation by a traditional gas pipeline, it must be regasified and pumped a predetermined distance using intermediate compressor stations. In the case of virtual, LNG is immediately pumped to cryogenic containers and transported to the receiving point where the tank and evaporator are to be installed. Such a transportation scheme is an economically advantageous alternative to gas pipelines for transporting LNG over short distances and hard to reach locations.

It is advisable to use the virtual pipeline project to transport associated petroleum gas. So, Edge LNG supplies high-quality LNG obtained by converting emitted and burned natural gas. Edge LNG was the first to present the project in the United States. If there is no need for pipelines, this project is an advantageous alternative to burning or removing associated gas from oil production.²¹

The «Edge LNG» Virtual Pipeline operates by deploying transportable Cryobox LNG production and liquefaction equipment from natural gas wells and delivering LNG directly to the consumer (Figure 5). «Edge LNG» Cryobox units are installed on a standard 40 ft tractor trailer and are designed for quick and easy connection and disconnection from wells

²⁰ <https://www.international-bc-online.org/wp-content/uploads/2018/02/7.-XIE-RUS.pdf>, accessed 15.03.2021

²¹ <https://gas-solutions.ru/news/virtualnyj-spg-truboprovod/>, accessed 18.03.2021

with raw gas.²² This system operates from the same gas, which eliminates the need to connect to the power supply.

This is a huge income for oil producers who are forced to burn or produce associated gas. This solution does not require large capital and operational costs.

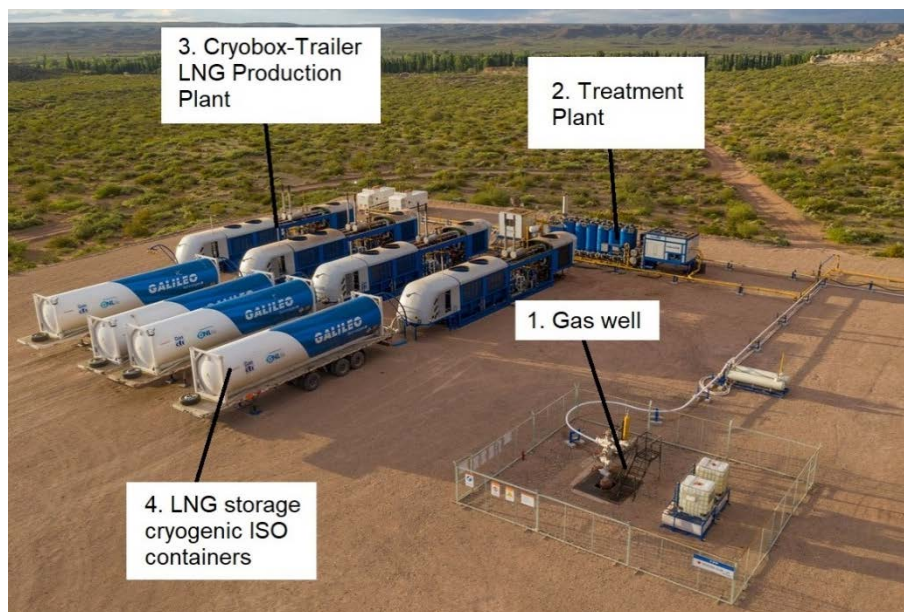

Figure 5: LNG Virtual Pipeline²³

2.2.2 Transportation of LNG via process pipelines to meet domestic production needs

LNG is dispensed to the consumer in transport tanks at LNG production, storage and dispensing complexes. The LNG complex includes a natural gas liquefaction plant, a storage, discharge - filling and evaporation (gasification) system of LNG, as well as a filling site for tank vehicles. The filling area contains flooding devices with a platform for tanker trucks. LNG transport from cryogenic storage tanks to transport tanks can be performed by the following methods:²⁴

- due to the difference in levels (gravitational method);
- by pressure transfer with an inert gas with a lower boiling point (nitrogen);
- by pressurizing the LNG vapors produced in the evaporator;
- by means of pumps of various design (centrifugal, piston, submersible).

²² Ivantsov, O. 1968. Transport and storage of liquefied gas in France. Moscow: VNIOENG, p.12-14.

²³ <https://gastopowerjournal.com/technologyinnovation/item/10522-edge-lng-to-use-mobile-liquefaction-units-at-marcellus-shale>, accessed 18.03.2021

²⁴ PB 08-342-00. Safety Rules for Production, Storage and Delivery of Liquefied Natural Gas at Gas Distribution Stations of Main Gas Pipelines and Automobile Gas Filling Compressor Stations

The evaporator gas transfer method is widely used when delivering LNG, LPG, liquid nitrogen, oxygen from transport tanks.²⁵ However, this is not possible for large storage facilities, since at high hydrostatic pressure created by liquid in the storage facility, a slight increase in overpressure causes critical stresses in the walls of the storage facility.²⁶ The same limitation applies to the lower boiling inert gas transfer method.

For large warehouses, it is more advisable to use self-suction pumps, in addition, the filling time of transport tanks is reduced. However, in order to transfer cryogenic liquid, it is necessary to cool the pumps immediately before starting their operation. This creates some difficulties in the operation of the system, so the use of pumps is limited to cases when it is necessary to create a significant pressure at the inlet to the pipeline.²⁷

Centrifugal and piston pumps are used on an industrial scale to transfer cryogenic liquids. Piston pumps for liquid oxygen and nitrogen make it possible to create a high pressure of up to 1000 atm in the supply channel at its low flow rates.²⁸

Centrifugal pumps are most suitable for LNG pumping, which are able to transfer large amounts of liquid (tens of cubic meters per hour) at relatively low pressures (from 2 to 20 atm). However, they are very sensitive to the presence of gas in the pumped liquid, and at a gas content of more than 2%, their operation is disrupted and the elements of the pump impeller are destroyed.²⁹

In some cases, submersible pumps are used when emptying LNG storage facilities and unloading methane tankers for LNG transfer. They shall be suspended from lifting pipes and lowered into LNG to such a depth that the pump is below the dynamic level of LNG in the tank by not less than 1.5 m.

The use of pumps is related to the consumption of electricity, which, given the flammability of natural gas, can cause explosion and fire hazard situations. Therefore, it is better to transport LNG from a storage facility located in an elevated area to a downstream tank by gravity. The gravitational method is widely used at oil depots when draining and filling railway tanks in view of the simplicity of design, the absence of complex mechanical equipment, the

²⁵ Ilyinskiy, A. 1976. Transport and storage of industrial liquefied gases. Moscow: Chemistry.

²⁶ Semerikov, A. Patent RF №2715533. Device for liquefied gas discharge from low pressure tanks.

²⁷ Filin, N., Bulanov, A. 1985. Liquid cryogenic systems. Mechanical engineering, vol.4, pp.245-249.

²⁸ Fastovskiy, V., Petrovskiy, Y. Rovenskiy, A. 1967. Cryogenic engineering. Moscow: Energiya.

²⁹ Korshak, A., Shammazov, A. 2002. Fundamentals of oil and gas business. Ufa:DesignPolygrafService, second edition.

readiness of the circuit for operation at any time, regardless of the presence of foreign energy sources.³⁰

2.3 Features of cryogenic fluids transport

LNG is transported through main pipelines at low temperatures (about -120... -100°C), which leads to the use of effective heat insulation of pipelines to avoid intense heat inflows. The presence of even the most advanced thermal insulation does not exclude the supply of heat to the LNG and, therefore, its heating and the formation of a vapor phase. In order to transport LNG in a single phase state, the pressure in any section of the pipeline shall be higher than the saturated vapour pressure corresponding to that temperature (or the LNG temperature shall be lower than the saturation temperature at that pressure). Efficient transportation of LNG can be achieved with the correct selection of parameters: pressure P , temperature T , which will prevent the formation of two-phase flow in the pipeline.

The most important period is the commissioning of the liquefied gas pipeline. Prior to start-up, it is pre-cooled, for which purpose liquefied gas supplied to the pipeline with operating temperature is usually used. Liquefied gas moves through the pipeline, evaporates and cools the walls of the pipeline. The vapour phase of the liquefied gas must be discharged from the pipeline at certain intervals to provide the required inlet gas flow rate for cooling the pipeline and to reduce the vapour phase pressure at the beginning of vaporization of the liquefied gas. During operation, the maximum speed of liquefied gas in the pipeline shall not exceed 4.5 m/s, and the coefficient of hydraulic resistance shall be assumed to be 0.014 for all pipelines.³¹ In addition to damage to liquefied gas pipelines associated with crack formation, depressurization of the pipeline at points of connection, usually flange, is a great danger during operation. These accidents usually occur during the initial period of pipeline operation and occur due to incorrect material selection of sealing gaskets installed between flanges.

The most important technological condition for the transport of liquefied natural and hydrocarbon gases is the constant maintenance of pressure and temperature values in the pipeline, which will prevent the boiling of pumped cryogenic liquids. Violation of this condition can cause phase transition or formation of hydrate plugs if moisture was present in the pipeline.³² For this reason, it is fair to show to the cryogenic LNG pipeline the complete tightness of the connections, valves, drying of the pipeline before starting the transfer of the liquefied product.

³⁰ Preobrazhenskiy, N. 1975. Liquefied petroleum gases. Moscow: Nedra.

³¹ Bleyher, E., Vladimirov, A., Ivantsov, O., Polskiy, S. 1977. Liquefied natural gas pipeline transport. Moscow, VNIIGasprom, p.63.

³² Zhmakin, V. 2019. Development of methods and technical solutions for transportation of liquefied natural gas through low-pressure pipelines. Cryogenic technologies, vol.6, iss.20, pp.85-92.

Phase diagrams and critical parameters of gas and gas condensate mixtures in different ratios make it possible to determine the required composition for transportation in a single-phase liquid state in the specified temperature and pressure range, to predict the phase behavior of liquefied hydrocarbons at different temperatures and pressures for subsequent transportation through a low-temperature pipeline. When transporting liquefied natural gas, it is necessary to achieve the necessary parameters, which must be continuously maintained throughout the delivery period to the consumer. It is known that the LNG temperature should be -160°C (under normal conditions) (Figure 6).

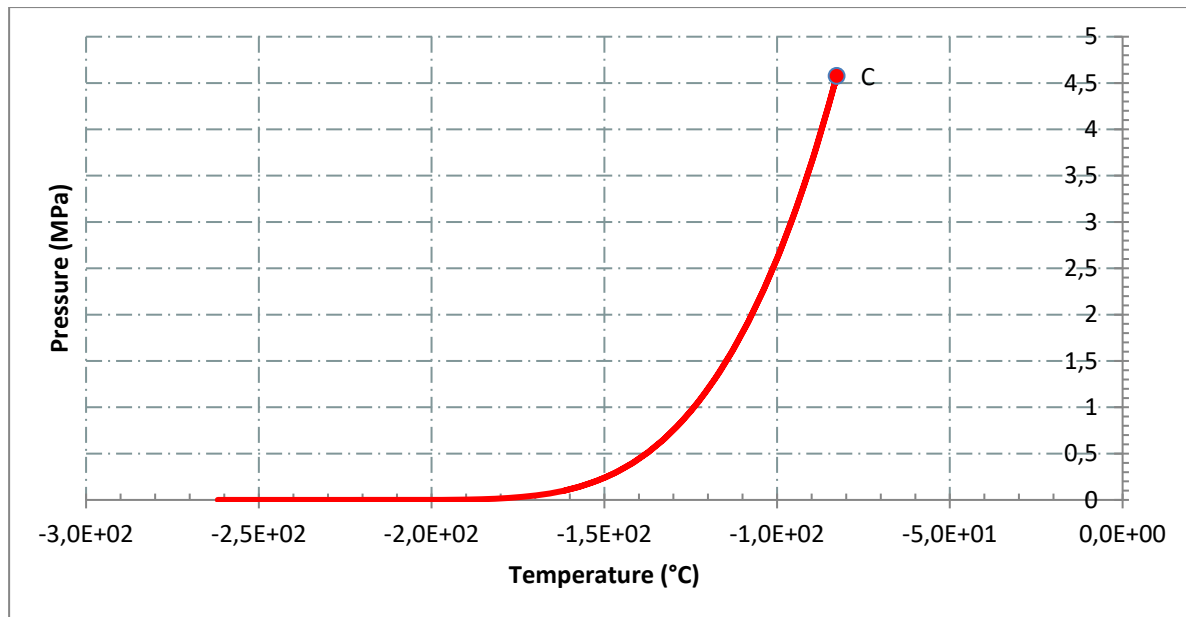

Figure 6: Methane Phase State Diagram

A distinctive feature of transporting LNG through pipelines is the possibility of a two-phase flow due to evaporation of a part of the liquid from heat influx from the environment. This results in a significant decrease in the capacity of the pipeline and increases its hydraulic resistance.³³

A separate challenge is the initial cooling and filling of the "warm" pipeline, which precedes the stationary operation of the LNG pipeline. The supercooled LNG begins to enter the pipeline at ambient temperature, with all liquid rapidly evaporating and the pipeline filled with steam. The pressure in the vapor space increases quite rapidly, so much that it can balance or exceed the pressure at the inlet, which can lead to a change in the direction of movement of the liquid. As the initial section of the pipeline cools, the front of the liquid moves towards the outlet and gradually the entire pipeline acquires an operating temperature close to the temperature of the transferred liquid.³⁴

³³ Chisholm, D. 1986. Fundamentals of oil and gas business. Moscow: Nedra.

³⁴ Fastovskiy, V., Petrovskiy, Y. Rovenskiy, A. 1967. Cryogenic engineering.

After the cooling step, LNG can be transported via pipeline in a single phase state or with partial evaporation (two phase flow). During operation of cryogenic pipelines, LNG transportation parameters are selected so as to prevent formation of a vapor phase in the pipeline. The formation of a vapor phase even in an adiabatic stream cannot be avoided if the LNG inlet temperature exceeds the saturation temperature at its outlet.

In horizontal and slightly inclined pipelines at low flow rates, LNG transportation is carried out in stratified mode (Figure 7): the liquid phase of LNG is completely concentrated at the bottom of the pipeline, and the steam phase is concentrated at the top of it.³⁵

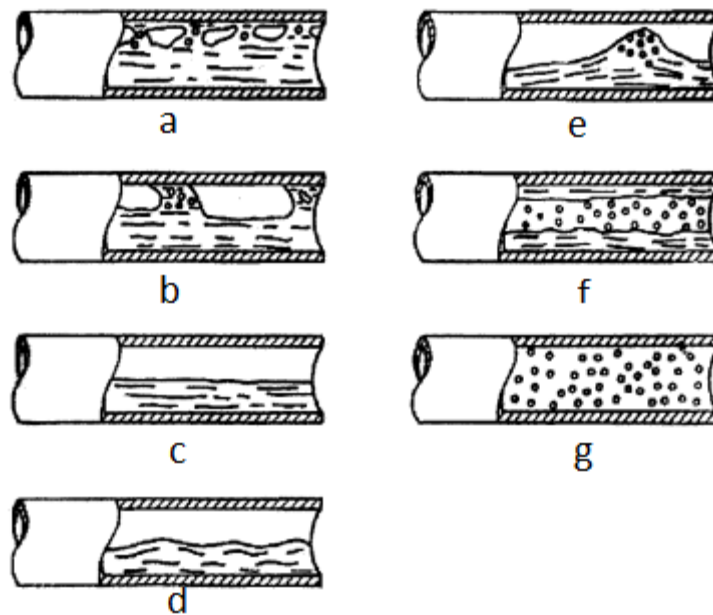

Figure 7: LNG flow modes in horizontal pipelines³⁶

Where a is the bubble regime, b – plug, c – stratified, d- wavy, e – shell, f – ring, g – emulsion.

Stratified smooth and stratified wavy flow modes are distinguished. At relatively low vapor phase rates, phase delamination occurs. The steam phase occupies the top of the pipeline. As the velocity of the vapor phase increases, waves occur on the surface of the liquid phase layer, the ridges of which do not overlap the section of the pipe. These modes can only exist in horizontal pipelines.

The efficiency of LNG transportation largely depends on the specifics of cryogenic pipeline structures and their thermal insulation.

³⁵ Kutepov, A., Sterman, L., Styushin, P. 1986. Hydrodynamics and heat

³⁶ Voronov, V., Martynenko, Y. 2017. The comparative analysis of single-phase regimes of natural gas transportation by pipeline system. International science journal, vol.4, iss.58, pp.28-34.

2.4 Design features of cryogenic LNG pipelines

2.4.1 Cryogenic LNG Pipeline Designs

Liquefied natural gas pipelines belong to a special class of gas pipeline systems. This is due to the transport of gas through the pipeline under cryogenic and primarily in northern extreme conditions.

In the northern regions, especially in the tundra, underground LNG pipelines are the most promising, since, firstly, many thousands of herds of reindeer during the above-ground laying of the pipeline are not able to pass its string even with completed passages. The above-ground structures are alien to them, so they are afraid and do not even go to the aisles. Secondly, the above-ground LNG pipeline is about 40% more expensive than the underground by using movable and fixed supports and at least 40%) serves less due to high damage.

Above-ground laying of LNG pipelines on supports providing four degrees of freedom of transverse movement, in the absence of contact - movement-friction with external elements does not cause concerns in terms of strength and reliability of their structures. Use of support for above ground gasket is given in Figure 8. During installation of above-ground LNG pipelines, the integrity of their components is ensured by construction measures. At the same time, the underground heat insulated LNG pipeline, with large dynamic axial movements and transverse movements, experiences enormous resistance from the surrounding soil and the occurrence of large, often unacceptable stresses in its design. At the same time, thermal insulation, being low-density, and, therefore, low-strength, provides high indicators for reducing heat and mass transfer. However, in terms of structural strength, low density thermal insulation is not acceptable. Therefore, it is necessary to create a thermal insulation coating structure that satisfies the requirements for both thermal conductivity and strength. On the other hand, it is necessary to create the foundations of the calculation method, allowing to carry out a pre-design analysis of the strength and reliability of the pipeline system with volumetric thermal insulation in general.

In addition to the need to develop thermal insulation structures, it is required to create systems for compensating, supporting and fixing low-temperature pipelines. These structures used for conventional gas pipelines, heating networks and special pipelines are ineffective or not acceptable at all due to the specifics of the operation of the cryogenic LNG pipeline.

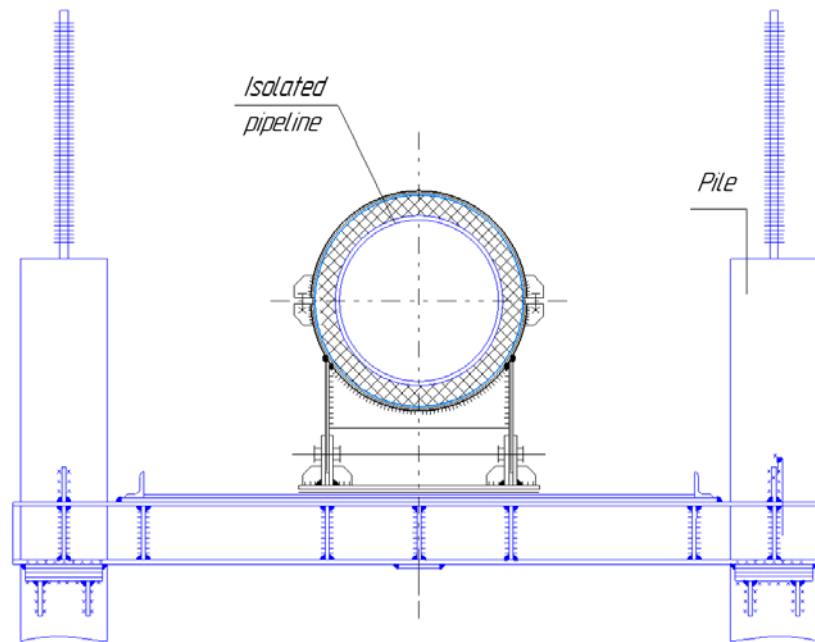

Figure 8: Support for above ground laying of cryogenic LNG pipeline

The use of special cryogenic piping structures allows to reduce heat inflows, providing conditions for the transportation of LNG in a single-phase state to remote consumers. Industrial structures of cryogenic pipelines are based on evacuated types of thermal insulation: vacuum-powder, layered-vacuum and sometimes purely vacuum³⁷, as well as with bulk, porous and fibrous thermal insulation. Domestic and foreign experts recommend foamed materials as heat insulation of LNG pipelines: polyurethane foam, polystyrene foam, cork, epoxy foam, foam glass. These materials have a porous structure formed by closed type cells. When gas is pumped out of these materials, their thermal conductivity is significantly reduced. In addition, this type of insulation is not permeable to water vapors, and the presence of high-quality vapor insulation allows to further reduce the moisture content of the thermal insulation by several times.

On existing low-temperature pipelines, the heat intensity to the pipeline product from outside, according to VNIIST (All-Union Research Institute for the Construction and Operation of Pipelines), even with some types of thermal insulation, reaches 5.8-23.3 W/m². In order to provide the least heat input to the product, the bulk thermal insulation of the shell must have a thickness often comparable to the diameter of the pipeline, and this is not provided for by existing methods for calculating the strength of cryogenic pipelines during channel-free laying. At the same time, volumetric insulation is more effective than it is lighter, but the lighter it is, the less durable it is. And insufficient thermal insulation does not ensure the integrity and operational reliability of the pipeline system design.

³⁷ Gorbatskih, Y. 2000. Use of cryogenic fuels in prospective aircraft. Technical facilities of cryogenic infrastructure of natural gas liquefaction complexes, vol.5, pp.44-48.

Experimental studies carried out in our country in laboratory conditions and in pilot-industrial sections of pipelines pumping cooled nitrogen with a temperature of -145°C showed that polystyrene foam, polyurethane foam and other foams best meet the requirements for low-temperature insulation of the pipeline.³⁸ The use of foams is cost effective, since it allows to reduce the thickness of thermal insulation by about 2 times compared to insulation from mineral fibers.³⁹ However, during underground laying due to the difficulty of installing and operating pipelines, it is more advisable to use thermal insulation of the volumetric type. In addition, a wide variety of pumping products (liquefied gas, helium, etc.) through the pipeline, as well as the presence of complex geological areas on the routes, do not always allow the use of volumetric thermal insulation in the pipeline design.

Design of LNG pipelines with thermal insulation from foams was proposed: in straight sections of underground pipeline - sliding structure (Figure 9), and in sections of pipeline outlet from soil, in compensator areas and at route angles - structure with rigid foam segments (Figure 10).

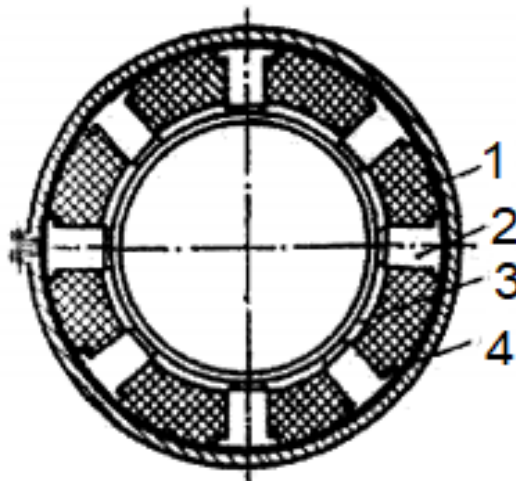

Figure 9: Sliding structure of heat insulated pipe coating⁴⁰

Where 1 - is thermal insulation, 2 – sliding elements, 3 – pipeline, 4 – casing, 5 – fixing belt.

³⁸ Sharygin, A., Polozov, A., Sharygin, V. 1983. Thermal insulation strength under radial compression conditions. Oil and gas construction in the Far North. Moscow:VNIIST, pp.3-9.

³⁹ Ilyinskiy, A. 1976. Transport and storage of industrial liquefied gases. Moscow: Chemistry.

⁴⁰ Polozov, A. 1988. Refrigerated and liquefied natural gas main pipelines. Syktyvkar, p.157.

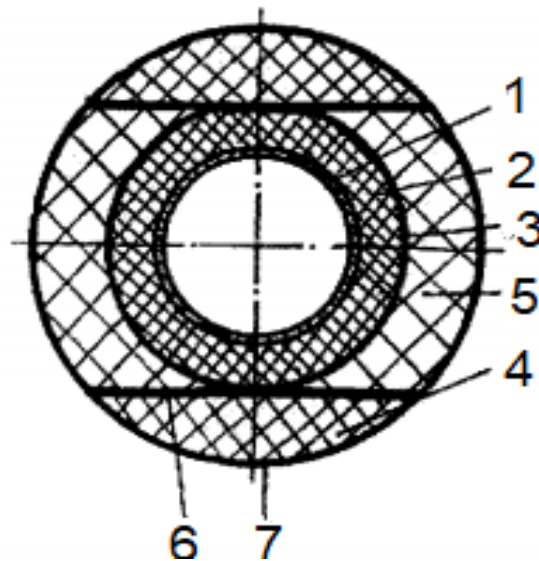

Figure 10: Heat insulation structure for turning⁴¹

Where 1 is the pipe, 2 – inner layer of heat insulation, 3 is a vapor insulating layer, 4 – rigid segment, 5 – soft segments, 6 – antifriction layer, 7 – outer casing.

High reliability of the pipeline as a whole in terms of strength can be achieved by using a vacuum pipeline with a technical vacuum depth of $10 \cdot 10^{-2}$ Pa in such sections.⁴² But this requires periodic vacuum recovery, which is possible on a limited number of heavy sections of the pipeline route. It is possible to use a vacuum pipe structure providing vacuum in the annulus by injecting a working product stream.⁴³

The large length of cryogenic LNG pipelines, usually associated with the intersection of different soils, water and other barriers, requires the use of different structures on one pipe line. A wide variety of characteristics of transported working products (by temperature) having various purposes (long-distance transportation, storage, regasification) requires the use of various options for the design of the pipeline.

The creation of efficient LNG piping structures cannot be realized without the use of efficient but expensive pipe steels and welding materials.

Figure 11 shows the main structural elements of the cryogenic LNG pipeline. Elements contributing to reduction of conductive thermal conductivity are supports and cone elements between internal pipeline and casing. A natural solution to the problem of reducing heat gain

⁴¹ Polozov, A. 1988. Refrigerated and liquefied natural gas main pipelines. Syktyvkar, p.157.

⁴² Ilyinskiy, A. 1976. Transport and storage of industrial liquefied gases. Moscow: Chemistry.

⁴³ Polozov, A. Patent RF №2551005. Vacuum insulated piping.

is to reduce the thickness and increase the length of the cones, as well as to use non-metallic materials with low thermal conductivity for internal supports.

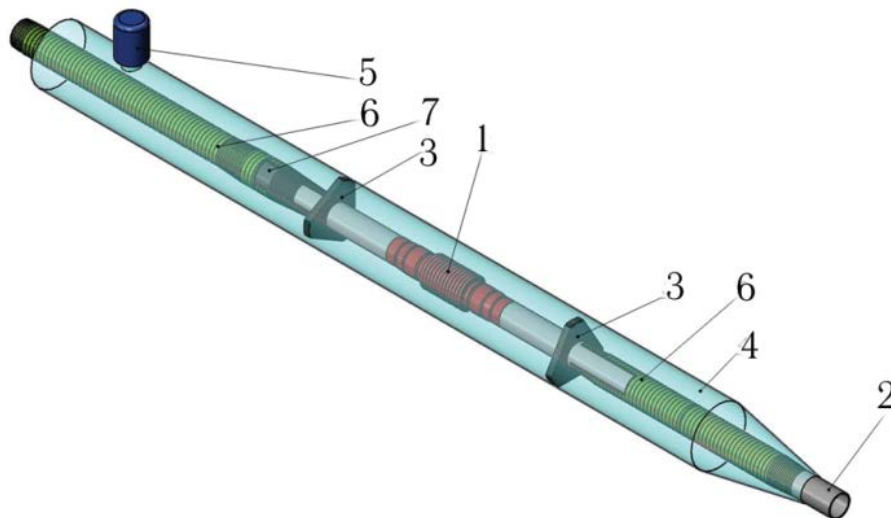

Figure 11: LNG Cryogenic Piping Section Arrangement⁴⁴

Where 1 is the compensator, 2 – internal pipe, 3 – support, 4 – vacuum port, 6 – heat insulation, 7 – adsorbent.

The pipeline with high vacuum insulation at the points of connection has special vacuum casings. The vacuum in the insulation space is maintained by means of adsorbents - activated carbon or silica gel, which are placed in special "baskets" attached to the inner pipe; the cold surface of this pipe increases the adsorption capacity of the absorbers.

Pipelines with vacuum-powder insulation are less convenient to use, since during vibration it is possible to shrink the powder, which reduces the efficiency of insulation. Multi-layer insulation pipelines reduce heat inflow to liquid. However, this increases the duration of the non-stationary mode and increases the losses for pre-cooling of the pipeline.⁴⁵

The Russian industry produces flexible hoses with an internal diameter of 40, 70 and 100 mm. The "Mouth" nuts, which are equipped with hoses, ensure their quick and reliable connection to the tanks. Foreign companies produce flexible cryogenic pipelines with a flow section of 12 to 87 mm.⁴⁶ The schematic design of such a pipeline is shown in Figure 12. The length of such pipelines is 300-600 m. Pipes 1 and 2 are made of corrugated copper. Spacer 3 is a polyethylene strip wound spirally on an inner tube. The preliminary vacuum in the insulating space is about 10⁻³ Pa (about 10⁻⁵ mm Hg). With an internal pipeline diameter of

⁴⁴ <http://cryoservice.ru/wp-content/uploads/2015/02/truboprovody-statiya.pdf>, accessed 04.04.2021

⁴⁵ Ilyinskiy, A. 1976. Transport and storage of industrial liquefied gases. Moscow: Chemistry.

⁴⁶ Malkov, M. 1973. Manual of Physical and Technical Fundamentals of Cryogenics. Energy, vol. 5, pp.89-93.

32 mm, heat inflows are about 1.3 W/m. The shell 4 is filled with a strong insulating material, polyvinyl chloride.

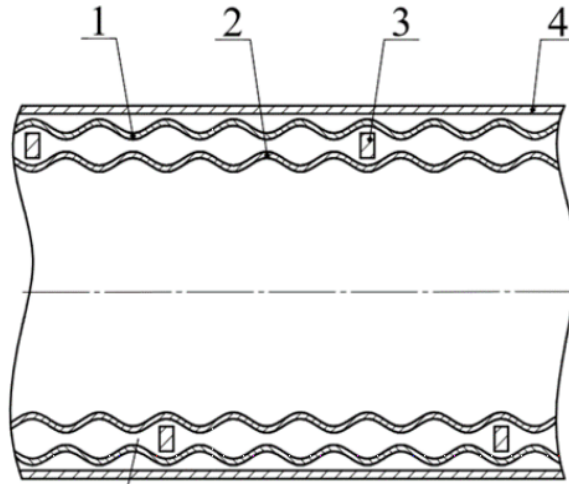

Figure 12: Flexible cryogenic piping diagram⁴⁷

As structural materials of the inner pipe, stainless steel of type 12Cr18N10T and sometimes invar 36NCr is used. Aluminum and its alloys, copper and copper alloys are also used. The mechanical properties of these materials at low temperatures are improved. The outer casing is made of stainless or carbon steel.⁴⁸

It is necessary to develop new technical solutions that improve the efficiency of transportation of LNG and other cryogenic liquids through pipelines. From patent sources there is known pipeline,⁴⁹ which provides transportation of cryogenic liquid from one reservoir to another due to difference of levels (Figure 13). Prevention of gas bubbles accumulation in vertical pipeline is achieved by removal of gas bubbles through holes into annular space communicated with atmosphere. However, the proposed technical solution has not been tested in production conditions, and theoretical and experimental studies have not been carried out to remove the vapor phase from the pipeline, in addition, the installation of cones in the inner pipe of this pipeline is technically difficult to carry out, the development of special equipment for the serial production of this pipeline design is required.

⁴⁷ Malkov, M. 1973. Manual of Physical and Technical Fundamentals of Cryogenics. Energy, vol. 5, pp.89-93.

⁴⁸ Fastovskiy, V., Petrovskiy, Y. Rovenskiy, A. 1967. Cryogenic engineering. Moscow:

⁴⁹ Semerikov, A., Polozov, A. Patent RF №2731276. Cryogenic Fluid Drain

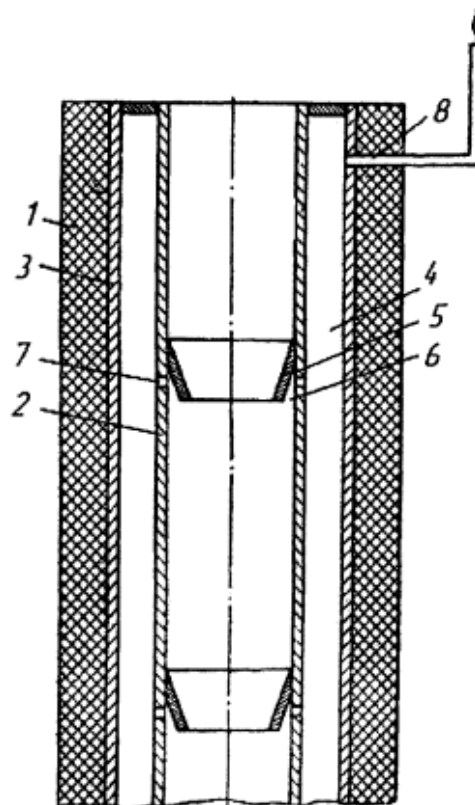

Figure 13: Cryogenic Fluid Drain Piping⁵⁰

Where 1 is the heat insulation from porous and fibrous materials, 2,3 – two coaxially located pipes, 4 – annular space, 5 – flow narrowing elements, 6 – cavities, 7 – holes, 8 – gas outlet.

High requirements apply to heat insulation coatings of low-temperature pipelines laid on the seabed and on heavy water barriers and swamps. The use of thermal insulation materials of the volumetric type in this case requires the use of heat insulation capsules⁵¹, which are sealed closed annular vessels with a double metal shell (a space that is filled with foamed, fibrous or backfill heat insulation), constituting a single pipeline.

Capsules are welded to each other by welding at joints or are connected by special couplings. The pipeline design is shown in Figure 14. It has oblique joints, reduces heat inflows to the low-temperature product to acceptable values (not more than 3%). The capsule structure also has an "oblique joint" that drastically reduces through them the heat inflows to the transported product. On one side it is welded with annular weld 3, on the other side it has bellows 4 and liquid seal 5 to change the total length of working pipeline 6. This design was proposed by Kraiser Brencar, but such a pipeline, due to the bulkiness, presence of bellows

⁵⁰ Semerikov, A., Polozov, A. Patent RF №2731276. Cryogenic Fluid Drain

⁵¹ Latypov, M., Polozov, A. Slepokurov, E 1993. Patent RF №3559816. Method of laying underground pipe string of pipe type in pipe.

compensators, liquid sealing and high cost of manufacture, is acceptable in rare cases and only as marine SPG wires.

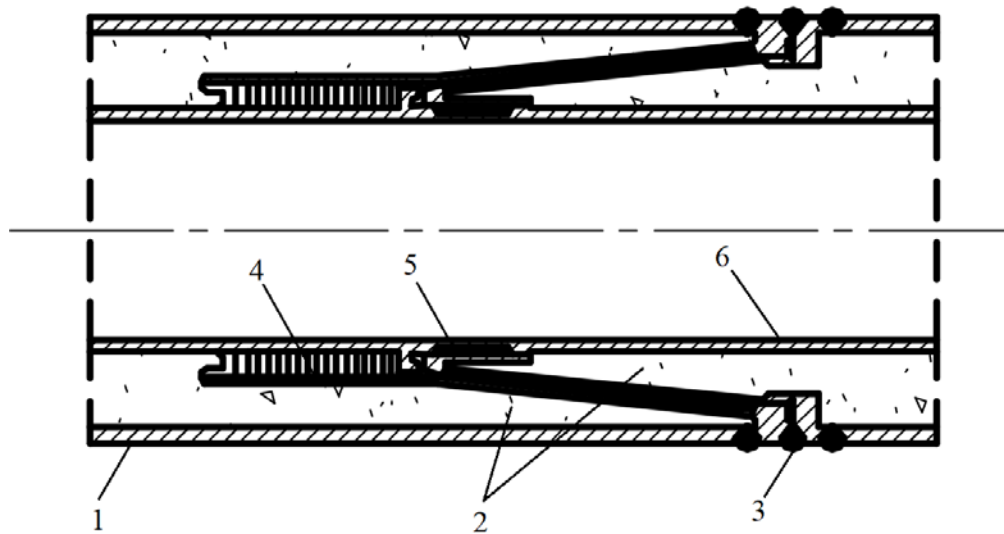

Figure 14: Capsule design⁵²

Where 1 is the metal case, 2 – heat insulation capsule, 3 – weld seam, 4 – bellows compensator, 5 – liquid seal, 6 – product pipeline.

When using these structures in critical areas, it is advisable to supply dried air to the heat insulation volume (in the absorber or adsorber) in order to prevent water penetration in a vapor-like state and prevent soaking of the heat insulation.

When using these structures in critical areas, it is advisable to supply dried air to the heat insulation volume (in the absorber or adsorber) in order to prevent water penetration in a vapor-like state and prevent soaking of the heat insulation.

Another real-world cryogenic pipeline design was proposed in another patent.⁵³ The cryogenic pipeline contains a pipeline itself, enclosing a casing with formation of a heat-insulating cavity and an elastic adsorbent and heat-insulating material placed on the external surface, and is additionally equipped with an elastic gas-permeable material tightly enclosing the adsorbent, and the heat-insulating material is placed above the gas-impermeable material.

Cryogenic pipeline (Figure 15) contains pipeline (1), enveloping it with formation of heat-insulating cavity (2) casing (3) and elastic adsorbent (4) and heat-insulating material (5)

⁵² Latypov, M., Polozov, A. Slepokurov, E 1993. Patent RF №3559816. Method of laying underground pipe string of pipe type in pipe.

⁵³ <http://www.freepatent.ru/patents/2239746>, assesses 02.04.2021

located on external surface of pipeline (1) proper. The conduit 1 itself is further provided with an elastic gas-permeable material 6 which densely encloses the adsorbent 4, and the heat-insulating material 5 is placed above the gas-permeable material 6, which may be, for example, either in the form of a net applied to the surface of the elastic adsorbent 4 or in the form of a glass tape spirally applied without gaps to the surface of the elastic adsorbent 4. The pipeline itself is additionally equipped with a distancing spacer 7 placed between gas-permeable and heat-insulating materials 6 and 5, wherein the spacer is made either in the form of a wire spiral, the ends of which are brought out from under the heat-insulating material 5, or in the form of a set of rods parallel to the axis of the pipeline proper 1, wherein the ends of the rods are brought out from under the heat-insulating material 5.

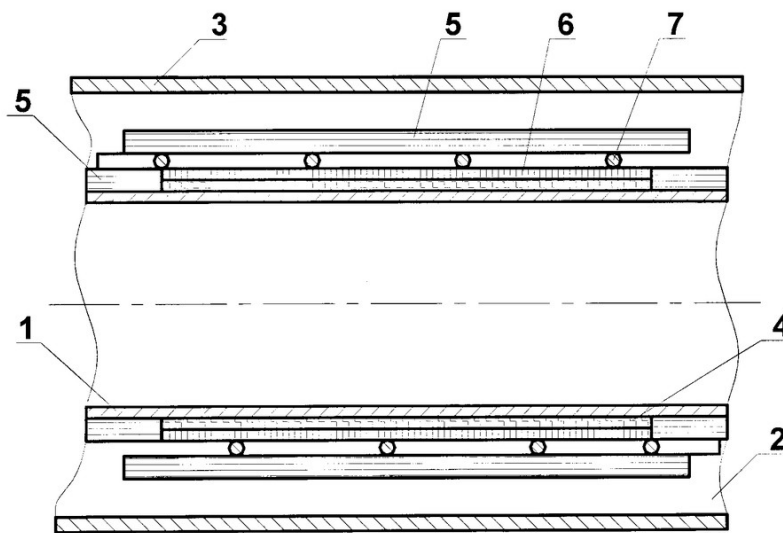

Figure 15: Longitudinal section of cryogenic pipeline⁵⁴

The proposed cryogenic pipeline design works as follows. Previously, the heat insulation cavity 2 is evacuated and the residual pressure in it is about $1 \cdot 10^{-1}$ mm Hg. Liquid cryoprodukt is then supplied via line 1 itself. When the pipe 1 itself is cooled, the elastic adsorbent 4 is cooled, which intensively absorbs the gas contained in the heat insulation cavity 2. As a result, the residual pressure in the heat insulation cavity 2 decreases to a level of less than $1 \cdot 10^{-4}$ mm Hg, which provides minimal heat inflows to the pipeline itself from the side of the casing 3. The process of reducing the residual pressure in the heat insulation cavity proceeds the faster, the faster the adsorbent is cooled. The elastic gas permeable material, which tightly encloses the elastic adsorbent, provides reliable thermal contact of the latter with the surface of the pipeline itself, and therefore cooling intensity. Remote spacer provides guaranteed clearance between gas-permeable and heat-insulating materials, besides, this gap has outlets into heat-insulating cavity, thus reliable access of gas from cavity to adsorbent is achieved.

⁵⁴ <http://www.freepatent.ru/patents/2239746>, assesses 02.04.2021

The design of the various spacers for cryogenic piping centering the inner pipe with respect to the outer pipe is shown in Figure 16. The material of the spacers is most often fluoroplastic-4, since it, along with a small coefficient of thermal conductivity (about $3 \cdot 10^{-1}$ W/(m·K)), has a small coefficient of gas release in vacuum.

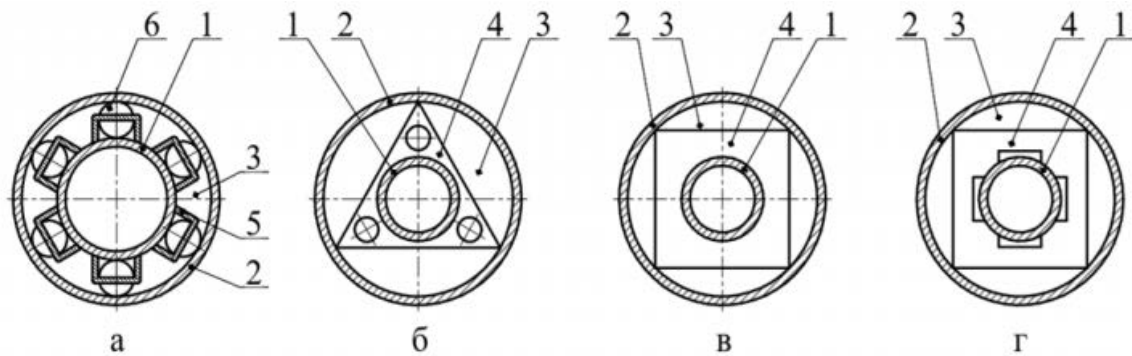

Figure 16: Structural diagrams of inner pipe spacers relative to the casing

Where a is the six-ball guide, б – triangular, в, д – square, 1 – inner pipe, 2 – external pipe, 3 – vacuum cavity, 4 – spacer, 5 – holder, 6 – ceramic or stainless steel ball.

Compensation for temperature stresses is provided by the use of bellows, and in some cases by installing U-shaped or lyre-shaped compensators by bending the pipeline itself. The first method is preferable because it reduces metal consumption and simplifies the installation of the pipeline. The design of the bellows is shown in Figure 17. The corrugated surface gives them sufficient rigidity with high mobility in the axial direction.

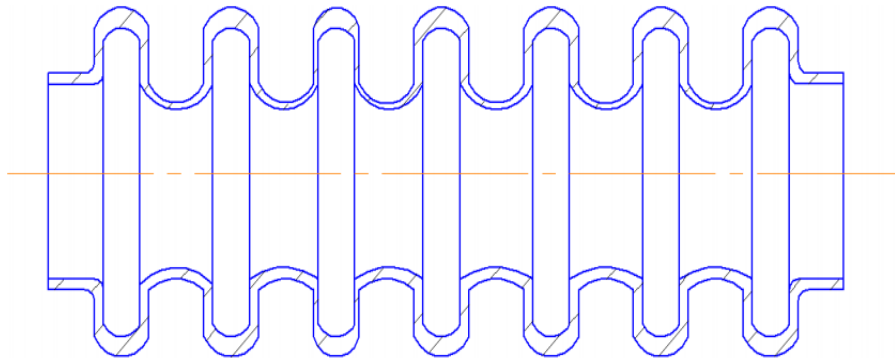

Figure 17: Expansion bellows⁵⁵

The use of bellows for connecting long sections allows you to make detachable structures (Figure 18). Typically, the length of each section is 12 m. The vacuum space of each section contains an adsorbent to maintain a sufficiently high vacuum under operating conditions.

⁵⁵ Kaganer, M. 1966. Thermal insulation in low temperature equipment. Mechanical engineering, vol.12, pp.42-56.

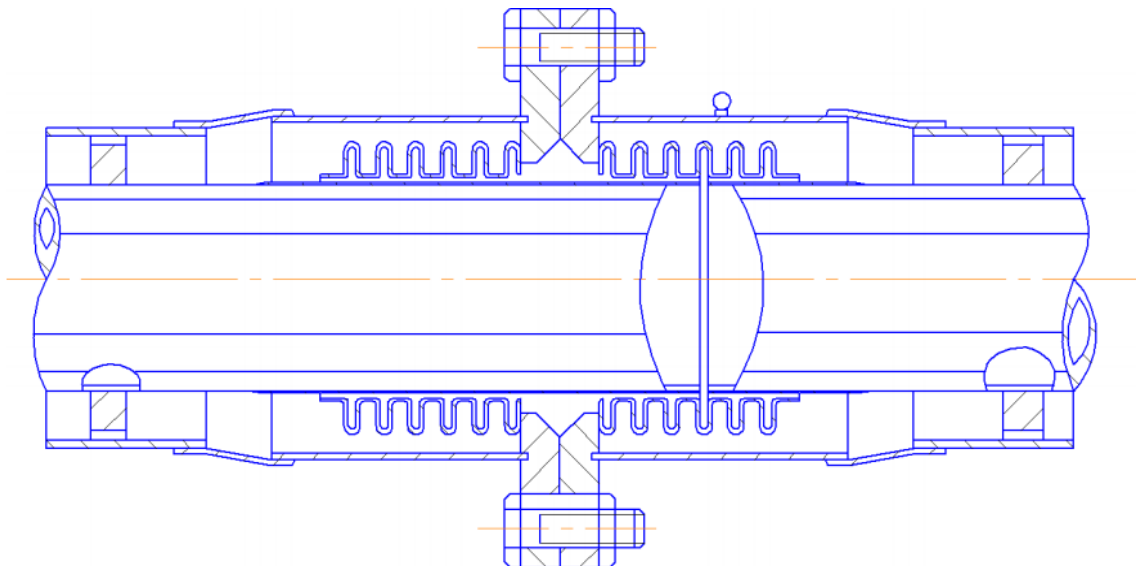

Figure 18: Connecting a Cryogenic Pipeline Section Using Bellows⁵⁶

Pumping during manufacture and as required during operation is performed through vacuum valve installed on external pipeline. A vacuum sensor and a safety membrane are mounted on it. A variant of the integral welded structure is shown in Figure 19. During the installation of such a pipeline, the inner pipes 1 are first butt welded, then insulation is applied to this area, after which the casing 4 is welded.

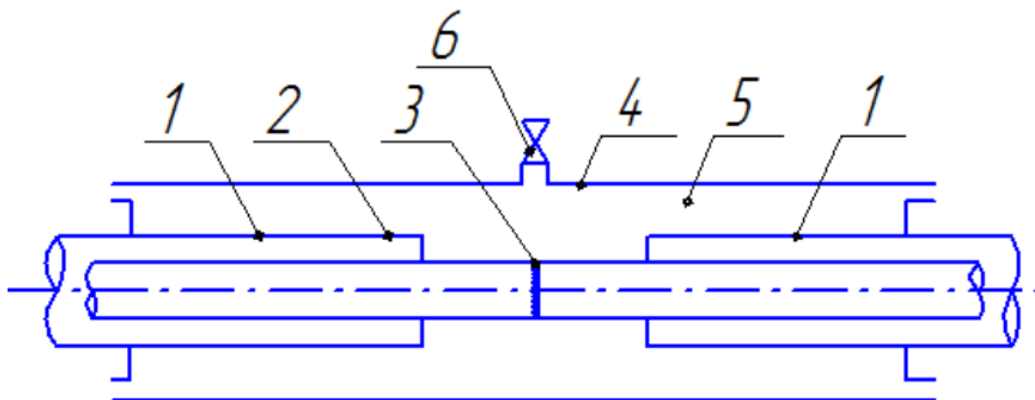

Figure 19: Permanent connection of the pipeline section with vacuum insulation

The most acceptable is the design of a three-layer shell pipeline - pipe-thermal insulation-steam-hydraulic insulation-mechanical protection. It is expedient and economical to combine the vapor-insulating and protective coatings. But for the full implementation of this design in Russia (with various climatic and soil conditions), an unconventional approach to the choice of design for one or another pumping technology and the method of their strength calculation is required. Therefore, it is necessary to develop new and develop known structures in full-

⁵⁶ Kaganer, M. 1966. Thermal insulation in low temperature equipment. Mechanical engineering, vol.12, pp.42-56.

scale conditions for LNG pipelines, as well as to develop methods and conduct comprehensive comprehensive studies.

To successfully solve the problem of LNG design pipeline, it is necessary to create structural units and elements for this new class of pipelines, carry out their research and analysis in order to ensure reliable operation.

As can be seen from the above, there are various cryogenic piping designs capable of providing a sufficiently low level of heat input to the LNG, but the transport efficiency is largely dependent on the transport method adopted.

Schematic diagram of liquefied natural gas transfer is given in Figure 20.

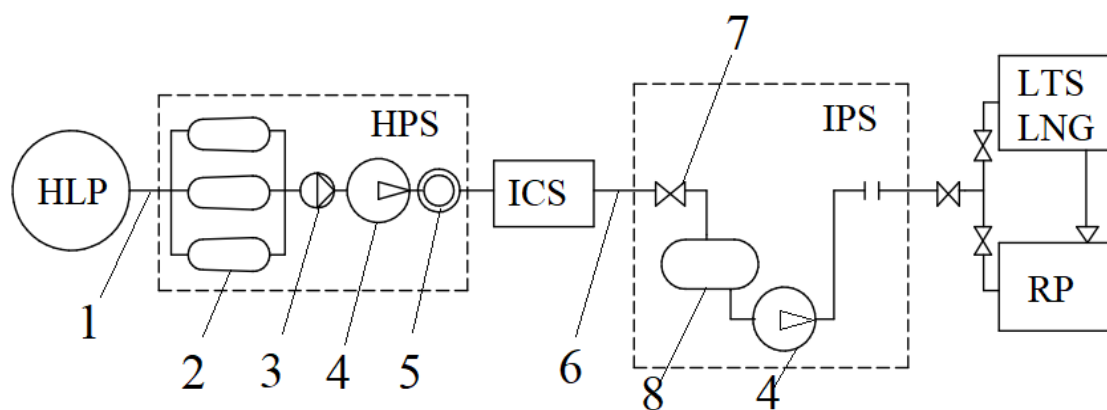

Figure 20: LNG Transfer Schematic Diagram

Where 1 is the supply pipeline, 2 – receiving vessels; 3 – pressure pump; 4 – main pump; 5 – gas metering unit; 6 – main cryogenic pipeline; 7 – regulator; 8 – buffer capacity; HLP – head liquefaction plant; HPS – head pump station; ICS – intermediate cooling station; IPS – intermediate pumping station; LTS LNG – low-temperature LNG storage; RP – regasification plant.

2.4.2 Impact of the construction method on the design features of the cryogenic LNG pipeline

Initial stresses accumulate in the body of the cryogenic pipeline structure due to the imperfect and insufficiently effective technology of its construction. This is due to its vertical movement during laying.

One of the important tasks for the operational reliability of the LNG pipeline is to diagnose and monitor both its individual elements and the structure as a whole and the impact of the environment on it during its operation.

Experimental and laboratory studies⁵⁷ showed that local and linear stresses are distributed over the entire area of the pipeline shell and concentrated in hazardous areas. The dangerous areas are compensating elements, rotation angles of the pipeline route, sections of pipe transitions from soil to surface. These stresses arise in most cases from pipe movements under the influence of temperature drop and external influences with stress concentration in hazardous areas. This can result in external and internal defects, especially when exposed to cyclically low ambient air temperatures and cryogenic pumped product temperatures, resulting in brittleness of the pipe metal.

For this reason, the construction of cryogenic LNG pipelines, in addition to the rules and specifics for conventional gas pipelines, has its own fundamental differences that significantly affect the technology of the structure. The most important difference is the ban on the use of the classic layout scheme using pipe laying machines.

According to the described technical, technological and environmental requirements for the construction of a cryogenic LNG pipeline, it is required to create a new technology for the construction of such facilities and experimental studies with the development of methods for determining stress-strain state (SSS) during the construction work.

In recent years, new technologies have been proposed to monitor the condition of the pipeline using the latest technical means. Such means are radio-controlled and non-controlled pistons, which move inside the pipeline cavity and record defects and stresses in the pipe body.⁵⁸ The problem is that such devices are not able to give perfectly accurate readings of stress associated with corrosion destruction, which is not enough for a responsible facility such as a cryogenic pipeline.

Required diagnostic methods shall be able to record stress-strain condition during all operation periods without operator involvement and pipeline shutdown. The monitoring system shall transmit the values of stress values in the soil, heat inflows to the cryogenic product and transmit this data to the operator at each moment of time and at each site, since the prompt transmission of such information will determine the influence of the parameters on each other and eliminate a potential malfunction and prevent an accident.

For cryogenic LNG piping technology, a pipe laying method shall be used which will exclude significant vertical and horizontal movements of the plies. In the United States, special vessels are used to build pipelines through water barriers without significant pipe movements. These vessels, however, cannot be applied in the conditions of Russia, especially for the northern regions of the country due to the lack of the possibility of

⁵⁷ Polozov, A. 1986. Application of construction materials in the oil and gas industry. Prospects for development of gas pipeline main systems, vol.18, pp.100-105.

⁵⁸ Dedeshko, V., Salyukov, A., Parfyonov, A. 1998. Maintenance and repair of main gas pipelines. Gas production, vol.21, pp.57-59.

delivering such a vessel to the places of construction. The essence of the laying technology is that it uses float systems that keep the pipeline afloat, pre-mounted and stretched over the water barrier transition distance, without bends. After the pipeline is positioned above the design site, the floats are cut and the pipeline is immersed in the design position due to the weight of the ballasting devices. As mentioned, due to the harsh climatic and hydrogeological conditions of Russia, this method is of little use.

The possibility of creating cryogenic pipelines is achieved due to the use of cold-resistant materials of pipe steels. During the construction and operation of these pipelines, it is necessary to determine and consider the stress-strain state of the metal at any time, both in each section of the main and throughout the entire length of the pipeline. For selection of technical means for determination of cryogenic pipeline metal deformations it is necessary to consider structural and technological features of the pipeline:

- Cryogenic pipeline interaction with environment and process equipment;
- Four types of pipeline laying (underground, semi-underground, ground and above-ground);
- Selection of effective thermal insulation structure;
- Pipeline cooling at first start-up or after shutdown;
- Piping in different soils;

The main factors that create a dangerous stress-strain state of the pipeline are:

- Extremely low cryogenic temperature of transported liquefied natural gas;
- Significant temperature drop on the pipeline leading to its displacement;
- High working pressure in the pipeline;
- Residual process stresses remaining after construction and installation works;
- Interaction of the pipe-heat insulation-soil system.

Cryogenic LNG pipelines shall be classified as high risk facilities and complex engineering facilities which consist of pipelines, taps, passages, isolation valves, emergency closing valves, Heat insulating structures.

2.4.3 Characteristics of cold resistant steels for cryogenic LNG pipelines

One of the most expensive capital expenditures for the construction of a cryogenic LNG pipeline is pipe steel, the cost of which reaches 60-70% of the total investment in construction. The choice of cold-resistant steel is limited to the use of proven nickel-added alloys such as Kh18N10T or foreign ASTM 553 steels. Austenitic high nickel steels⁵⁹ are widely used in the construction of cryogenic pipelines. Unlike the construction of cryogenic

⁵⁹ Antoshin, A., Chaburkin, V. 1976. Process strength of welded cold-resistant low-alloy pipe steels. VNIIST, p.176.

pipelines abroad, in Russia the length and scale of construction is much greater than due to large investments.

Cold resistance of cryogenic steels is achieved due to obtaining fine-grained structure by reducing content of carbon in composition and content of harmful impurities. Also, in order to achieve high strength and resistance to temperature differences, heat treatment is carried out. When smelting in furnaces, steels are rolled onto a sheet with a thickness of 10.5-11 mm longitudinal or transverse rolling scheme with heating of the layers to 1300°C.

The metals of the pipes produced from nickel-free steel 12GAFU, after double hot-straightening with reheating in the intercritical temperature range, by uniformly distributing the structural components and balancing the ferrite, correspond to the properties required for the construction of cryogenic LNG pipelines.⁶⁰

Cryogenic pipelines should be based on brittle fracture resistance of cryogenic steels, which successfully withstand very low negative temperatures, when determining whether they meet the operating conditions.

A study of the properties of these steels is given in the studies⁶¹, which helped to clarify the requirements for LNG pipes given in Table 2.

Table 2: Requirements for mechanical characteristics of pipe metal for LNG cryogenic pipelines

Temporary rupture resistance, MPa (kgf/mm ²)	Yield strength, MPa (kgf/mm ²)	Specific elongation, %	Impact toughness, J/cm ² (kgf/cm ²) at temperature 120°C according to GOST 9454-60	
GOST 10006-73			Type 1	Type 2
> 510 (52)	> 353 (36)	> 21	> 86 (8)	> 29 (3)

The final conclusion on the operability of the steel can be carried out by calculation and based on experimental data on the example of real objects, taking into account effective designs of cryogenic LNG pipelines. The values obtained must be compared with the regulatory framework that need to be developed. The standard calculation of the gas pipeline does not take into account the fatigue factor, which is unacceptable in relation to cryogenic LNG pipelines.

When constructing cryogenic pipelines, it is necessary to select the appropriate metal and its features. It is also necessary to take into account the operation of steel structures under

⁶⁰ Fedosyev, V. 1999. Resistance of materials. Moscow: MVTU Bauman, second edition.

⁶¹ Ivantsov, O. 1968. Transport and storage of liquefied gas in France. Moscow: VNIOENG, p.12-14.

various temperature operating conditions, the operation of welds and their impact on accident-free operation.

In factory conditions for cryogenic pipes, it is estimated that it is advisable to use electrode wire of grades SV-10NMA or SV-06NEA with low-temperature fluxes AN-15M, AN-20 or AN-43.

However, do not do without welding pipes at the site of the structure, in the field. Under such conditions it is possible to form cold cracks in the welding zone. In order to avoid defects, the requirements for temporary resistance, yield strength, elongation and toughness in manual welds at negative temperatures⁶² must be carefully studied. Thus, the selection of welding materials and electrodes for cryogenic steels is still an open question.

2.5 Interaction of underground pipeline and permafrost soil

Underground main pipelines laid along the territory with the spread of permafrost rocks have a number of features related to the fact that during the operation of pipelines their technological elements interact with frozen soils, which can cause the activation of hazardous geological processes and lead to accidents and failures.

During operation, the underground section of the main pipeline is under conditions of multifactorial loading and environmental influence.

All types of loads that act on the pipeline are conditionally divided into two groups:

- Regulatory loads, always in force, to be taken into account when designing the pipeline system;
- Abnormal loads that may occur due to violation of standards during the construction and operation of the pipeline system, as well as the impact of the environment on it.

The main normative loads acting on the underground main pipeline section are:

- Internal overpressure of the transported product;
- Temperature drop;
- Difference between air temperature during pipeline laying and temperature during its operation;
- Weight of pipeline, transported product and backfill soil;
- Nonlinear resistance of surrounding soil to pipeline movement;
- Other loads defined by the design.

⁶² Makarov, E. 1970. Process strength of steel during austenite transformations (cold cracks). Mechanical engineering, vol.12, pp.54-62.

The most common abnormal loads on the underground section of the pipeline are uncontrolled soil movements and the mechanical impact of earth-moving equipment on the pipeline and on the soil massif surrounding it.

The main types of normative and abnormal loads are static. In addition to mechanical loads, a widespread and dangerous factor that reduces the strength reserves of the structure is the corrosive effect of the environment on the walls of pipes in places where the insulation coating is broken. Such an effect causes the appearance and development of local corrosion defects on the outer surface of the pipeline walls.

The following natural processes and phenomena are characteristic of the underground pipeline section operated under conditions of permafrost rocks: cryogenic heaving of soils; ice formation; erosion and thermoerosion; solifluction and landslide formation; thermoclast, which leads to subsidence of the ground surface, emergence of negative forms of relief. During operation under the action of loads and natural geological processes, the pipeline is deformed together with the soil.⁶³ With these effects, structural connections are broken, leading to an increase in sediment, a decrease in the bearing capacity of the pipeline, and a deterioration in physical and mechanical properties.

As a rule, the construction of pipelines on frozen soils is carried out at a time when the soil is in a frozen state, since with seasonal thawing, the passage of construction equipment along the route becomes almost impossible. The initial state of the underground pipeline is determined by the position in the frozen soil of the pipeline, and its stress-deformed state should be calculated taking into account the physicommechanical properties of the frozen soil.

To assess the load capacity of underground pipelines laid in the cryolithozone, two problems must be solved jointly: the problem of thermal interaction of the pipe and frozen soil and the strength problem.

Only stabilized sediments are considered for practical use in pipeline strength calculations of actual process of penetration and subsidence of soil flowing in time. When considering the properties of frozen soil after thawing, it should be borne in mind that when freezing the melted soil, a significant change in its texture occurs and a new cryogenic texture is formed. This process is associated with the migration of water and dispersed mineral particles, with an increase in the volume of water during freezing, with the reduction of mineral particles of the soil and its individual layers with ice crystals.

Soil massif for underground pipeline is medium where deformations of structure develop, at the same time medium resists movement of pipeline. The integrity of the pipeline depends on the characteristics of its stress-strain state in the pipe section.

⁶³ Nikolaev, M., Struchkova, G., Kapitonova, T., Efremov, P. 2015. Geo-environmental risks of pipelines in the north. Current trends in science and education, vol.5, pp.38-49.

The most effective way to predict the stress-deformed state of the pipeline is to simulate its operating conditions using finite element methods in order to analyze its possible behavior under the influence of certain operational loads and external influences.

The main advantages of using the finite element method in numerical analysis are the theoretically proven convergence of this method for elliptical problems and the possibility of using irregular calculation grids, which allows you to model bodies of complex geometric shape with the required accuracy. In addition, for non-uniform structures consisting of structural elements with significantly different mechanical properties of materials, as a rule, only the finite element method can be directly applied.

To implement numerical finite element analysis, the pipeline is defined by beam elements. Pipeline structure is modeled by end elements in the form of rectilinear and curvilinear beams of circular cross section. When constructing simulation models and their subsequent numerical analysis, all loads that significantly affect the total stress-strain state of the pipeline are taken into account.

Soil resistance of deformation of underground sections of pipelines is simulated by setting nonlinear links by three translational degrees of freedom at node points of finite-element model. Parameters of these links are calculated for each final element by formulas of engineering models of interaction "pipeline - soil".⁶⁴

To simulate soil reactions, local coordinate systems are created successively for each of the pipeline model nodes, oriented along the pipe so that the directions of the axes of the local coordinate system correspond to the longitudinal, vertical and horizontal directions of the pipeline axis.⁶⁵ For each pipe model node, 3 copy nodes are created with rigid seals, each of which models the soil resistance when the pipeline moves in vertical, horizontal, and longitudinal directions. Each element has corresponding properties, which determine the direction of action of the spring and the power characteristic.

Force characteristic of each spring is described by analytical expressions defining flat deformed state of soil massif surrounding pipeline.⁶⁶

The resistance of the soil to lateral downward movement of the pipe is described in a trilinear diagram of the form:

⁶⁴ Seleznyov, V., Alyoshin, V., Pryalov, S. 2016. Basics of Numerical Modeling of Main Pipelines. Moscow:MAKS Press, second edition.

⁶⁵ Alyoshin, V., Seleznyov, V., Klinin, G., Kobayakov, V. 2015. Numerical analysis of underground pipelines strength. Moscow: Editorial RF.

⁶⁶ Aynbinder, A. 2015. Calculation of main and field pipelines for strength and stability. Moscow: Nedra.

$$q = C_{oc} \cdot v \cdot D_o < \text{if } v \leq S_{oc}, \quad (\text{Eq.1})$$

$$q = [C_{oc} \cdot S_{oc} + (v - S_{oc})] \cdot D_o \text{ if } S_{oc} < v < S_{oc} + \frac{R}{C_{yo}} \quad (\text{Eq.2})$$

$$q = R \cdot D_o \text{ if } v \geq S_{oc} + \frac{R}{C_{yo}} \quad (\text{Eq.3})$$

Resistance to transverse upward movements is described in a four-line diagram of the form:

$$q = C_n \cdot v \cdot D_o \text{ if } v \leq \frac{q_{pb}}{C_n \cdot D_o} \quad (\text{Eq.4})$$

$$q = q_{pb} + \left[v - \frac{q_{pb}}{C_n \cdot D_o} \right] \cdot C_{yo} \text{ if } \frac{q_{pb}}{C_n \cdot D_o} < v < \frac{q_{pb}}{C_n \cdot D_o} + \frac{q_{np.soil}}{C_{yo} \cdot D_o} \quad (\text{Eq.5})$$

$$q = q_{pb} + q_{np.soil} - \left[v - \left(\frac{q_{pb}}{C_n \cdot D_o} + \frac{q_{np.soil}}{C_{yo} \cdot D_o} \right) \right] \cdot C_p \text{ if } \left[\frac{q_{pb}}{C_n \cdot D_o} + \frac{q_{np.soil}}{C_{yo} \cdot D_o} \right] < v < h \quad (\text{Eq.6})$$

$$q = q_{pb} \text{ if } v \geq h$$

Where, q – ground resistance (kN), q_{pb} – pipeline bouyanancy (kN), $q_{np.soil}$ – maximum soil holding capacity above the pipe (kN), C_n , C_{yo} , C_p , C_{oc} – correspondingly the coefficients of the normal resistance of the melted soil, the unloading coefficient, the coefficient of the normal resistance of the subsidence soil; v – soil displacement factor, D_o – external (outer) pipeline diameter (m), h – backfill height above pipe (m), R – design resistance of melted soil kN/m², S_{oc} – amount of subsidence (mm).

In engineering models, the nonlinear dependence of the soil resistance force on pipe movements is linearized using idealized Prandtl bilinear diagrams. Such idealization is a common approach to the development of domestic and foreign engineering models. Prandtl diagrams are built for three main directions of pipeline movement in the ground - longitudinally, transversely in vertical and horizontal planes. Results of experimental verification of engineering models of pipe-soil interaction⁶⁷ indicate that using idealized diagrams it is possible to obtain satisfactory estimates of soil resistance force to pipeline movements during practical calculations. When laying a pipeline in permafrost soils, the

⁶⁷ <https://uralrezerv.com/emkosti-dlya-hraneniya-i-transportirovki/tank-kontejnery>, accessed 02.04.2021

amount of soil subsidence under the pipeline depends on the following factors: depth of permafrost soils, thawing halo, position of the pipeline axis relative to the day surface, its diameter. The depth of soil penetration under the pipe can be determined by the Forchheimer formula:⁶⁸

$$h = -\frac{a \cdot (1+b)}{1-b} \quad (\text{Eq.7})$$

$$a = \sqrt{h_0 - \frac{D_o}{4}} \quad (\text{Eq.8})$$

$$b = \sqrt{\exp\left(\frac{2 \cdot T_{soil} \cdot \ln \frac{4 \cdot h_o}{D_o}}{\frac{\lambda_{tc}}{\lambda_i} \cdot T_{wall} - T_{soil}}\right)} \quad (\text{Eq.9})$$

Where T_{soil} – soil temperature (°C), T_{wall} – pipe wall temperature (°C), λ_{tc} – thermal conductivity coefficient of melted soil (W/(m·°C)), λ_i – thermal conductivity coefficient of frozen soil (W/(m·°C)).

2.6 Basis of calculation of strength and stability of cryogenic LNG pipelines

The creation of a pipeline with a low working medium temperature in special conditions - permafrost soils is a difficult problem, and requires solving problems of strength, stability, reliability. For the approximate calculation of stresses in ordinary pipelines arising from the pressure and temperature of the product in their walls, engineering formulas are used:

$$\sigma_p = \frac{\mu \cdot D_o \cdot \Delta P}{2 \cdot \delta}, \quad (\text{Eq.10})$$

$$\sigma_t = \alpha \cdot E_m \cdot \Delta T \quad (\text{Eq.11})$$

Where, μ is the transverse deformation coefficient (for steel on average $\mu = 0.3$), ΔP is the internal pressure drop (MPa), δ is the pipe wall thickness (mm), α is the thermal expansion coefficient, E_m is the modulus of elasticity of pipe metal, ΔT is the pipe wall temperature drop (°C).

In practical conditions of complete pinching of the pipeline, as a rule, if there are no turning angles, it does not occur, since natural compensation is carried out due to the terrain and

⁶⁸ <http://cryoservice.ru/wp-content/uploads/2015/02/truboprovody-statiya.pdf>, accessed 04.04.2021

fresh backfilling with soil. In this case, partial compensation of both σ_t and σ_p stresses occurs. Temperature stresses in the pipeline under conditions of their partial compensation due to longitudinal movements can be taken into account when knowing the value Δt , as well as relative elongation ε_{pipe} in the axial direction. In case of complete clamping of the pipeline, stresses in the walls of its pipe are determined as the sum of temperature stresses and stresses causing longitudinal deformation of the pipeline. Considering that the latter may result from externally applied forces (mechanical stresses), the expression (10) will take the form:

$$\sigma = \sigma_t + \sigma_\varepsilon \quad (\text{Eq.12})$$

$$\sigma_t = \alpha \cdot E_m \cdot \Delta T$$

$$\sigma_\varepsilon = \varepsilon \cdot E_m$$

$$\Delta T = T_1 + T_2$$

The sign of relative deformation is taken as normal: when lengthening "+," when shortening "-". With a perfectly "complete" pinching of the pipeline and no other influencing factors other than temperature, it is obvious that no longitudinal deformation of the pipeline will be observed and therefore:

$$\sigma_\varepsilon = 0$$

$$\sigma = \sigma_1 = -\alpha \cdot E_m \cdot \Delta T$$

If there is no pinching and if the ends of the pipeline are free, the internal stresses will be absent ($\sigma = 0$) and the pipeline will change its length according to the temperature change. At the same time relative deformations of the pipeline:

$$\varepsilon = \alpha \cdot \Delta T \quad (\text{Eq.12})$$

By applying the Δt and ε to the formula, we get:

$$\sigma_t = -\alpha \cdot E_m \cdot \Delta T$$

$$\sigma_\varepsilon = \varepsilon \cdot E = \alpha \cdot \Delta T \cdot E_m$$

$$\sigma = -\alpha \cdot E_m \cdot \Delta T + \alpha \cdot \Delta T \cdot E_m = 0 \quad (\text{Eq.13})$$

In the case of pinching, which does not guarantee the absence of longitudinal movements of the pipeline, a change in temperature causes longitudinal movements and at the same time the appearance of internal stresses in the pipeline.

Let's assume:

$$\Delta T = \Delta_1 \cdot T + \Delta_2 \cdot T$$

Where, $\Delta_1 t$ is the part of the temperature difference that caused the longitudinal movements, $\Delta_2 t$ is the part of temperature difference, which caused internal stresses in the pipe. In this case, stresses in the pipeline caused by temperature change:

$$\sigma = \sigma_t = -\alpha \cdot E_m \cdot \Delta_2 T \quad (\text{Eq.14})$$

And relative elongation:

$$\varepsilon = \alpha \cdot \Delta_1 T \quad (\text{Eq.15})$$

If we use formula (11) for this case, we get:

$$\sigma_t = -\alpha \cdot E_m \cdot \Delta T$$

$$\sigma_\varepsilon = \varepsilon \cdot E_m = \alpha \cdot \Delta_1 \cdot T \cdot E_m$$

$$\sigma = -\alpha \cdot E_m \cdot \Delta T + \alpha \cdot \Delta_1 \cdot T \cdot E_m = -\alpha \cdot E_m \cdot (\Delta T + \Delta_1 T) = -\alpha \cdot E_m \cdot \Delta_2 \cdot T$$

From this it follows that under any conditions of clamping of the pipeline, stresses in the walls of its pipe from temperature change can be determined by formula (11). If there are external mechanical effects on the pipeline, for example, from the side of transverse soil movements, the calculation of external forces in the pipeline can also be carried out according to formula (11). In this case, σ_ε will take into account stresses caused by external mechanical factors. Just as for stresses caused by temperature drop, it is possible to bring for stresses from internal pressure. It is taken into account that when the internal pressure changes on ΔP , voltages will appear (in case of "full" pinching).

$$\sigma_p = \frac{\mu \cdot D_o \cdot \Delta P}{2 \cdot \delta} \quad (\text{Eq.16})$$

Or longitudinal deformations:

$$\varepsilon = -\frac{\sigma_p}{E_m} = -\frac{\mu \cdot D_o \cdot \Delta P}{2 \cdot E_m \cdot \delta} \quad (\text{Eq.17})$$

In case of joint influence of temperature difference, changes of internal pressure and external mechanical factors, stresses in the pipe walls are determined by the formula:

$$\sigma = \sigma_p + \sigma_t + \sigma_\varepsilon \quad (\text{Eq.18})$$

Where, σ_ε is the stresses calculated taking into account parameters taken on the real pipeline by MPa instrument methods. Eq.18 can also be used to determine stresses in the walls of above-ground pipelines.

3 Theoretical and design basis

3.1 Theoretical basis of strength calculation

Pipeline calculations are based on the rules of construction mechanics, which take into account the total longitudinal stresses arising in the element of the cylindrical wall of the pipe, in the most loaded area with an unfavourable combination of design loads.

Note that non-design loads in the framework of the study are taken into account by the accepted double safety factor (for comparison, for the highest category of pipeline according to the current regulatory document⁶⁹, it is 44%, $m = 0.66$). And also due to underestimated average strength indices of the accepted steel grade for construction (Table 2).

Table 3: Requirements for mechanical properties of steel according to ASTM A353, A553⁷⁰

Standart	σ_t , N/mm ²	σ_y , N/mm ²
ASTM A353	690-825	≥515
ASTM A553	690-825	≥585

For the present studies, when checking the condition of double safety factor, the minimum possible value of yield strength is $\sigma_y = R_2 = 515$ MPa and the average value of the represented range of strength change $\sigma_t = R_1 = 750$ MPa.

When calculating pipelines for strength, models of thin-walled (for ground structures) and thick-walled (for underwater sections) cylindrical shell are used. In our case, taking into account the previously estimated design wall thickness (10-15 mm) for diameter $D_o = 114,3$ mm, a model of a thin-walled shell is adopted. (Figure 21)

⁶⁹ Set of Rules «SP» 36.13330-2012. Trunk pipelines.

⁷⁰ Matrosov, M., Zikeev, V., Martinov, P. 2016. Development of promising cryogenic steels for gas carriers and stationary storage tanks of liquefied natural gas for use in Arctic conditions. Shipbuilding for the Arctic, vol.4, pp.80-89.

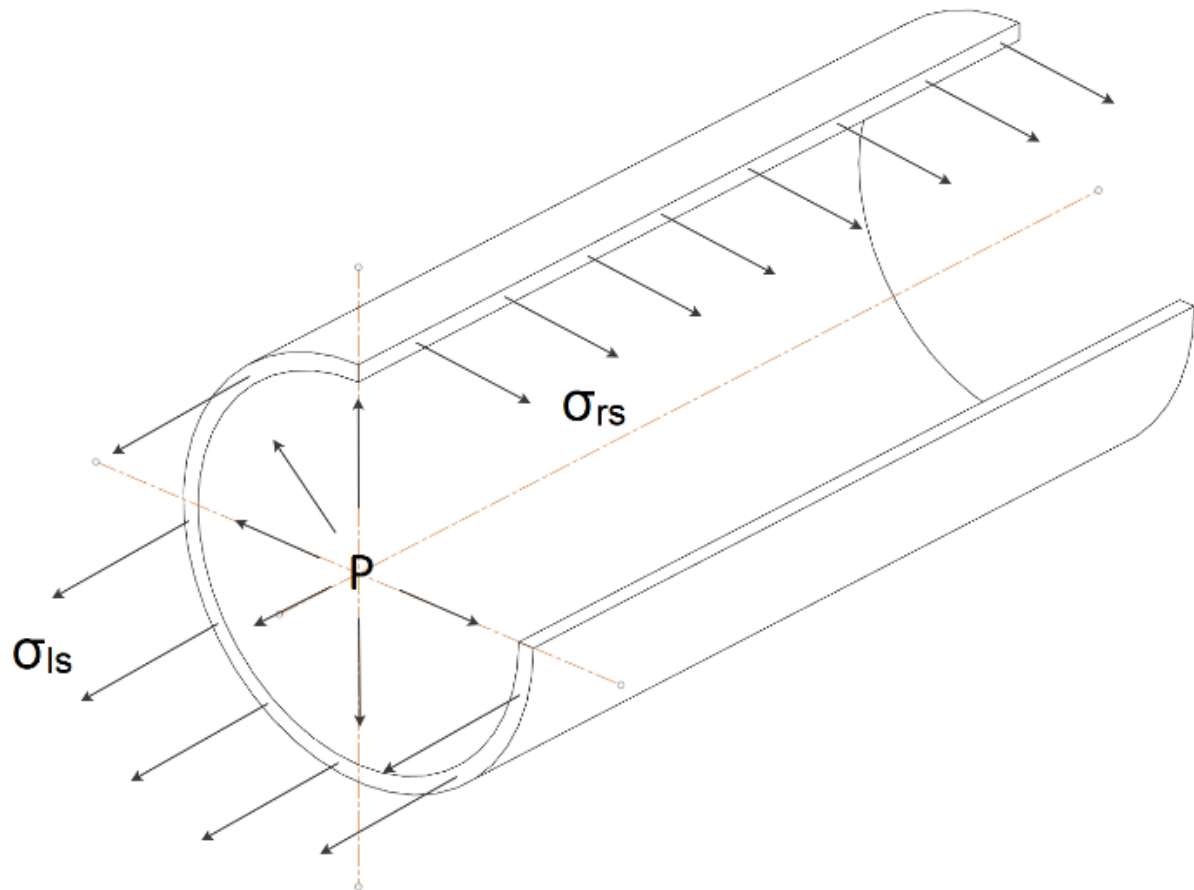

Figure 21: Stress arising in the thin-walled model of the cylindrical shell⁷¹

The essence of the calculation is to determine the value of the equivalent stress in the most dangerous section. The most dangerous section in our case corresponds to the minimum operating temperature, the maximum pressure and the minimum radius of elastic bending. Based on this, maximum loads will be observed in the initial section ($P_{initial} = 15 \text{ Mpa}$, $T_{product} = -160^\circ\text{C}$).

The preliminary wall thickness for finite element model creation in Ansys was calculated according to equation 19 without taking into account the load safety factor (taken into account by the total margin of double strength $R_1 = 0,5$).

⁷¹ https://edu.truboprovod.ru/kbase/doc/start/WebHelp_ru/troiniksnp.htm, accessed 06.04.2021.

$$\delta = \frac{P \cdot D_o}{\rho_{\min}} \quad (\text{Eq. 19})$$

Where P - pressure; ρ_{\min} - minimal radius of elastic bend.

Maximum longitudinal stresses are determined by equation 20:

$$\sigma_{ls} = \mu \cdot \sigma_r - \alpha_T \cdot E \cdot \Delta T \pm \frac{E \cdot D_o}{2 \cdot \rho_{\min}} \quad (\text{Eq. 20})$$

Where μ - Poisson's coefficient; σ_r - radial stresses; α_T - coefficient of thermal expansion; E – Young's modulus; ΔT - temperature difference.

The most dangerous case will always correspond to sections subject to tensile and annular stresses, stresses from the temperature difference (the pipe section is fixed on reinforcement units and is stretched during cooling due to linear reduction of metal), on elastically curved sections.

The strength conditions for the model created by the method of finite elements will be as follows (Eq. 3, 4):

$$\sigma_{ls}^{\max} < 0,5 \cdot R_1 \quad (\text{Eq. 21})$$

$$\sigma_{ls}^{\max} < R_2 \quad (\text{Eq. 22})$$

To solve this problem, in the design environment of Ansys, a model was developed using the finite element method, an elastically curved section of the pipeline rigidly fixed in the units of the shutoff valves installation (20 km).

Due to the estimated nature of the calculation, the influence of the thermal insulation weight and the possibility of violation of the design position are not taken into account. This assumption is due to the very low thermal insulation weight with high thermal insulation properties⁷² (aerogel). And also, with the exception of the negative impact of the pipeline temperature on the possibility of soils melting (cryogenic conditions contribute to the strengthening of frozen soil - the heat flow is directed from the soil to the pipe). The estimated design diagram of the elastically curved pipeline is shown in Figure 22.

⁷² <https://www.popmech.ru/made-in-russia/249842-kak-sozdat-aerogel-novosibirskie-eksperimenty/>, accessed 06.04.2021.

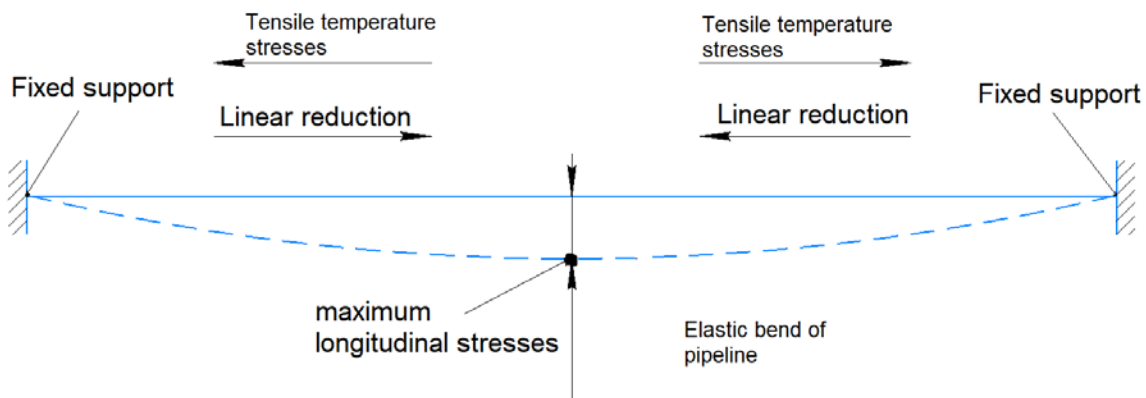

Figure 22: Estimated design diagram of elastically curved pipeline

As input for the finite element model in Ansys, it is necessary to define the heat and hydraulic parameters of the transfer (pressure and temperature), elastic bending radii for calculation, accepted and varied from $500 D_o$ (as for offshore pipelines made of steel of increased strength), $1000 D_o$ (according to the requirements of regulatory documents⁷³ for main pipelines) and $1500 D_o$ (actually straight section laid on supports).

The reference point when calculating the temperature difference is the closing temperature of the last weld at the closure of the whole section, taken according to the warmest average monthly temperature in summer for the construction area.

In order to reduce metal consumption (wall thickness) and the number of required compensators (if the strength condition for the maximum wall thickness for the selected diameter is not met).

As part of the study, the possibility of reducing temperature loads by limiting the maximum installation temperature (performing closure of joints on the coldest day in winter) was considered.

3.2 Characteristics of the construction area

Calculations were made on the example of an underground section of the pipeline transporting liquefied associated petroleum gas (LAPG) produced and liquefied to critical conditions at low-debit mined deposits in Eastern Siberia.

In particular, the design of a cryogenic pipeline from the Kuyumbinsky and Tersko-Kamskoye fields («Rosneft», «Krasnoyarskneftegaz») to the nearest settlement of Baikit is being considered. Figure 23

⁷³ Set of Rules «SP» 36.13330-2012. Trunk pipelines.

Associated petroleum gas pumped in liquefied form is used for power supply and heat supply of the city and as refueling fuel.

The warmest average monthly temperature of the summer period is accepted according to climatology directories⁷⁴ and is 24.5°C.

The pipeline gas capacity under standard conditions is 10,000 m³/day, which is enough to load a small gas distribution station that feeds medium settlements without large industrial consumers.

As a backup option for gas supply in case of failures and emergency situations, LAPG is delivered in cryogenic tank containers for a distance of not more than 200 km during winter periods. Winter periods are chosen due to the most favorable conditions for cryogenic fluid due to low ambient temperature and the possibility of ground movement during the operation of winter roads.

During summer periods, fuel consumption is greatly reduced, so there is no redundancy in the project.

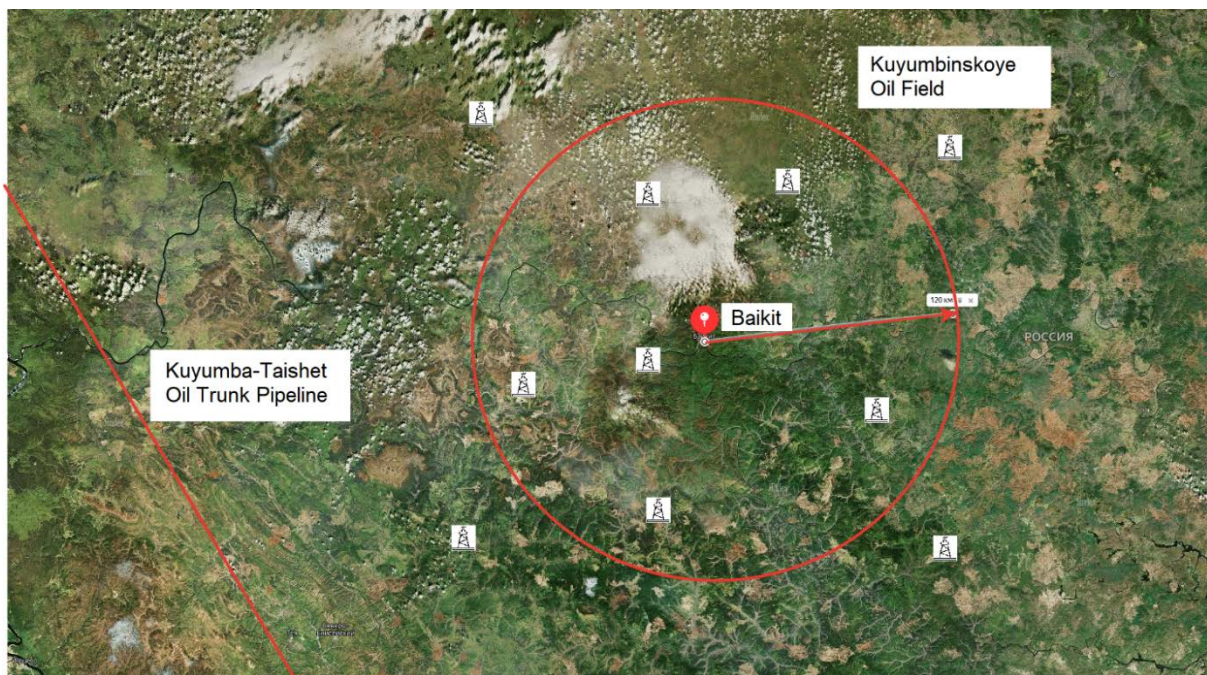

Figure 23: Construction area overview

Baikit is a settlement in the Evenkiyskiy district of the Krasnoyarskiy Kray. The settlement is located on the right bank of the Podkamennaya Tunguska River, 350 km southwest of the administrative center of the district - the settlement Tura. The adjacent area is a plateau with

⁷⁴ <https://nn.vo-da.ru/tool/cp-info>, accessed 10.04.2021

altitudes of 500-600 - meters above sea level. The climate in the region is sharply continental with an average annual air temperature of 6.3 °C.

Kuyumbinskoye oil and gas field is located in the Evenkiyskiy district of the Krasnoyarsk Kray, mainly on the left bank of the Podkamennaya Tunguska River. It was discovered in 1973 by drilling the Kuyumbinskaya-1 well, which opened massive oil and gas deposits. In 2013, according to exploration works, the reserves of the field amounted to about 281 million tons. oil. The company is developing this field Slavneft-Krasnoyarsk Neftegaz. A significant part of the enterprise's discovered deposits is located on the Kuyumbinsky license area and the Northeast section of the Tersko-Kamovsky block, which are part of the Yurubcheno-Tokhom oil and gas accumulation zone.

To date, the Kuyumba-Taishet pipeline transports the produced oil through the Transneft main pipeline energy system, while the gas issue has not been resolved due to the fact that the field is under development and today associated oil gas is simply burned (the average value of the gas factor is 500 m³/1 m³).

At the same time, Baikit itself and nearby settlements are heated with wood and coal, including the center of the Krasnoyarsk Kray - Krasnoyarsk still uses coal. Before the construction of the Power of Siberia pipeline, which is aimed at solving this problem, there is a need to dispose of a large amount of associated gas for energy and heat supply to small settlements.

Since the construction of gas processing plant for low-consumption deposits is economically impractical and there are no large petrochemical centers in the area, the most rational solution is the use of APG after its preliminary preparation as the main source of heat and fuel in the winter.

In summer periods, unclaimed gas volumes can be transported towards Krasnoyarsk in the usual compressed way (after the completion of the Power of Siberia project).

The option of transporting dry associated petroleum gas in a liquefied state was chosen on the basis of favorable in terms of maintaining critical temperatures, as well as low urbanization of the area, which allows laying cryogenic LAPG pipelines dangerous from an industrial safety point of view.

The compressed transportation option loses on the enlarged LAPG pipeline due to higher metal consumption (large diameters), as well as high risks of hydrate formation due to negative temperatures. The solution to the problem of inhibition, as experience has shown, is associated not only with high costs for the delivery and storage of methanol, but also with its poisonous properties that affect both people and the environment.

3.3 Determination of critical conditions and thermohydraulic parameters of non-thermal LAPG transfer mode

3.3.1 MultiFlash

Phase diagrams and critical parameters of gas mixtures in different ratios make it possible to determine, as well as predict the phase behavior of liquefied hydrocarbons at various temperatures and pressures.

This paper discusses the transport of dry associated petroleum gas through a cryogenic pipeline, the component composition of which is shown in Table 4.

Table 4: Component composition of APG

Component	% vol.
Methane	92,4976
Ethane	1,2995
Propane	2,0941
I-Butane	0,5792
N-Butane	0,8135
I-Pentane	0,3062
N-Pentane	0,3017
Hexanes	0,7151
Nitrogen	0,5946
Oxygen	0,0036
Carbon dioxide	0,7949

According to the purpose of the study, the MultiFlash program used the component composition from Table 2 and the PR model (Pang Robinson) to model the fluid. As a result, a phase diagram was obtained (Figure 24), according to which it can be concluded that the transportation of liquefied associated petroleum gas through a cryogenic pipeline in a liquefied state is possible with a temperature range of -84 to -160 ° C at a pressure of at least 4 MPa.

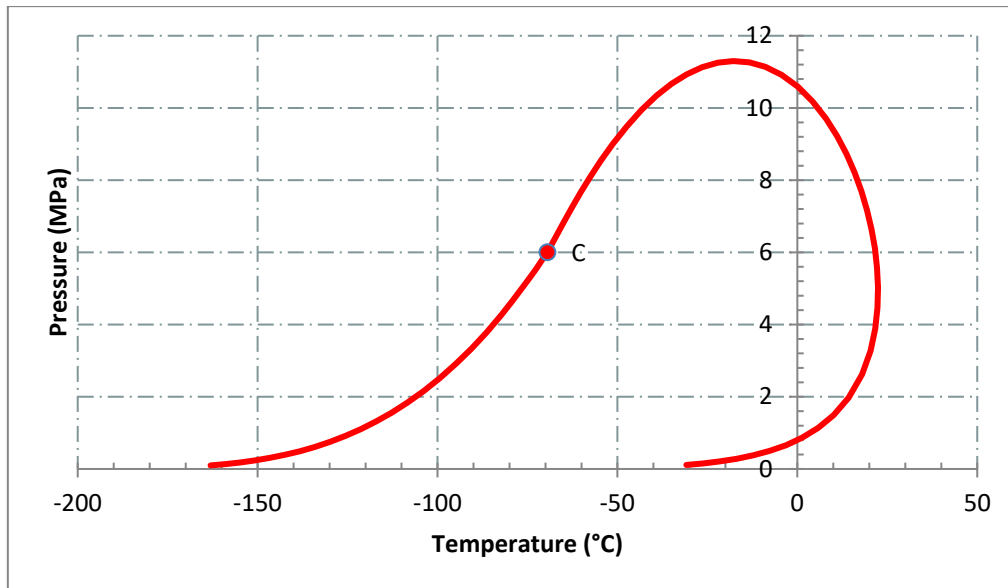

Figure 24: Associated petroleum gas phase state diagram

Using the phase diagram obtained for the associated petroleum gas, it can be stated that in order to maintain the liquefied state, the temperature and pressure values can be varied within acceptable limits to maintain the liquefied state.

Density and viscosity parameters of liquefied APG at 7 MPa and -100 °C are 326 kg/m³ and 4.21*10⁻⁵ Pa/s, respectively.

Distribution of zones to critical and subcritical ones is given in Figure 25.

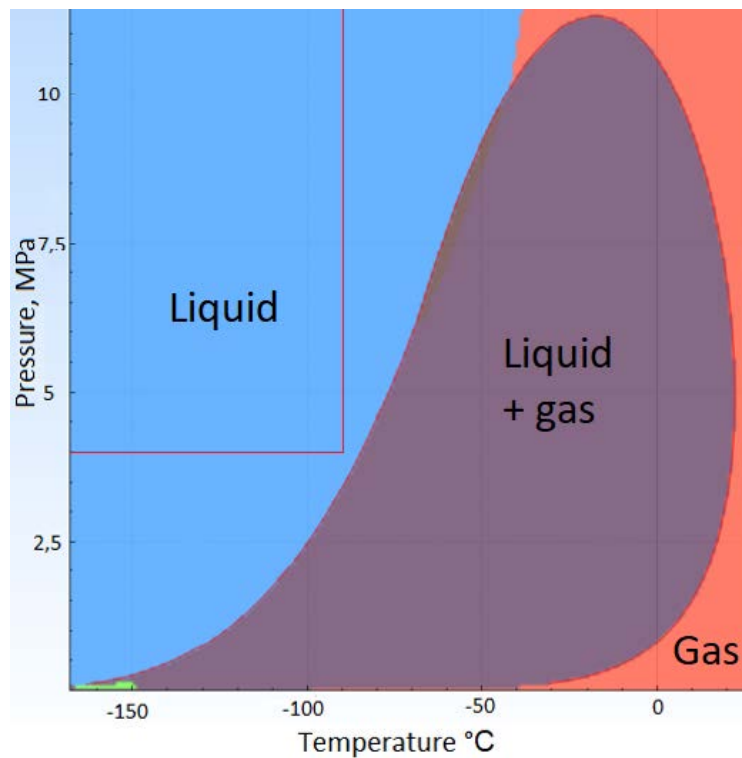

Figure 25: Distribution of phase state zones of fluid used in calculations

3.3.2 Determination of initial parameters of temperature and pressure

Based on the above, cryogenic LAPG pipelines requires very precise determination of optimal pumping conditions. For a pipe with a diameter of 114.3 mm, the final parameters of temperature -90°C and start pressure 15 MPa were adopted for transporting it to a distance of 120 km at the highest monthly summer temperature of the Krasnoyarsk Kray of 24.5°C .

To determine the initial pressure and temperature for the transfer of liquefied LAPG, a study was conducted in the OLGA program. The fluid matrix performed in the MultiFlash was used to set the source data for the model in the OLGA. Data on changes in temperature and pressure of the pumped product in the pipeline at each of its sections were obtained, since the stress-strain state of the structure significantly depends on the change in the cooling depth of the product.

According to the study, the OLGA program obtained the necessary data on the change in temperature and pressure over the total pipeline length of 120 km, which was divided into 6 sections of 20 km. The results of the dynamic simulation are shown in Figure 26, 27 and Table 5.

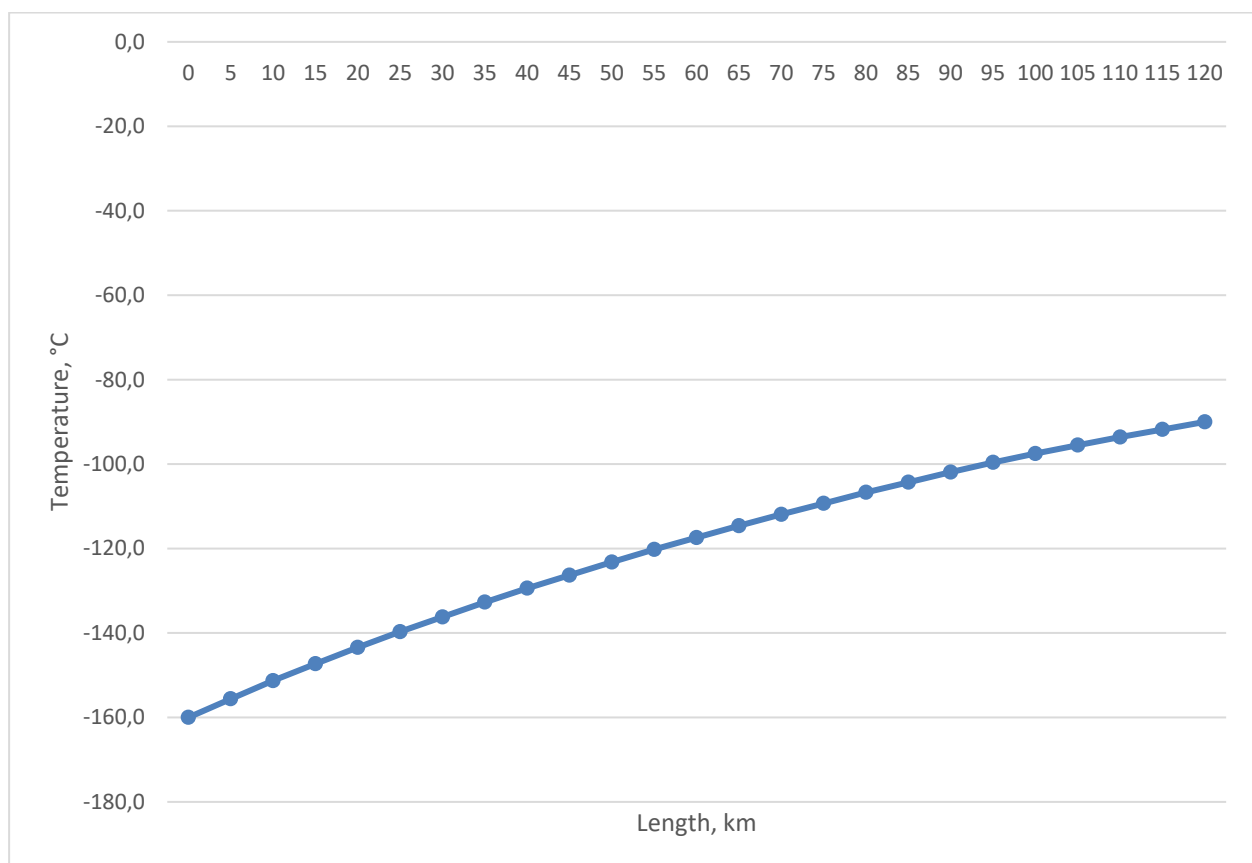

Figure 26: Change of pumped product temperature along pipeline length

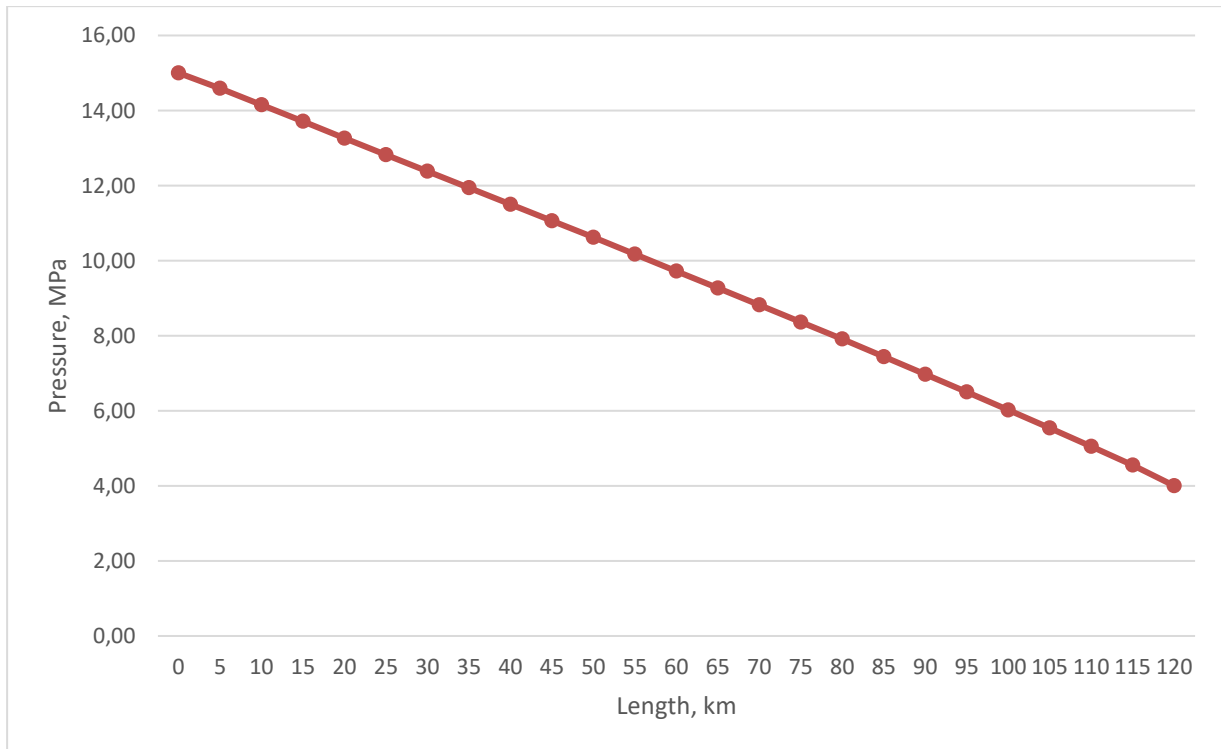

Figure 27: Change of pumped product temperature along pipeline length

Table 5: Pressure and temperature of pumped product in cryogenic pipeline sections

Length, km	Pressure, MPa	Temperature, °C
0	15	-160
20	13,1	-143
40	11,5	-129
60	9,8	-117
80	7,9	-107
100	5,9	-99
120	4	-90

Based on the results of the numerical experiments, the following optimal parameters of the LAPG pipeline for the specified conditions were obtained. Pipeline length not more than 120 km, diameter 114.3 mm, initial filling temperature -160 ° C, final pressure not less than 4 MPa.

The obtained initial pressure and temperature data are within the permissible range, which can be achieved taking into account the existing state of development of technologies and technology used in the production of LAPG and construction of pipelines without significant modifications.

The average distance of the deposits is 100-200 km and the average flow rate is 5000-20,000 m³/day.

The study carried out numerical experiments aimed at optimizing the diameter of the pipeline depending on the diameter and temperature depending on the throughput and maximum length to ensure the possibility of maintaining a stable single-phase pumping mode in a liquefied form.

4 Strength calculation and design optimization for LAPG cryogenic pipeline

4.1 Initial data for simulation

Initial data for model creation using finite element method in Ansys are accepted based on results of thermal hydraulic calculation performed in the preceding chapter taking into account critical conditions, climatogeographic data of construction area and main provisions of regulatory documents for design of main⁷⁵ and field⁷⁶ pipelines.

Initial data in the formulated form are presented in Tables 6 and 7 and in Figure 28.

Table 6: Initial data for calculation

	0-20 km	20-40 km	40-60 km	60-80 km	80-100 km	100-120 km
T installation, °C	24,5					
ρ elastic bend	500 D_o , 1000 D_o , 1500 D_o					
P initial	15	13,1	11,5	9,8	7,9	5,9
P final	13,1	11,5	9,8	7,9	5,9	4

Table 7: Strength characteristics of steel

Steel Standart ASTM 553 type 1	
σ_t - R ₁ - tensile strength, MPa	750
σ_y - R ₂ - yield strength, MPa	515
μ - Poisson's coefficient	0,3
α_t - coefficient of thermal expansion	$1,2 \cdot 10^{-5}$
E – Young's modulus	$2,1 \cdot 10^5$

⁷⁵ Set of Rules «SP» 36.13330-2012. Trunk pipelines.

⁷⁶ Set of Rules «SP» 284.1325800.2016. Oil and gas field pipelines design and execution rules.

D_o - outer diameter of a pipeline, mm	114,3
δ - wall thickness, mm	3, 5, 6, 8, 10, 12, 14
m - safety factor	0,5

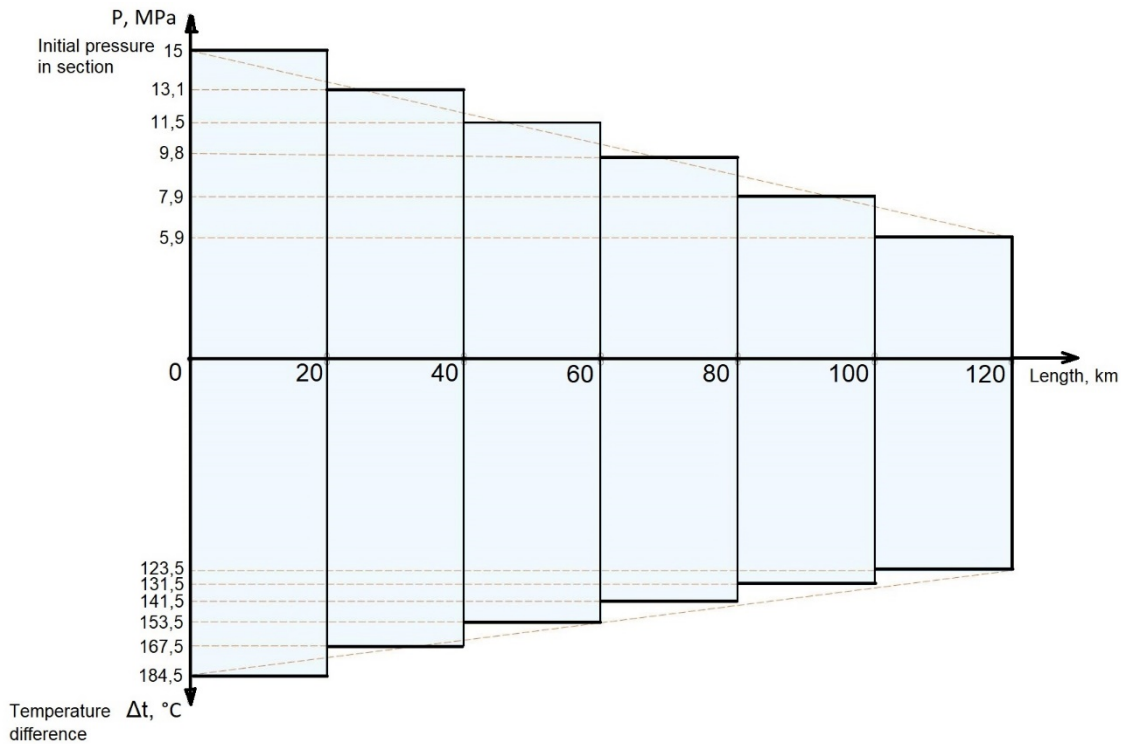

Figure 28: Initial pressure and temperature drop in each pipeline section

Temperature difference is determined for each section by equation 23.

$$\Delta T = T_{operation} - T_{LPG} \quad (\text{Eq.23})$$

To optimize design solutions, the total length of the pipeline is divided into 6 equal parts of 20 km. Each section has rigid sealing on both sides in places of shutoff valves installation. The pressure for each section is taken equal to the maximum pressure obtained in the thermohydraulic calculation, while the temperature is taken according to the minimum operating temperature according to the minimum possible in the section under consideration.

If the strength conditions are not met (Equation 21, 22), several options are possible:

- increase of wall thickness up to maximum in schedule;
- limit the maximum temperature in the last weld of the pipeline;
- increase of pipeline elastic bending radius (from $500 D_o$ to $1500 D_o$);
- installation of compensators.

For the working model, the “pipe 289” and “pipe 16” beam elements were used. 3 types of calculations were performed:

- Calculation of the straight section, to compare the results of the calculation with the results of the calculation in program with the results of calculation using formulas (to make sure, that the model works correctly);
- Calculation of the straight section that was further subjected to elastic bending with a radius of $500 D_o$, $1000 D_o$ and $1500 D_o$;
- Calculating of the compensator.

To perform the first calculation, the straight section of the pipeline was constructed by 4 points, divided into finite elements with a size of $0,5 D_o$ (the length of the finite element is equal to half of diameter of the pipe).

For a second calculation with elastic bending, a section of the pipeline was built at 4 points, showed on the Figure 29. Points 2 and 3 correspond to the starting and ending points of the elastically curved section. Point 2 is fixed, point 3 is forcibly rotated. The locations of points 2 and 3, as well as the angle of rotation, were calculated before.

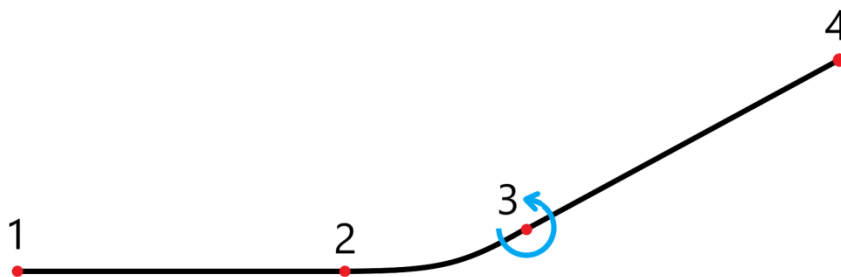

Figure 29: Elastically curved section

As a result, we obtained the necessary bending radius and the following Figure 30:

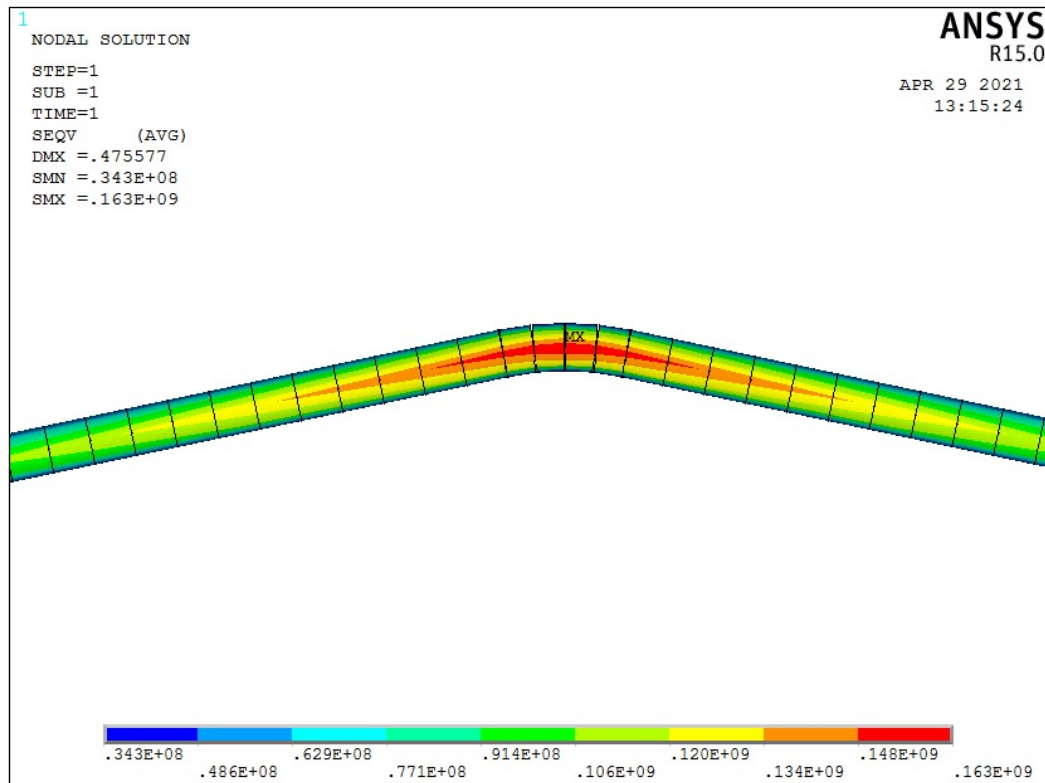

Figure 30: Stress distribution

The Figure 30 shows the size of the finite elements and the stress distribution over the von Mises. Since the element type is beam, not bulk and shell, reducing the size of the finite elements is not required, it does not increase the accuracy of calculations in this case.

The advantage of beam elements is the ability to get results in the form of bending moments, longitudinal and transverse stresses.

In the third type of calculations, the loaded geometry from external source was used (Autocad, Compas 3D). Temperature drop and pressure loads were applied to it.

The following are finite element calculations in Ansys for 6 sections of the pipeline (0-20 km; 20-40 km; 40-60 km; 60-80 km; 80-100 km; 100-120 km)

0-20 km (P=15 MPa, T_{LAPG}=-160)

Results of simulation of stressed deformed state of wall under action of design loads (pressure, temperature difference and elastic bending) at mounting temperature of the last weld joint in 24.5°C (design temperature difference of 184.5°C) are presented in Tables 8 and 9.

Table 8: Preliminary calculation of wall thickness of rectilinear section 0-20 km (mounting temperature 24.5°C)

	Wall thickness, mm						
Stresses	3	5	6	8	10	12	14
Axial, MPa	567,25	517,47	505,03	489,47	480,14	473,91	469,47
Annular, MPa	262,7	148,84	120,42	84,94	63,72	49,63	39,62
Compliance with strength condition must be ≤ 350 MPa Preliminary wall thickness is more than 14 mm							

Results of refined calculation of wall thickness of elastically bent section 0-20 km are given in Table 9.

Table 9: Refined calculation of wall thickness of elastically bent section 0-20 km (mounting temperature 24.5 °C)

Stresses	Wall thickness, mm						
Elastic bend radius, 500D _o	3	5	6	8	10	12	14
Maximum bending stress, MPa	767,25	717,47	705,025	689,4688	680,135	673,9125	669,4679
	Wall thickness, mm						
Elastic bend radius, 1000D _o	3	5	6	8	10	12	14
Maximum bending stress, MPa	667,25	617,47	605,025	589,4688	580,135	573,9125	569,4679
	Wall thickness, mm						
Elastic bend radius, 1500D _o	3	5	6	8	10	12	14
Maximum bending stress, MPa	633,92	584,14	571,69	556,14	546,80	540,58	536,13
Compliance with strength condition must be ≤ 350 MPa Preliminary wall thickness is more than 14 mm							

As can be seen from the presented calculations, the required wall thicknesses exceed the maximum possible in the schedule, the elastic bend 1000 D_o being the most optimal, since its increase in the larger direction is slightly reflected in the total bending stresses.

In order to reduce metal consumption and reduce the cost of construction, subsequent numerical experiments are aimed at reducing the stress level in the most dangerous sections due to limiting the closing temperature of the pipeline, or installing compensators.

Changing the radius of the elastic bend up or down requires additional justification, which also requires calculations of the change in land work and the number of supports (underground and above-ground).

As seen from the results of modeling in Ansys, the most dangerous section is located on an elastically curved section along the convex generatrix of the pipe experiencing maximum tensile stresses.

Based on the strength condition with the accepted double safety factor to ensure a wall thickness of 14 mm, it is necessary to reduce the stress by 219 MPa. This can be achieved by limiting the installation temperature (to reasonable values) or installing compensators (not more than 10% of the total length).

Tables 10 and 11 show the results of similar calculations when the pipe line is closed at negative temperatures during winter in -43°C (design temperature difference 117°C).

Table 10: Preliminary calculation of wall thickness of straight section 0-20 km (mounting temperature -43°C)

	Wall thickness, mm						
Stresses	3	5	6	8	10	12	14
Axial, MPa	405,25	355,47	343,03	327,47	318,14	311,91	307,47
Annular, MPa	262,7	148,84	120,42	84,94	63,72	49,63	39,62

Table 11: Refined calculation of wall thickness of elastically bent section 0-20 km (mounting temperature -43°C)

Stresses	Wall thickness, mm						
Elastic bend radius, $500D_o$	3	5	6	8	10	12	14
Maximum bending stress, MPa	605,25	555,47	543,03	527,47	518,14	511,91	507,47
	Wall thickness, mm						
Elastic bend radius, $1000D_o$	3	5	6	8	10	12	14
Maximum bending stress, MPa	505,25	455,47	443,03	427,47	418,14	411,91	407,47
	Wall thickness, mm						
Elastic bend radius, $1500D_o$	3	5	6	8	10	12	14
Maximum bending stress, MPa	471,92	422,14	409,69	394,14	384,80	378,58	374,13

As can be seen from the simulation data (Table 10, 11), the strength condition with a maximum wall thickness of 14 mm is provided only on rectilinear sections ($1500 D_o$ and

more), which will lead to an increase in capital costs due to more land work and additional installation of supports.

Thus, it is necessary to further reduce the installation temperature of the pipeline to -57°C with a design temperature difference of 103°C , or install a compensator.

Table 12: Preliminary calculation of wall thickness of rectilinear section 0-20 km (mounting temperature -57°C)

Stresses	Wall thickness, mm						
	3	5	6	8	10	12	14
Axial, MPa	371,65	321,87	309,43	293,87	284,54	278,31	273,87
Annular, MPa	262,7	148,84	120,42	84,94	63,72	49,63	39,62

Table 13: Refined calculation of wall thickness of elastically bent section 0-20 km (mounting temperature -57°C)

Stresses	Wall thickness, mm						
	3	5	6	8	10	12	14
Elastic bend radius, 500Do	3	5	6	8	10	12	14
Maximum bending stress, MPa	571,65	521,87	509,43	493,87	484,54	478,31	473,87
Stresses	Wall thickness, mm						
	3	5	6	8	10	12	14
Elastic bend radius, 1000Do	3	5	6	8	10	12	14
Maximum bending stress, MPa	471,65	421,87	409,43	393,87	384,54	378,31	373,87
Stresses	Wall thickness, mm						
	3	5	6	8	10	12	14
Elastic bend radius, 1500Do	3	5	6	8	10	12	14
Maximum bending stress, MPa	438,32	388,54	376,09	360,54	351,2	344,98	340,53

Figure 31 shows the distribution of the longitudinal stresses on the elastically curved 0-20 km section obtained by the finite element method in Ansys for the case considered.

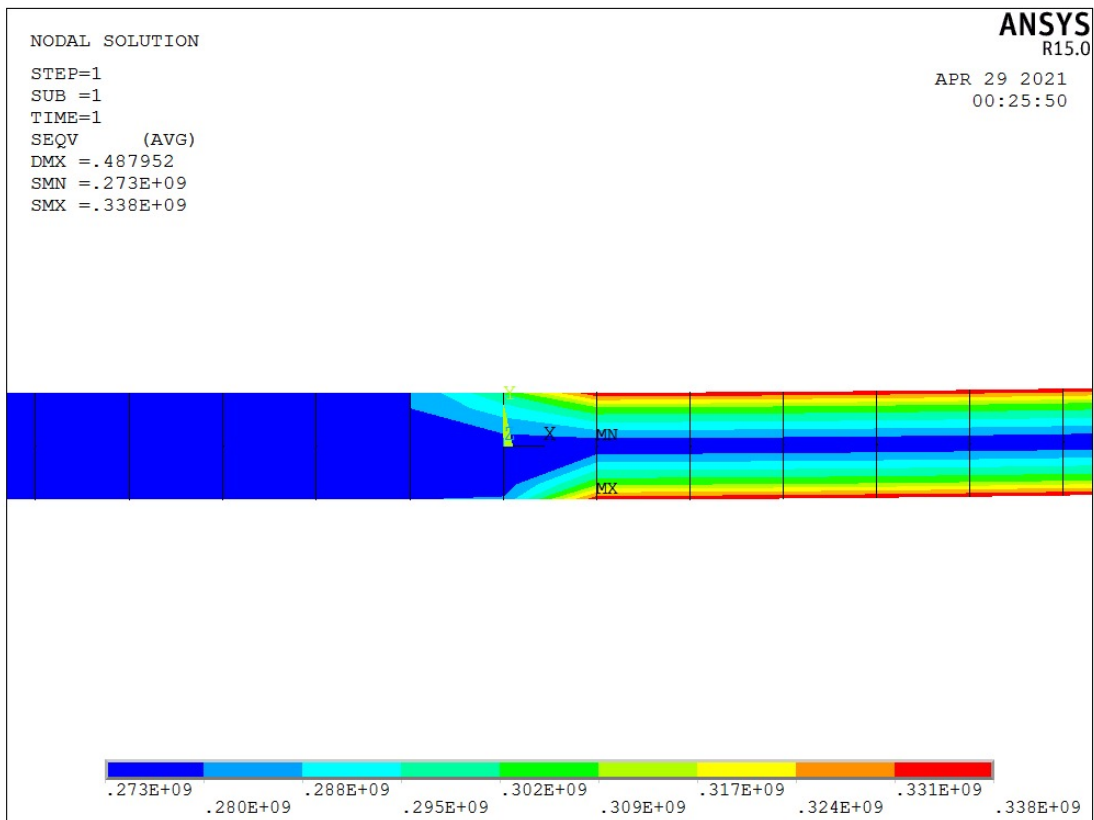
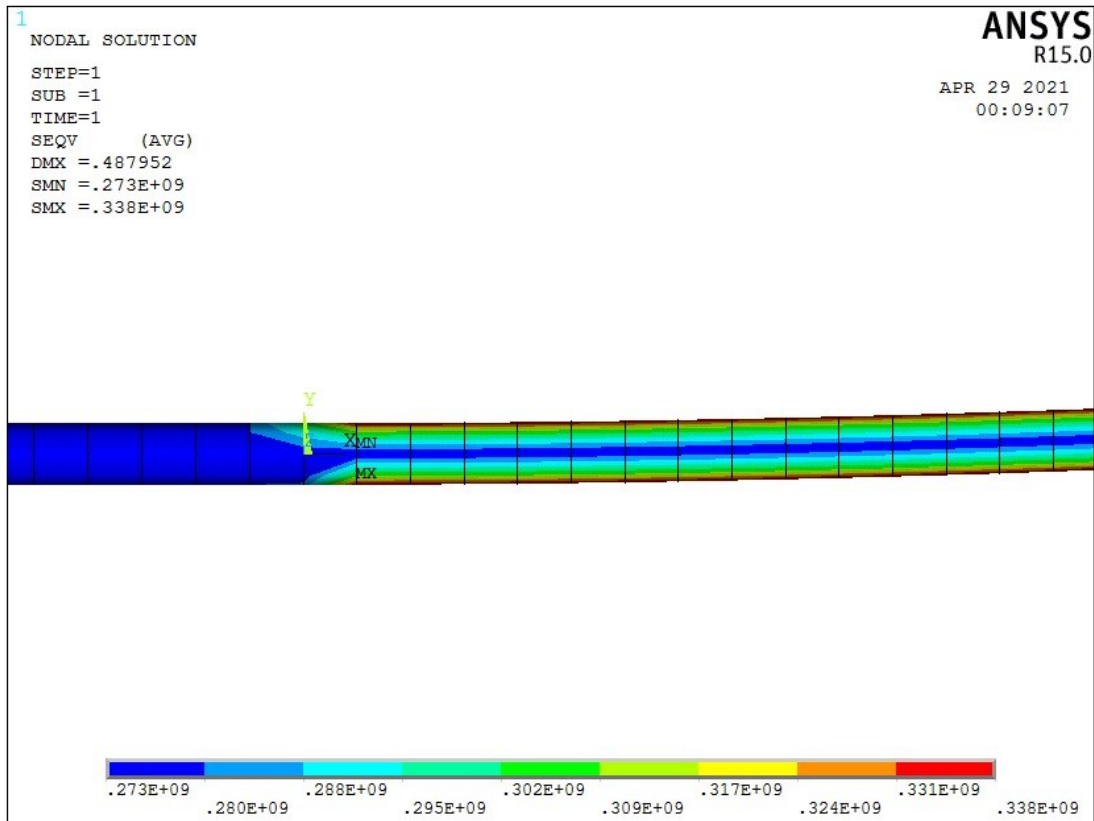

Figure 31: Distribution of longitudinal stresses on elastically bent section of pipeline

The visual stress distribution as in Figure 31 will be approximately the same for all subsequent accepted as permissible cases, since the purpose of this study was to determine the parameters under which the double safety factor of the pipeline is observed. Compliance with strength condition must be ≤ 350 MPa.

Figure 32 shows analytical dependencies of design solutions influence on stressed deformed state in 0-20 km section.

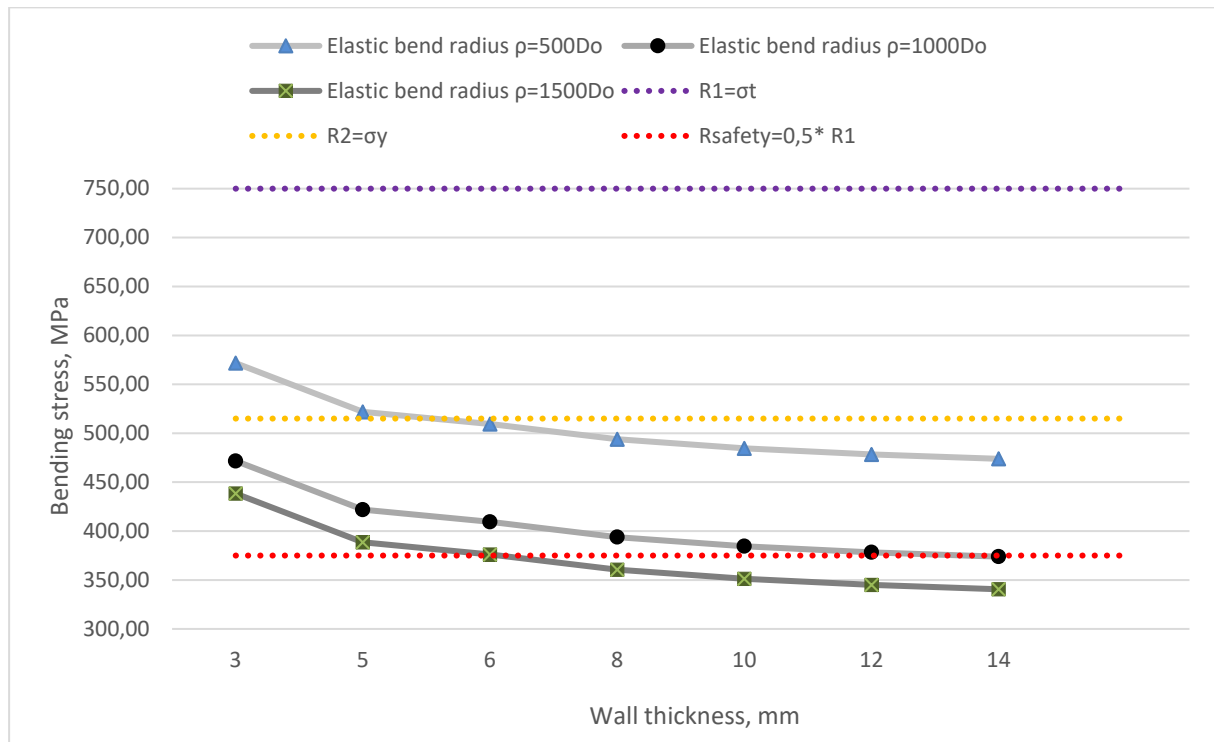

Figure 32: Analytical dependencies of design solutions influence on stressed deformed state in 0-20 km section

As can be seen from the data presented (Table 12, 13, Fig. 32), the reduction of the installation temperature to -57°C allows to ensure the condition of strength with a wall thickness of 14 mm and a radius of elastic bending of $1000 D_o$ (maximum longitudinal stresses are 373 MPa).

With a further increase in radius to $1500 D_o$, the wall thickness can be reduced to 8 mm, but such a solution, as noted earlier, requires additional justification for the calculation-based change in the amount of land work, the number and cost of supports necessary for fixing a straight section.

The installation temperatures of the last weld (-57°C and lower) used to reduce the wall thickness are not critical, since such temperatures can be provided in winter for a given area, it should be borne in mind that this temperature is necessary precisely when mounting the last weld, and therefore all other construction operations can be carried out regardless of temperature.

However, for this particular case, the resulting temperature is still too low, since it can be reached 1 times in several years. In this regard, a combination of both solutions is proposed for this area - limiting the installation temperature to -43°C and installing compensators, the total length of which in this case is reduced.

20-40 km ($P=13,1\text{ MPa}$, $T_{\text{LAPG}}=-143$)

The results of simulation of the stressed deformed state of the wall under the influence of design loads (pressure, temperature difference and elastic bending) at the mounting temperature of the last mounting joint in 24.5°C (design temperature difference 167.5°C) are presented in Tables 14 and 15.

Table 14: Preliminary calculation of wall thickness of rectilinear section 20-40 km (mounting temperature 24.5°C)

Stresses	Wall thickness, mm						
	3	5	6	8	10	12	14
Axial, MPa	526,45	476,67	464,23	448,67	439,34	433,11	428,67
Annular, MPa	248,9	149,34	124,45	93,34	74,67	62,23	53,34

Results of refined calculation of wall thickness of elastically bent section 20-40 km are given in Table 2

Table 15: Refined calculation of wall thickness of elastically bent section 20-40 km (mounting temperature 24.5°C)

Stresses	Wall thickness, mm						
	3	5	6	8	10	12	14
Elastic bend radius, $500D_o$							
Maximum bending stress, MPa	726,45	676,97	664,225	648,6688	639,335	633,1125	628,6679
	Wall thickness, mm						
Elastic bend radius, $1000D_o$							
Maximum bending stress, MPa	626,45	576,67	564,225	548,6688	539,335	533,1125	528,6679
	Wall thickness, mm						
Elastic bend radius, $1500D_o$							
Maximum bending stress, MPa	593,12	543,34	530,89	515,34	506	499,78	495,33

As can be seen from the presented calculations, the required wall thicknesses exceed the maximum possible in the variety, the elastic bend $1000D_o$ being the most optimal, since its increase in the larger direction is slightly reflected in the total bending stresses.

Based on the strength condition with the accepted double safety factor to ensure a wall thickness of 14 mm, it is necessary to reduce stresses by 178 MPa. This can be achieved by limiting the installation temperature (to reasonable values) or installing compensators (not more than 10% of the total length).

Tables 16 and 17 show the results of similar calculations when the pipe line is closed at negative temperatures during winter in -26°C . (design temperature difference 117°C)

Table 16: Preliminary calculation of wall thickness of rectilinear section 20-40 km (mounting temperature -26°C)

	Wall thickness, mm						
Stresses	3	5	6	8	10	12	14
Axial, MPa	405,25	355,47	343,03	327,47	318,14	311,91	307,47
Annular, MPa	248,9	149,34	124,45	93,34	74,67	32,23	53,34

Table 17: Refined calculation of wall thickness of elastically bent section 20-40 km (mounting temperature -26°C)

Stresses	Wall thickness, mm						
Elastic bend radius, $500D_o$	3	5	6	8	10	12	14
Maximum bending stress, MPa	605,25	555,47	543,03	527,47	518,14	511,91	507,47
	Wall thickness, mm						
Elastic bend radius, $1000D_o$	3	5	6	8	10	12	14
Maximum bending stress, MPa	505,25	455,47	443,03	427,47	418,14	411,91	407,47
	Wall thickness, mm						
Elastic bend radius, $1500D_o$	3	5	6	8	10	12	14
Maximum bending stress, MPa	471,92	422,14	409,69	394,14	384,80	378,58	374,13

As can be seen from the calculations, when the elastic bending radius is reduced to $1500D_o$, it is possible to provide a strength condition with a wall thickness of 14 mm and a closing temperature of -26°C , which will require the installation of additional supports to maintain the straightness of the section.

As can be seen from the simulation data (Table 16, 17), the strength condition with a maximum wall thickness of 14 mm is provided only on rectilinear sections ($1500D_o$ and more), which will lead to an increase in capital costs due to more land work and additional installation of supports.

Thus, it is necessary to further reduce the installation temperature of the pipeline to -40°C and the design temperature difference of 103°C , or install a compensator.

Table 18: Preliminary calculation of wall thickness of rectilinear section 20-40 km (mounting temperature -40°C)

Stresses	Wall thickness, mm						
	3	5	6	8	10	12	14
Axial, MPa	371,65	321,87	309,43	293,87	284,54	278,31	273,87
Annular, MPa	248,9	149,34	124,45	93,34	74,67	62,23	53,34

Table 19: Refined calculation of wall thickness of elastically bent section 20-40 km (mounting temperature -40°C)

Stresses	Wall thickness, mm						
Elastic bend radius, 500Do	3	5	6	8	10	12	14
Maximum bending stress, MPa	571,65	521,87	509,43	493,87	484,54	478,31	473,87
	Wall thickness, mm						
Elastic bend radius, 1000Do	3	5	6	8	10	12	14
Maximum bending stress, MPa	471,65	421,87	409,43	393,87	384,54	378,31	373,87
	Wall thickness, mm						
Elastic bend radius, 1500Do	3	5	6	8	10	12	14
Maximum bending stress, MPa	438,32	388,54	376,09	360,54	351,2	344,98	340,53

Figure 33 shows analytical dependencies of design solutions influence on stressed strain state in 20-40 km area

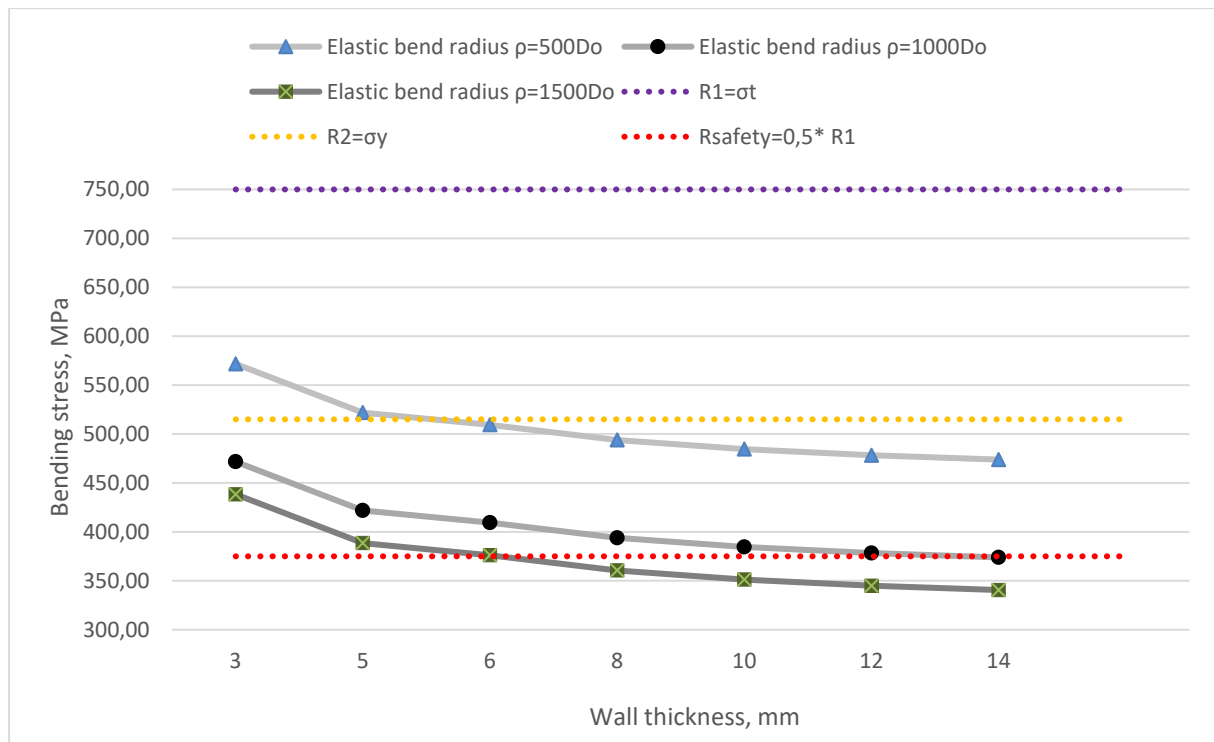

Figure 33: Analytical dependencies of design solutions influence on stressed strain state in 20-40 km section

As can be seen from the presented data (Table 18, 19, Fig. 33), the reduction of the installation temperature to -40°C allows to ensure the condition of strength with a wall thickness of 14 mm and a radius of elastic bending of $1000 D_o$ (maximum longitudinal stresses are 373 MPa). By further increasing the radius to $1500 D_o$, the wall thickness can be reduced to 8 mm.

The mounting temperatures of the last weld (-40°C and below) used to reduce the wall thickness are not critical, since such temperatures can be provided in winter for a given area.

40-60 km ($P=11,5 \text{ MPa}$, $T_{LAPG}=-129$)

Results of simulation of stressed deformed state of wall under action of design loads (pressure, temperature difference and elastic bending) at closing temperature of the last mounting joint in 24.5°C (design temperature difference 153.5°C) are presented in Tables 20 and 21.

Table 20: Preliminary calculation of wall thickness of rectilinear section 40-60 km (mounting temperature 24.5°C)

	Wall thickness, mm						
Stresses	3	5	6	8	10	12	14
Axial, MPa	477,65	433,95	423,03	409,37	401,18	395,71	391,81
Annular, MPa	218,5	131,1	109,25	81,94	65,55	54,63	46,82

Results of refined calculation of wall thickness of elastically bent section 40-60 km are given in Table 21.

Table 21: Refined calculation of wall thickness of elastically bent section 40-60 km (mounting temperature 24.5 ° C)

Stresses	Wall thickness, mm						
Elastic bend radius, 500D _o	3	5	6	8	10	12	14
Maximum bending stress, MPa	677,65	633,95	623,025	609,3688	601,175	595,7125	591,8107
	Wall thickness, mm						
Elastic bend radius, 1000D _o	3	5	6	8	10	12	14
Maximum bending stress, MPa	577,65	533,95	523,025	509,3688	501,175	495,7125	491,8107
	Wall thickness, mm						
Elastic bend radius, 1500D _o	3	5	6	8	10	12	14
Maximum bending stress, MPa	544,32	500,62	489,69	476,04	467,84	462,38	458,48

As can be seen from the presented calculations, the required wall thicknesses exceed the maximum possible in the variety, the elastic bend 1000 D_o being the most optimal, since its increase in the larger direction is slightly reflected in the total bending stresses.

Based on the strength condition with the accepted double safety factor to ensure a wall thickness of 14 mm, it is necessary to reduce stresses by 141 MPa. This can be achieved by limiting the installation temperature (to reasonable values) or installing compensators (not more than 10% of the total length).

Tables 22 and 23 show the results of similar calculations when the pipe line is closed at negative temperatures during winter in -10.5°C. (design temperature difference 118.5°C)

Table 22: Preliminary calculation of wall thickness of rectilinear section 40-60 km (mounting temperature -10.5°C)

	Wall thickness, mm						
Stresses	3	5	6	8	10	12	14
Axial, MPa	393,65	349,95	339,03	325,37	317,18	311,71	307,81
Annular, MPa	218,5	131,1	109,25	81,94	65,55	54,63	46,82

Table 23: Refined calculation of wall thickness of elastically bent section 40-60 km (mounting temperature -10.5°C)

Stresses	Wall thickness, mm						
Elastic bend radius, $500D_o$	3	5	6	8	10	12	14
Maximum bending stress, MPa	593,65	549,95	539,03	525,37	517,18	511,71	507,81
	Wall thickness, mm						
Elastic bend radius, $1000D_o$	3	5	6	8	10	12	14
Maximum bending stress, MPa	439,65	449,95	439,03	425,37	417,18	411,71	407,81
	Wall thickness, mm						
Elastic bend radius, $1500D_o$	3	5	6	8	10	12	14
Maximum bending stress, MPa	460,32	416,62	405,69	392,04	383,84	378,38	374,48

As can be seen from the calculations, when the radius of elastic bending is reduced to $1500 D_o$, it is possible to provide a strength condition with a wall thickness of 14 mm and a closing temperature of -10.5°C , which will require the installation of additional supports to maintain the straightness of the section.

As can be seen from the simulation data (Table 22, 23), the strength condition with a maximum wall thickness of 14 mm is provided only on rectilinear sections ($1500 D_o$ and more), which will lead to an increase in capital costs due to more land work and additional installation of supports.

Thus, it is necessary to further reduce the installation temperature of the pipeline to -25°C and the design temperature difference of 104°C , or install a compensator.

Table 24: Preliminary calculation of wall thickness of rectilinear section 40-60 km (mounting temperature -25°C)

	Wall thickness, mm						
Stresses	3	5	6	8	10	12	14
Axial, MPa	358,85	315,15	304,23	290,57	282,38	276,91	273,01
Annular, MPa	218,5	131,1	109,25	81,94	65,55	54,63	46,82

Table 25: Refined calculation of wall thickness of elastically bent section 40-60 km (mounting temperature -25°C)

Stresses	Wall thickness, mm						
Elastic bend radius, 500Do	3	5	6	8	10	12	14
Maximum bending stress, MPa	558,85	515,15	504,23	490,57	482,38	476,91	473,01
	Wall thickness, mm						
Elastic bend radius, 1000Do	3	5	6	8	10	12	14
Maximum bending stress, MPa	458.85	415.15	404.23	390.57	382.38	376.91	373.01
	Wall thickness, mm						
Elastic bend radius, 1500Do	3	5	6	8	10	12	14
Maximum bending stress, MPa	425.52	381.82	370.89	357.24	349.04	343.58	339.68

Figure 34 shows analytical dependencies of design solutions influence on stressed strain state in 40-60 km area

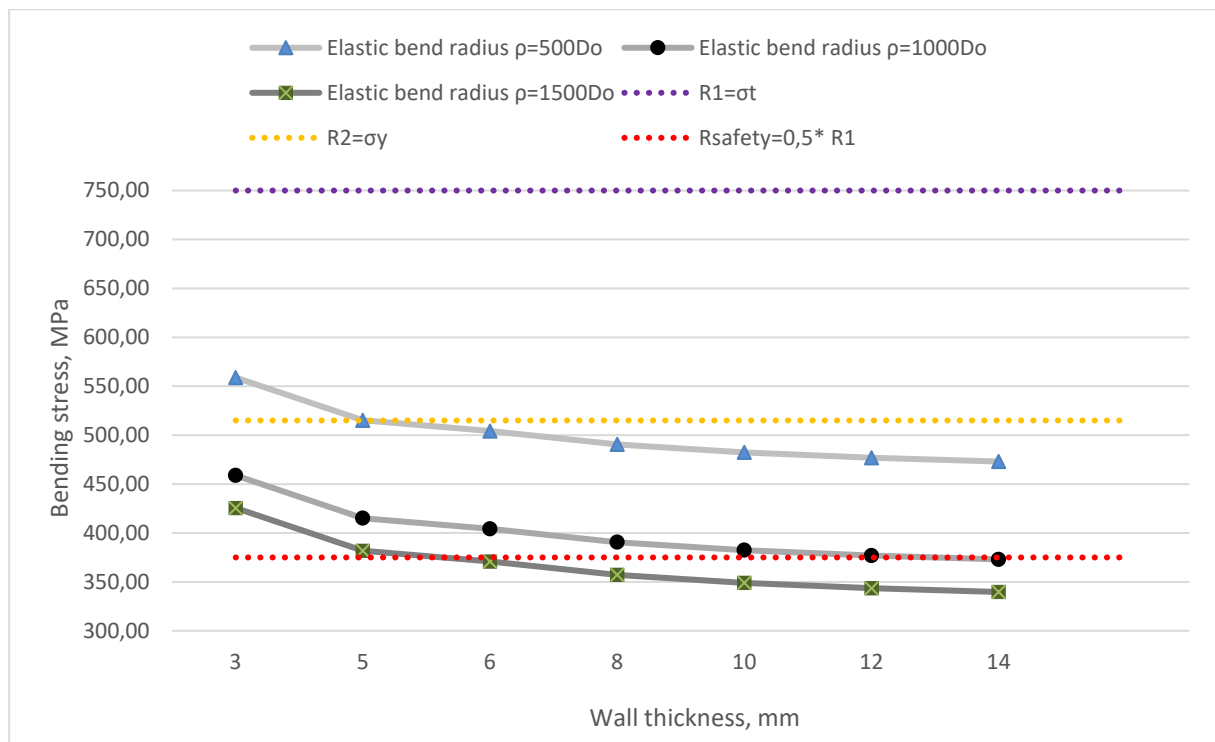

Figure 34: Analytical dependencies of design solutions influence on stressed deformed state in 40-60 km area

As can be seen from the presented data (Table 24, 25, Fig. 34), the reduction of the installation temperature to -25°C allows to ensure the condition of strength with a wall

thickness of 14 mm and a radius of elastic bending of $1000 D_o$ (maximum longitudinal stresses are 373 MPa). With a further increase in radius to $1500 D_o$, the wall thickness can be reduced to 6 mm.

The mounting temperatures of the last weld (-25°C and below) used to reduce wall thickness are achievable, since such temperatures can be provided in winter for a given area.

60-80 km ($P=9,8$ MPa, $T_{LAPG}=-117$)

Results of simulation of stressed deformed state of wall under action of design loads (pressure, temperature difference and elastic bending) at closing temperature of the last mounting joint in 24.5°C (design temperature difference 141.5°C) are presented in Tables 26 and 27.

Table 26: Preliminary calculation of wall thickness of straight section 60-80 km (mounting temperature 24.5°C)

	Wall thickness, mm						
Stresses	3	5	6	8	10	12	14
Axial, MPa	432,7	395,46	386,15	374,51	367,53	362,88	359,55
Annular, MPa	186,2	111,72	39,1	69,83	55,86	46,55	39,9

Results of refined calculation of wall thickness of elastically bent section 60-80 km are given in Table 27.

Table 27: Refined calculation of wall thickness of elastically bent section 60-80 km (mounting temperature 24.5°C)

Stresses	Wall thickness, mm						
Elastic bend radius, $500D_o$	3	5	6	8	10	12	14
Maximum bending stress, MPa	632,7	595,46	586,15	574,5125	567,53	562,875	559,55
	Wall thickness, mm						
Elastic bend radius, $1000D_o$	3	5	6	8	10	12	14
Maximum bending stress, MPa	532,7	495,46	486,15	474,5125	467,53	462,875	459,55
	Wall thickness, mm						
Elastic bend radius, $1500D_o$	3	5	6	8	10	12	14
Maximum bending stress, MPa	499,37	462,13	452,82	441,18	434,2	429,54	426,22

As can be seen from the presented calculations, the required wall thicknesses exceed the maximum possible in the variety, the elastic bend $1000 D_o$ being the most optimal, since its increase in the larger direction is slightly reflected in the total bending stresses.

Based on the strength condition with the accepted double safety margin to ensure a wall thickness of 14 mm, it is necessary to reduce stresses by 109.55 MPa. This can be achieved by limiting the installation temperature (to reasonable values) or installing compensators (not more than 10% of the total length).

Tables 28 and 29 show the results of similar calculations when the pipe line is mounted at negative temperatures during a warm period of 3°C . (design temperature difference 120°C)

Table 28: Preliminary calculation of wall thickness of straight section 60-80 km (mounting temperature 3°C)

	Wall thickness, mm						
Stresses	3	5	6	8	10	12	14
Axial, MPa	381,1	343,86	334,55	322,91	315,93	311,28	307,95
Annular, MPa	186,2	111,72	93,1	69,83	55,86	46,55	39,9

Table 29: Refined calculation of wall thickness of elastically bent section 60-80 km (installation temperature 3°C)

Stresses	Wall thickness, mm						
Elastic bend radius, $500D_o$	3	5	6	8	10	12	14
Maximum bending stress, MPa	581,1	543,86	534,55	522,91	515,93	511,28	507,95
	Wall thickness, mm						
Elastic bend radius, $1000D_o$	3	5	6	8	10	12	14
Maximum bending stress, MPa	481,1	443,86	434,55	422,91	415,93	411,28	407,95
	Wall thickness, mm						
Elastic bend radius, $1500D_o$	3	5	6	8	10	12	14
Maximum bending stress, MPa	447,77	410,53	401,22	389,58	382,60	377,94	374,62

As can be seen from the calculations, when the elastic bending radius is reduced to $1500 D_o$, it is possible to provide a strength condition with a wall thickness of 14 mm and a closing temperature of 3°C , which will require the installation of additional supports to maintain the straightness of the section.

As can be seen from the simulation data (Table 28, 29), the strength condition with a maximum wall thickness of 14 mm is provided only on rectilinear sections ($1500D_o$ and more), which will lead to an increase in capital costs due to more land work and additional installation of supports.

Thus, it is necessary to further reduce the installation temperature of the pipeline to -11°C and the design temperature difference of 106°C , or install a compensator.

Table 30: Preliminary calculation of wall thickness of straight section 60-80 km (mounting temperature -11°C)

Stresses	Wall thickness, mm						
	3	5	6	8	10	12	14
Axial, MPa	347,5	310,26	300,95	289,31	282,33	277,68	274,35
Annular, MPa	186,2	111,72	93,1	69,83	55,86	46,55	39,9

Table 31: Refined calculation of wall thickness of elastically bent section 60-80 km (mounting temperature -11°C)

Stresses	Wall thickness, mm						
Elastic bend radius, $500D_o$	3	5	6	8	10	12	14
Maximum bending stress, MPa	547,5	510,26	500,95	489,31	482,33	477,68	474,35
	Wall thickness, mm						
Elastic bend radius, $1000D_o$	3	5	6	8	10	12	14
Maximum bending stress, MPa	447,5	410,26	400,95	389,31	382,33	377,68	374,35
	Wall thickness, mm						
Elastic bend radius, $1500D_o$	3	5	6	8	10	12	14
Maximum bending stress, MPa	414,17	376,93	367,62	355,98	349	344,34	341,02

Figure 35 shows analytical dependencies of design solutions influence on stressed strain state in 60-80 km area.

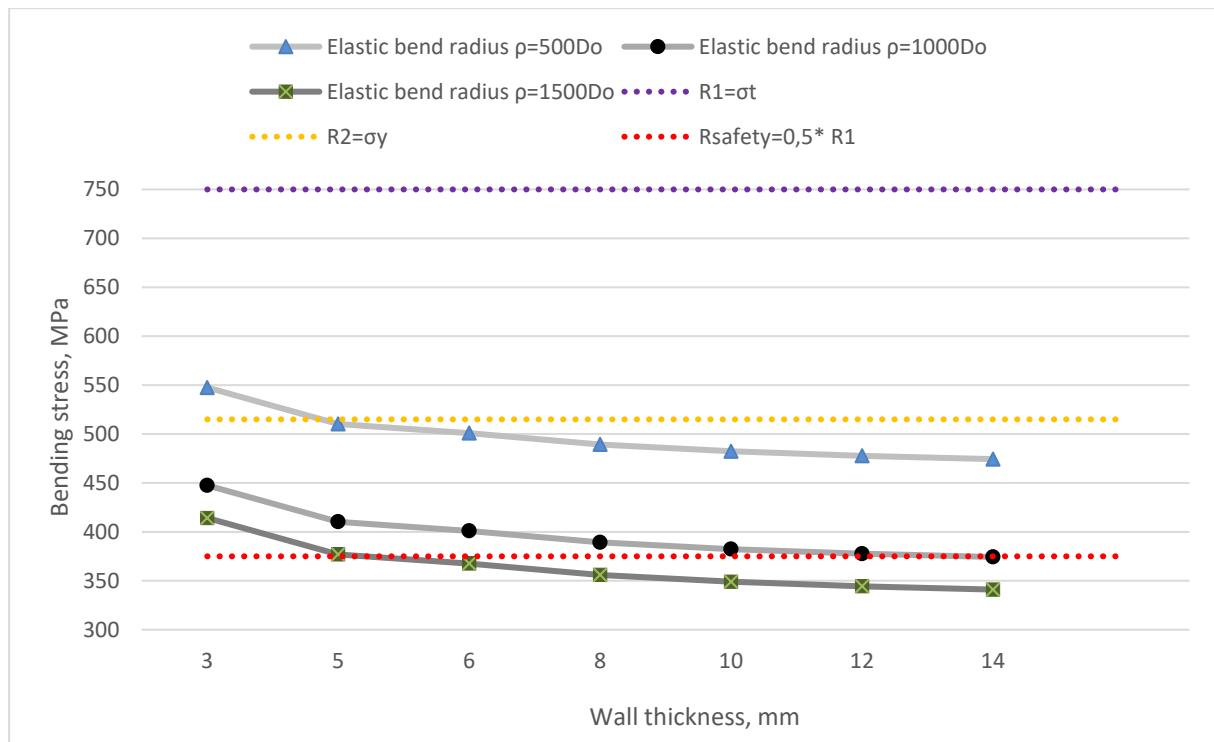

Figure 35: Analytical dependencies of design solutions influence on stressed strain state in 60-80 km section

As can be seen from the presented data (Table 30, 31, Fig. 35), the reduction of the installation temperature to -11°C allows to ensure the condition of strength with a wall thickness of 14 mm and a radius of elastic bending of $1000 D_o$ (maximum longitudinal stresses are 374.35 MPa). With a further increase in radius to $1500 D_o$, the wall thickness can be reduced to 6 mm.

The mounting temperatures of the last weld (-11°C and below) used to reduce wall thickness are achievable, since such temperatures can be provided in winter for a given area.

80-100 km ($P=7,9 \text{ MPa}$, $T_{LAPG}=-107$)

Results of modeling of tensely deformed condition of a wall under the influence of design loadings (pressure, temperature difference and an elastic bend) at a temperature of short circuit of the last assembly joint in 24.5°C (settlement temperature difference of 131.5°C) are presented in tables 32 and 33.

Table 32: Preliminary calculation of wall thickness of rectilinear section 80-100 km (mounting temperature 24.5°C)

	Wall thickness, mm						
Stresses	3	5	6	8	10	12	14
Axial, MPa	390,65	360,63	353,13	343,74	338,12	334,36	331,68
Annular, MPa	150,1	90,06	75,05	56,29	45,03	37,53	32,16

Results of refined calculation of wall thickness of elastically bent section 80-100 km are given in Table 33.

Table 33: Refined calculation of wall thickness of elastically bent section 80-100 km (mounting temperature 24.5°C)

Stresses	Wall thickness, mm						
	3	5	6	8	10	12	14
Elastic bend radius, 500D _o							
Maximum bending stress, MPa	590,65	560,63	553,13	543,74	538,12	534,36	531,68
	Wall thickness, mm						
Elastic bend radius, 1000D _o	3	5	6	8	10	12	14
Maximum bending stress, MPa	490,65	460,63	453,13	443,74	438,12	434,36	431,68
	Wall thickness, mm						
Elastic bend radius, 1500D _o	3	5	6	8	10	12	14
Maximum bending stress, MPa	457,32	427,3	419,79	410,,41	404,78	401,03	398,35

As can be seen from the presented calculations, the required wall thicknesses exceed the maximum possible in the variety, the elastic bend 1000 D_o being the most optimal, since its increase in the larger direction is slightly reflected in the total bending stresses.

Based on the strength condition with the accepted double safety margin to ensure a wall thickness of 14 mm, it is necessary to reduce stresses by 81.68 MPa. This can be achieved by limiting the installation temperature (to reasonable values) or installing compensators (not more than 10% of the total length).

Tables 34 and 35 show the results of similar calculations when the pipe line is closed at negative temperatures during a warm period of 14.5°C. (design temperature difference 121.5°C)

Table 34: Preliminary calculation of wall thickness of rectilinear section 80-100 km (mounting temperature 14.5°C)

Stresses	Wall thickness, mm						
	3	5	6	8	10	12	14
Axial, MPa	366,65	336,63	329,13	319,74	314,12	310,36	307,68
Annular, MPa	150,1	90,06	75,05	56,29	45,03	37,53	32,16

Table 35: Refined calculation of wall thickness of elastically bent section 80-100 km (mounting temperature 14.5°C)

Stresses	Wall thickness, mm						
Elastic bend radius, 500D _o	3	5	6	8	10	12	14
Maximum bending stress, MPa	566,65	536,63	529,13	519,74	514,12	510,36	507,68
	Wall thickness, mm						
Elastic bend radius, 1000D _o	3	5	6	8	10	12	14
Maximum bending stress, MPa	466,65	436,63	429,13	419,74	414,12	410,36	407,68
	Wall thickness, mm						
Elastic bend radius, 1500D _o	3	5	6	8	10	12	14
Maximum bending stress, MPa	433,32	403,3	395,79	386,41	380,78	377,03	374,35

As can be seen from the calculations, when the elastic bending radius is reduced to 1500 D_o , it is possible to provide a strength condition with a wall thickness of 14 mm and a closing temperature of 14.5°C, which will require the installation of additional supports to maintain the straightness of the section.

As can be seen from the simulation data (Table 34, 35), the strength condition with a maximum wall thickness of 14 mm is provided only on rectilinear sections (1500 D_o and more), which will lead to an increase in capital costs due to more land work and additional installation of supports.

Thus, it is necessary to further reduce the installation temperature of the pipeline to 0°C and the design temperature difference of 107°C, or install a compensator.

Table 36: Preliminary calculation of wall thickness of rectilinear section 80-100 km (mounting temperature 0°C)

	Wall thickness, mm						
Stresses	3	5	6	8	10	12	14
Axial, MPa	331,85	301,83	294,33	284,94	279,32	275,56	272,88
Annular, MPa	150,1	90,06	75,05	56,29	45,03	37,53	32,16

Table 37: Refined calculation of wall thickness of elastically bent section 80-100 km (mounting temperature 0°C)

Stresses	Wall thickness, mm						
Elastic bend radius, 500Do	3	5	6	8	10	12	14
Maximum bending stress, MPa	531,85	501,83	494,33	484,94	479,32	475,56	472,88
	Wall thickness, mm						
Elastic bend radius, 1000Do	3	5	6	8	10	12	14
Maximum bending stress, MPa	431,85	401,83	394,33	384,94	379,32	375,56	372,88
	Wall thickness, mm						
Elastic bend radius, 1500Do	3	5	6	8	10	12	14
Maximum bending stress, MPa	398,52	368,5	360,99	351,61	345,98	342,23	339,55

Figure 36 shows analytical dependencies of design solutions influence on stressed strain state in 80-100 km area.

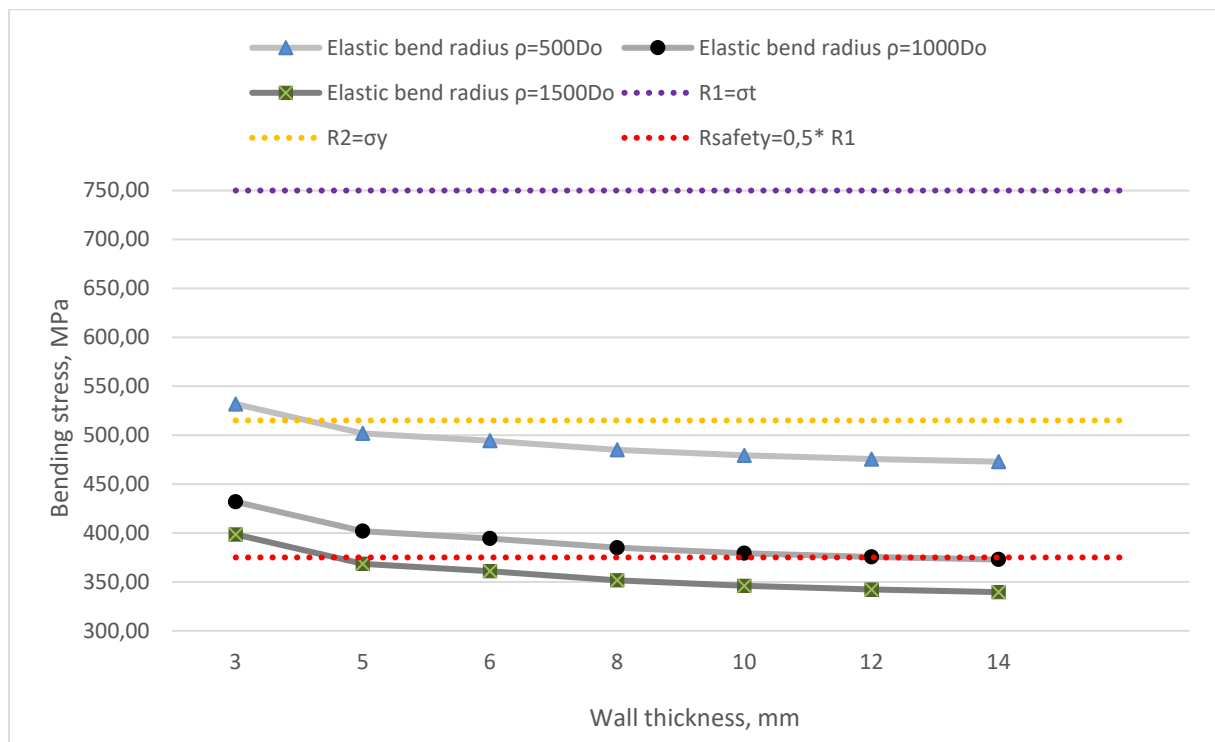

Figure 36: Analytical dependencies of design solutions influence on stressed strain state in 80-100 km section

As can be seen from the data presented (Table 36, 37, Figure 36), the reduction of the installation temperature to 0°C allows to ensure the condition of strength with a wall

thickness of 14 mm and a radius of elastic bending of $1000 D_o$ (maximum longitudinal stresses are 372.88 MPa). By further increasing the radius to $1500 D_o$, the wall thickness can be reduced to 5 mm.

The temperatures adopted to reduce the wall thickness of the last weld closure (0°C and below) are achievable and the pipeline construction work can be carried out at a relatively warm time of year.

100-120 km ($P=5,9$ MPa, $T_{LAPG}=-99$)

Results of simulation of stressed deformed state of wall under action of design loads (pressure, temperature difference and elastic bending) at closing temperature of the last mounting joint in 24.5°C (design temperature difference 123.5°C) are presented in Tables 38 and 39.

Table 38: Preliminary calculation of wall thickness of straight section 100-120 km (mounting temperature 24.5°C)

	Wall thickness, mm						
Stresses	3	5	6	8	10	12	14
Axial, MPa	348,07	325,67	320,08	313,11	308,93	306,16	304,19
Annular, MPa	103,33	58,55	47,36	33,41	25,06	19,52	15,58

Results of refined calculation of wall thickness of elastically bent section 100-120 km are given in Table 39.

Table 39: Refined calculation of wall thickness of elastically bent section 100-120 km (mounting temperature 24.5°C)

Stresses	Wall thickness, mm						
Elastic bend radius, $500D_o$	3	5	6	8	10	12	14
Maximum bending stress, MPa	548,07	525,67	520,08	513,11	508,39	506,16	504,19
	Wall thickness, mm						
Elastic bend radius, $1000D_o$	3	5	6	8	10	12	14
Maximum bending stress, MPa	448,07	425,67	420,08	413,11	408,93	406,16	404,19
	Wall thickness, mm						
Elastic bend radius, $1500D_o$	3	5	6	8	10	12	14
Maximum bending stress, MPa	414,74	392,34	386,75	379,78	375,6	372,83	370,86

As can be seen from the calculations, when the elastic bending radius is reduced to $1500 D_o$, it is possible to provide a strength condition with a wall thickness of 12 mm and a closing temperature of 24.5°C , which will require the installation of additional supports to maintain the straightness of the section.

As can be seen from the simulation data (Table 38, 39), the strength condition with a maximum wall thickness of 12 mm is provided only on rectilinear sections ($1500 D_o$ and more), which will lead to an increase in capital costs due to more land work and additional installation of supports.

Thus, it is necessary to further reduce the installation temperature of the pipeline to 12°C and the calculated temperature difference of 111°C , or install a compensator.

Table 40: Preliminary calculation of wall thickness of straight section 100-120 km (mounting temperature 12°C)

Stresses	Wall thickness, mm						
	3	5	6	8	10	12	14
Axial, MPa	318,07	295,67	290,08	283,11	278,93	276,16	274,19
Annular, MPa	103,33	58,55	47,36	33,41	25,06	19,52	15,58

Table 41: Refined calculation of wall thickness of elastically bent section 100-120 km (mounting temperature 12°C)

Stresses	Wall thickness, mm						
	3	5	6	8	10	12	14
Elastic bend radius, $500D_o$	3	5	6	8	10	12	14
Maximum bending stress, MPa	518,07	495,67	490,08	483,11	478,93	476,16	474,19
Stresses	Wall thickness, mm						
	3	5	6	8	10	12	14
Elastic bend radius, $1000D_o$	3	5	6	8	10	12	14
Maximum bending stress, MPa	418,07	395,67	390,08	383,11	378,93	376,16	374,19
Stresses	Wall thickness, mm						
	3	5	6	8	10	12	14
Elastic bend radius, $1500D_o$	3	5	6	8	10	12	14
Maximum bending stress, MPa	384,74	362,34	356,75	349,78	345,6	342,83	340,86

Figure 37 shows the analytical dependencies of the impact of design solutions on the stressed strain state of 100-120 km

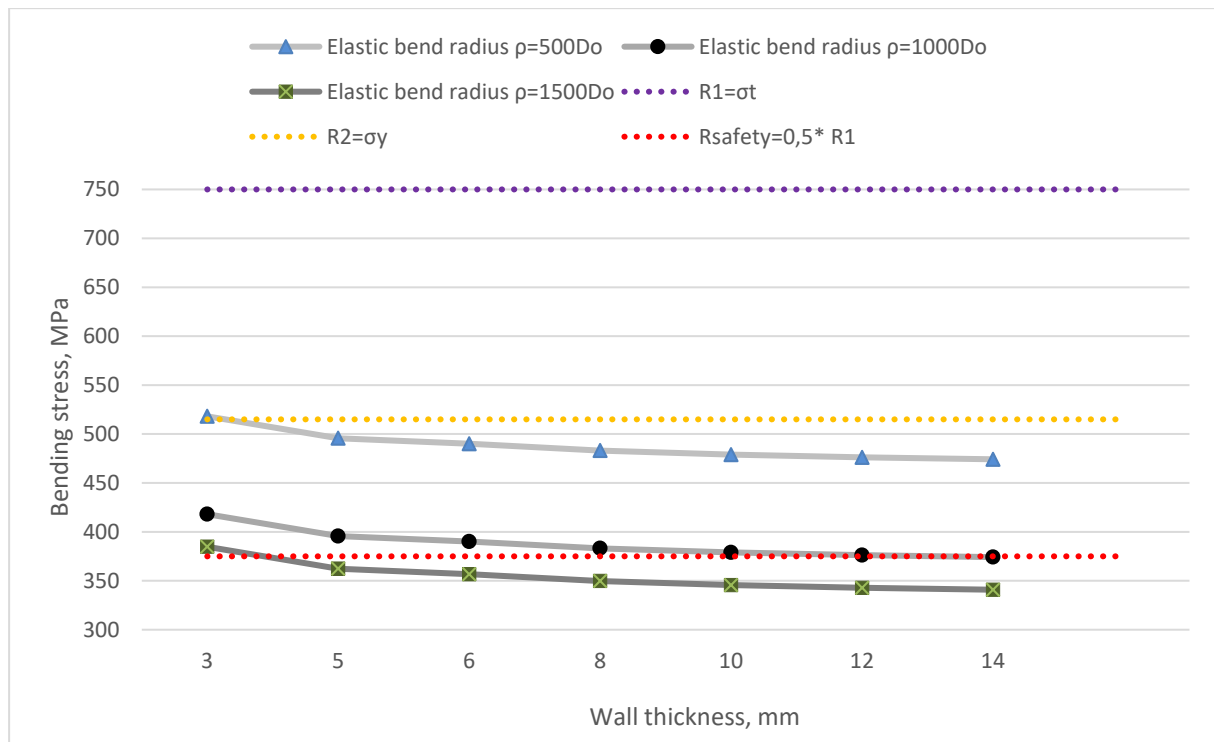

Figure 37: Analytical dependencies of design solutions influence on stressed strain state 100-120 km

As can be seen from the presented data (Table 40, 41 6, Figure 37), the reduction of the installation temperature to 12°C allows to ensure the condition of strength with a wall thickness of 14 mm and a radius of elastic bending of $1000 D_o$ (maximum longitudinal stresses are 374.19 MPa). By further increasing the radius to $1500 D_o$, the wall thickness can be reduced to 5 mm.

The temperatures adopted to reduce the wall thickness of the last weld closure (12°C and below) are achievable, and the pipeline construction work can be carried out at a relatively warm time of year.

The results of the calculations showed the possibility of ensuring strength at the given design loads at a wall thickness of 14 mm. At the same time, compensators can be used to compensate for temperature deformations (in sections 0-20), supports for accurate attachment at design elevations without bends (section 20-40), as well as limitation of the maximum closing temperature of the raft during installation (for section 0-20 km not more than -43°C, 20-40 km not more than -26°C, 40-60 km not more than -25°C, 60-80 km not more than -11°C, 80-100 km not more than 0°C, 100-120 km not more than 12°C).

4.2 Determination of compensation section parameters for section 0-20 km of cryogenic pipeline

As the above calculations showed, for the section 0-20 km, due to the strong temperature difference, it is necessary to install compensators, and therefore, in this section the compensator parameters are calculated. This section used analysis and modeling using the Ansys finite element analysis system.

In order to determine the optimal design solution during the construction of the above-ground compensating section of the cryogenic LAPG pipeline during the study, the criteria of high compensating capacity and reliability were adopted.

The main objective of this study is the application of high compensability in the above-ground area, that is, compensation of pipeline deformations from the effect of temperature difference and pressure. Also, ensure high design reliability by reducing maximum stresses in hazardous sections of the cryogenic LAPG pipeline.

During the construction of the above-ground pipeline, various compensation systems can be used, the conditional diagrams of which are shown in Figure 38.

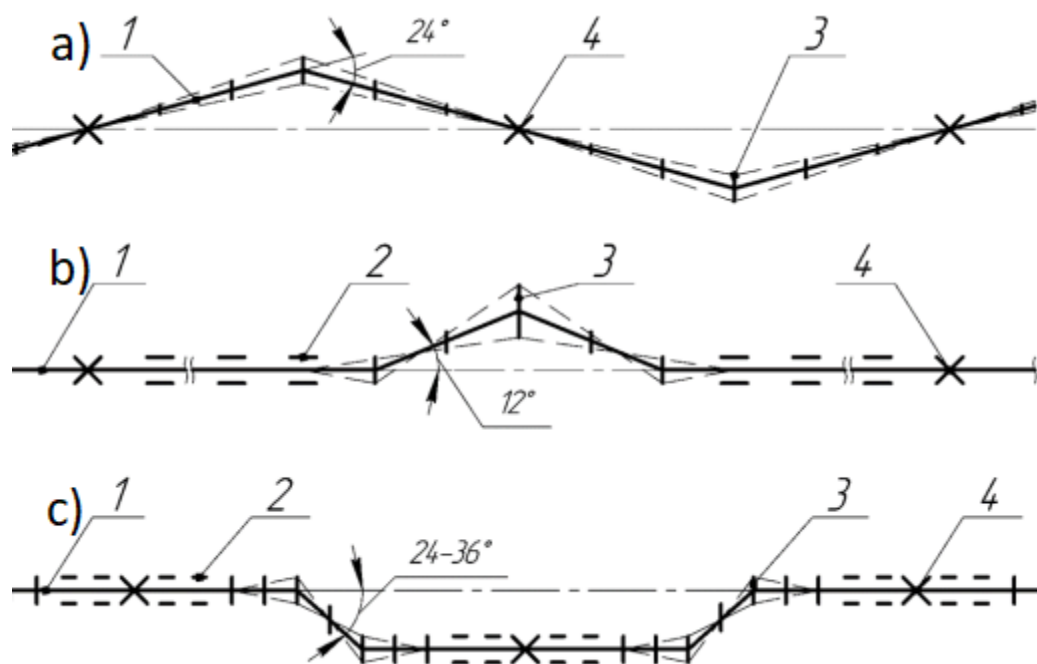

Figure 38: Compensation systems during construction of above-ground pipeline section⁷⁷

⁷⁷ Bykov, L., Besheryan, Z. 2019. Experimental studies of deformability and simulation of operation of above-ground pipelines on permafrost soils. Oil and Gas business, vol. 72, pp. 35-43.

Where, 1 – pipeline; 2 – longitudinally movable support; 3 – freely movable support; 4 – fixed support; a) Z-shaped laying; b) straight-line gasket with slightly bent compensating section; c) u shaped gasket.

According to the experience of construction of above-ground pipelines, the most effective compensating system is a straight-line gasket with a weak bend, since it better meets the conditions of reliability and compensating ability.⁷⁸

This weakly bent compensation system has been adopted to investigate optimal stress strain state parameters.

As the initial data for the calculation, the results of the stress strain study in the first section of the pipeline (0-20 km) and the main load parameters were taken, which are given in Table 42.

Table 42: Initial data for model creation in Ansys

D_o - outer diameter, mm	114,3
P - internal pressure, MPa	15
δ - wall thickness, mm	14
σ_{axial} - axial pressure, MPa	307,5

The numerical calculation of the slightly bent compensation section was made in accordance with the regulatory document used for main pipelines.⁷⁹

Longitudinal stresses from internal pressure:

$$1,1 \cdot \sigma_{axial} = 1,1 \cdot 307,5 = 338,25 \text{ MPa} \quad (\text{Eq. 24})$$

Axial moment of resistance:

$$W = \frac{2 \cdot I}{D_o} = 0,02224 = 22,24 \cdot 10^{-3} \text{ m}^3 \quad (\text{Eq. 25})$$

⁷⁸ Petrov, I., Spiridonov, V. 1973. Above ground piping. Moscow: Nedra.

⁷⁹ Set of Rules «SP» 36.13330-2012. Trunk pipelines.

Span between supports:

$$l = \sqrt{\frac{12W \cdot (R_2 - \sigma_{axial})}{q_{pipe}}} = \sqrt{\frac{12 \cdot 0,02224 \cdot (515 - 338,25)}{346,29}} = 11,67 \text{ m} \quad (\text{Eq. 26})$$

Pipe weight load:

$$q_{pipe} = \gamma_m \cdot \frac{\pi}{4} \cdot (D_o^2 - D_{in}^2) = 78500 \cdot \frac{\pi}{4} \cdot (0,1143^2 - 0,0863^2) = 346,29 \text{ N/m} \quad (\text{Eq. 27})$$

We accept $l = 12 \text{ m}$, then the length of the compensation section $L_{comp} = 4 \cdot l = 4 \cdot 12 = 48 \text{ m}$, since according to normative document⁸⁰, the length of the compensation section is selected equal to 4-6 values of the span distance between the supports.

Actual length of compensation section:

$$L_{comp.actual} = \frac{L_{comp}}{\cos \varphi} = \frac{48}{0,978} = 49 \text{ m} \quad (\text{Eq. 28})$$

Where is φ - the angle taken from the condition of passing the diagnostic device equal to 12° .

Pipe beam bend in middle of section:

$$f = 0,5 \cdot L_{comp} \cdot \text{tg} \varphi = 0,5 \cdot 49 \cdot \text{tg} 12 = 5,2 \text{ m} \quad (\text{Eq. 29})$$

⁸⁰ Set of Rules «SP» 36.13330-2012. Trunk pipelines.

Distance between fixed supports:

$$L_{estimated} = \frac{\left[R_2 - \frac{l^2}{12 \cdot W} - P \cdot \left(\frac{D_o}{4 \cdot \delta} - 0,5 \right) \right] \cdot L_{comp} \cdot f}{6 \cdot \cos \varphi \cdot I \cdot \left[\alpha_T \cdot E \cdot \Delta T + P \cdot \left(\frac{D_o}{10 \cdot \delta} - 0,2 \right) \cdot \left(\frac{1}{W} - \frac{2}{F \cdot f} \right) \right]} \quad (\text{Eq. 30})$$

$$= \frac{\left[515 - \frac{12^2}{12 \cdot 0,02224} - 15 \cdot \left(\frac{0,1143}{4 \cdot 0,014} - 0,5 \right) \right]}{6 \cdot 0,978 \cdot 0,001271 \cdot \left[1,2 \cdot 10^{-5} \cdot 2,1 \cdot 10^5 \cdot 117 + 15 \cdot \left(\frac{0,1143}{10 \cdot 0,014} - 0,2 \right) \right]} \cdot \frac{48 \cdot 5,2}{\left(\frac{1}{0,02224} - \frac{2}{0,0044 \cdot 5,2} \right)} = 123,63 \text{ m}$$

Round $L_{estimated}$ to a multiple of 2*1: $\frac{L_{estimated}}{2 \cdot l} = \frac{123,63}{2 \cdot 12} = 5,15 \text{ m}$ which corresponds to 10 spans.

Design diagram of straight line pipeline with slightly bent compensation section is shown in Figure 39.

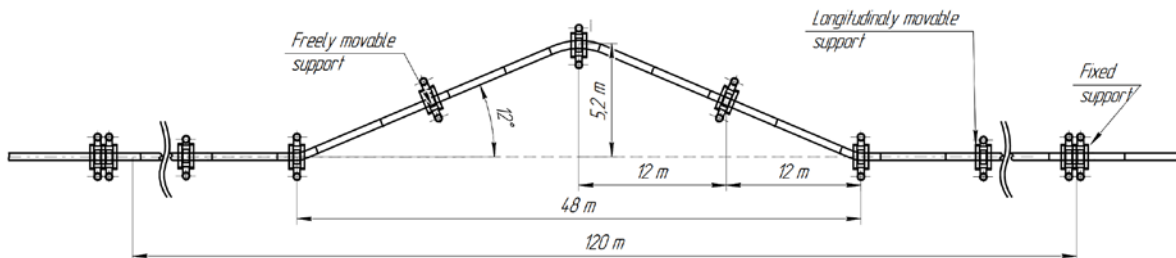

Figure 39: Compensation section design diagram

A finite element evaluation was performed to verify the strength and reliability condition with the following geometric parameters of a straight line pipeline with a slightly bent compensation section as shown in Table 43.

Table 43: Geometrical characteristics of the compensating section

L - length of the whole compensating section between fixed supports, m	120
L_{comp} - compensating section length, m	48
φ - angle between straight and inclined section of compensator	12°

According to the obtained results, using the finite element analysis, data on transverse movements and maximum deformations arising in hazardous sections of the compensation section were obtained, which are shown in Figure 40.

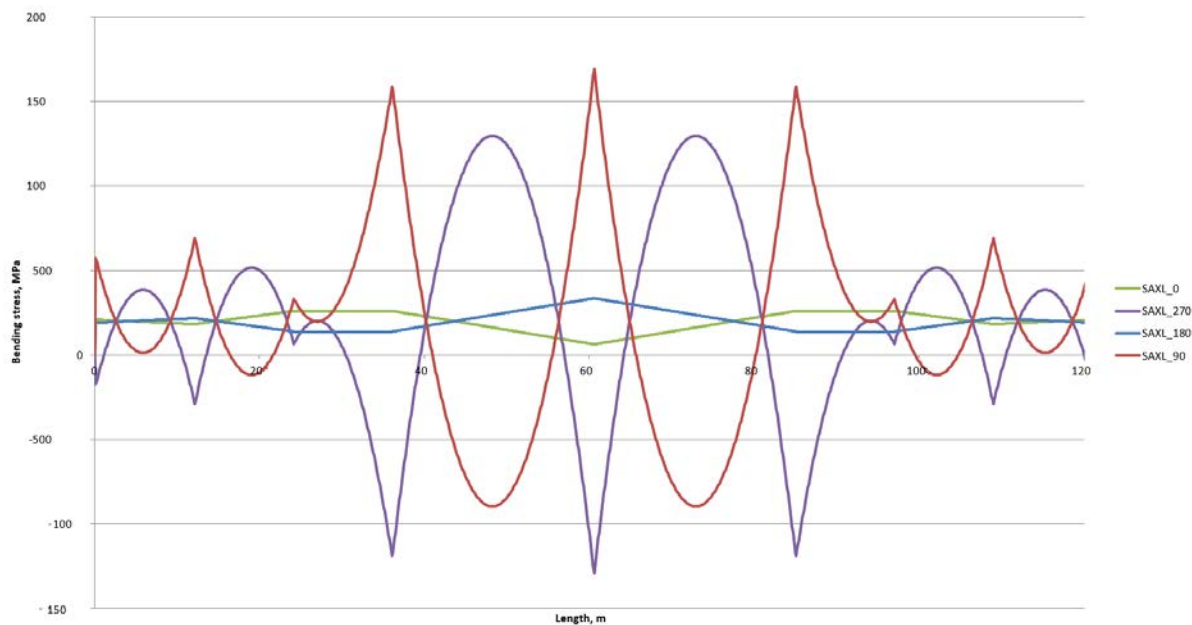

Figure 40: Dependency distribution of stresses occurring in the compensating section

Where, SAXL_0, SAXL_270, SAXL_180, SAXL_90 are longitudinal stresses.

SAXL_0 and SAXL_180 - longitudinal stresses arising from the action of the internal pressure of the pumped product (15 MPa) and the temperature difference (-43°C);

SAXL_270 and SAXL_90 - stresses arising from the weight of the pipeline.

Figure 41 shows the distribution of equivalent stresses along the length of the compensating section.

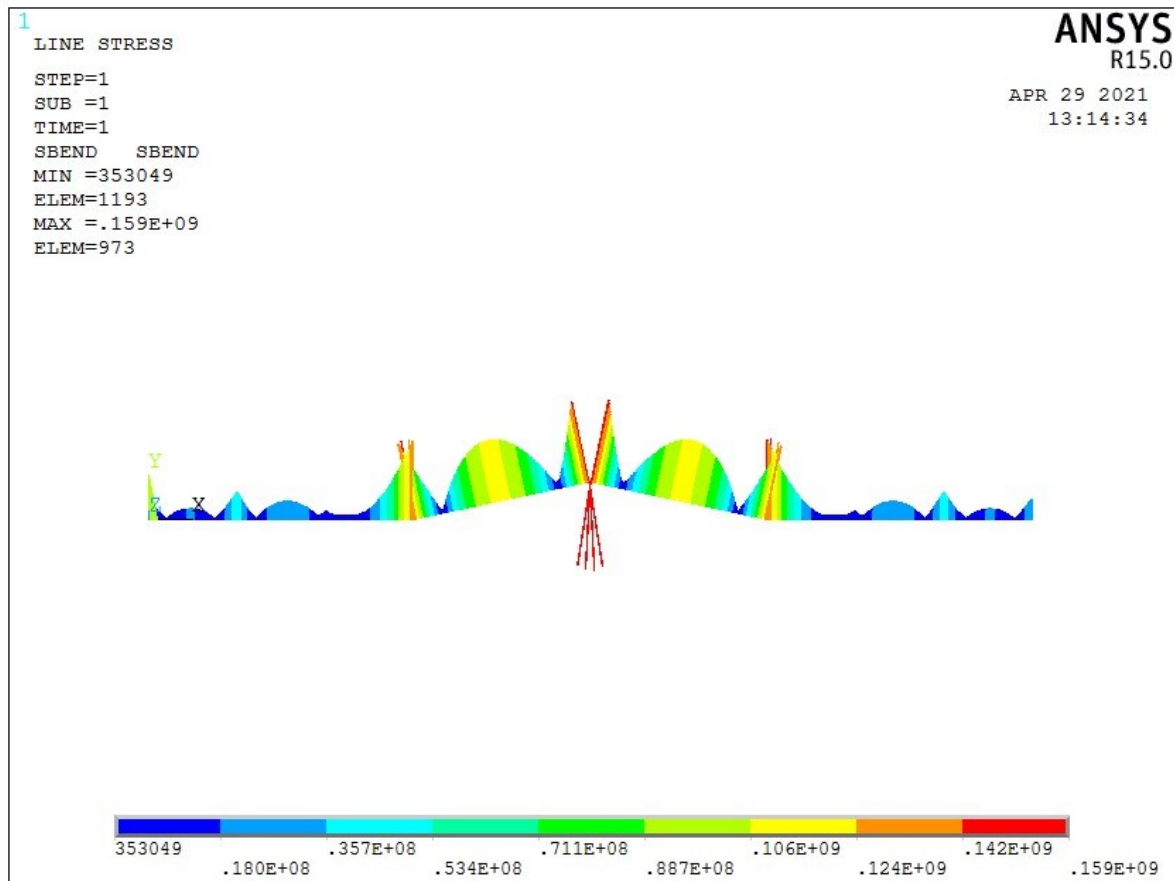

Figure 41: Distribution periods of equivalent stresses along the length of the compensating section

Conducted study on determination of strength, reliability and compensating capacity of above-ground compensating section by method of finite elements showed that accepted parameters of compensator with slightly bent section provide sufficient compensating capacity.

The completed studies have shown that the difficulty in implementing the cryogenic LAPG pipeline project is not only to maintain the required conditions of the single-phase pumping mode, but also to select the main strength parameters for the structure.

5 Results

The following results were obtained in this work. When analyzing the existing regulatory and technical scientific base and literature, it was revealed that the field of construction of main cryogenic pipelines for the transport of liquefied gases has not been sufficiently studied. However, there are many research papers and studies on cryogenic piping designs that meet the safety and efficiency requirements of trunk piping to varying degrees. There is extensive experience in the production and liquefaction of gas, as well as its transportation inside factory cryogenic pipelines, through tankers and cryogenic tank containers. To date, it is not possible to apply regulatory documents for the construction and operation of LNG and LAPG main cryogenic pipelines.

Chapter 3 investigated the theoretical basis of strength calculation, described the area of potential construction, and also determined the critical conditions of the parameters of the non-thermal LAPG pumping mode. Based on the results of the numerical experiments, the following optimal LAPG pipeline parameters were obtained for the given conditions. Pipe length not more than 120 km, diameter 114.3 mm, initial filling temperature -160°C , final pressure not less than 4 MPa.

In Part 4, strength was calculated and design solutions were optimized when laying cryogenic LAPG pipelines. For the cryogenic pipeline strength calculation, the factor $m = 0.5$ was adopted, which provides a double safety factor for the structure. The essence of the calculations was reduced to the determination of the equivalent stress value in the most dangerous section. It was concluded that for a 120 km long liquefied gas main cryogenic pipeline, the most dangerous and responsible section is the initial (0-20 km), since the initial pressure is 15 MPa and the product temperature is 160°C . The results of the calculations showed the possibility of ensuring strength at the given design loads at a wall thickness of 14 mm. At the same time, compensators can be used to compensate for temperature deformations (in sections 0-20), supports for accurate attachment at design elevations without bends (section 20-40), as well as limitation of the maximum closing temperature of the raft during installation (for section 0-20 km not more than -43°C , 20-40 km not more than -26°C , 40-60 km not more than -25°C , 60-80 km not more than -11°C , 80-100 km not more than 0°C , 100-120 km not more than 12°C).

Chapter 5 defined the compensator parameters for the cryogenic pipeline for application to the most responsible area. The main objective of this study was the application of high compensability in the above-ground area, that is, compensation of pipeline deformations from the effect of temperature difference and pressure, as well as ensuring high reliability of the structure by reducing maximum stresses in hazardous sections of the cryogenic pipeline. Conducted study on determination of strength, reliability and compensating capacity of above-ground compensating section by method of finite elements showed that accepted parameters of compensator with slightly bent section provide sufficient compensating capacity.

6 Conclusion

The feasibility of constructing a main cryogenic pipeline for the transport of liquefied associated petroleum gas is still open and region-specific. Every year, environmental standards are tightened, which in turn limits the release of APG from oil fields into the atmosphere. However, since APG can be used as a fuel for energy and heat supply to settlements remote from the center of industry, an economically profitable alternative to recycling appears - transport and use.

In Russia, in addition to Kuyumbinsky, other deposits are also scattered in very remote parts of the country. Pre-prepared and drained APG from the field can be transported by means of a cryogenic pipeline in liquefied form to small gas distribution stations, which will allow urbanizing uninhabited territories, providing settlements with fuel and contributing to the development of the economy and national economy in the regions. Today, APG can be prepared and liquefied right near the field, which makes the proposal to use the cryogenic pipeline rational and practically feasible.

Thus, in this work, studies were carried out aimed at the possibility of constructing a cryogenic pipeline in real conditions. It has been concluded that it is a great difficulty to implement such a pipeline not only to ensure the flow of liquefied gas in a single-phase stream, but also to ensure the strength and reliability of the structure being constructed. When constructing a main cryogenic pipeline, liquefied associated petroleum gas, it should be taken into account that its maximum possible length depends on specific climatic conditions that directly affect the strength calculations of the structure. Huge temperature difference between pumped LAPG and the environment, causes unacceptable stress strained state in the pipe, which can lead to accidents.

Today, the possibility of building a cryogenic pipeline using modern technologies is quite real, however, a severe lack of regulatory documents holds back the development of this branch of the oil and gas industry.

The improvement and application of new technologies in the field of hydrocarbon transport is moving very quickly. In the future, it is possible that cryogenic pipelines will be used not only as fishing pipelines, but also for the transport of the product over sufficiently distant distances.

References

- Akulykina, N., Andrianov, V., Zorkaltsev, V., Larionov, Logvin, G., Polozov, Fot, N., Sharigin, V. 1988. Refrigerated and liquefied natural gas main pipelines. Syktyvkar, p.157.
- Alexandrov, A., Benyaminovich, O., Odishariya, G., Gudkov, S., Hodanovich, I. 1968. Problems of transport and use of natural gas in liquefied and refrigerated conditions. Moscow, VNIIGAS, pp.42-49.
- Altova, V., Vasilyeva, A. 1977. Heat transfer at low temperatures. Moscow: Mir.
- Alyoshin, V., Seleznyov, V., Klinin, G., Kobaykov, V. 2015. Numerical analysis of underground pipelines strength. Moscow: Editorial RF.
- Antoshin, A., Chaburkin, V. 1976. Process strength of welded cold-resistant low-alloy pipe steels. VNIIST, p.176.
- Aynbinder, A. 2015. Calculation of main and field pipelines for strength and stability. Moscow: Nedra.
- Barmin, I., Chechulin Y., Kunis, I. 1996. Liquefied Natural Gas - Alternative Energy and Affordable Fuel. Refrigerating case, vol.3, pp.67-71.
- Bleyher, E. Vladimirov, A. 1973. Hydraulic and thermal conditions of the liquefied gas pipeline. Transportation and storage of gas, vol.5, pp.31-34.
- Bleyher, E., Vladimirov, A., Ivantsov, O., Polskiy, S. 1977. Liquefied natural gas pipeline transport. Moscow, VNIIEGasprom, p.63.
- Borodavkin, P., Berezin, V. 2016. Construction of main pipelines. Moscow: Nedra.
- Budzulyak, B., Dedeshko, A., Kanaykin, V. 2000. In-pipe injection of gas pipelines. Gas production, pp.46-47.
- Bykov, L., Besheryan, Z. 2019. Experimental studies of deformability and simulation of operation of above-ground pipelines on permafrost soils. Oil and Gas business, vol. 72, pp. 35-43.
- Chirikov, K., Ryabova, T., Voroshilov, V. 1976. Liquefied natural gas production. Methods and Equipment. Moscow: VNIIEGasprom.
- Chisholm, D. 1986. Fundamentals of oil and gas business. Moscow:Nedra.
- Dedeshko, V., Salyukov, A., Parfyonov, A. 1998. Maintenance and repair of main gas pipelines. Gas production, vol.21, pp.57-59.
- Dimentberg M. 1973. LNG pipeline may be answer to Arctic gas transport petroleum. Petrochemical International, vol. 8, pp.24-31.
- Dobrovolskiy, G. 1976. Determination of the state parameters of liquefied natural gas during its movement through the pipeline. AN USSR.
- Fastovskiy, V., Petrovskiy, Y. Rovenskiy, A. 1967. Cryogenic engineering. Moscow: Energiya.
- Fedosyev. V. 1999. Resistance of materials. Moscow: MVTU Bauman, second edition.
- Filin, N. 1973. Unknown processes in cryogenic systems. Overview information. Cryogenic and Oxygen Engineering. Moscow:TSINTIhimneftemash.
- Filin, N., Bulanov, A. 1985. Liquid cryogenic systems. Mechanical engineering, vol.4, pp.245-249.

- Foamed Plastic Masses. 1988. Cherkasy catalog.
- Gorbatskih, Y. 2000. Use of cryogenic fuels in prospective aircraft. Technical facilities of cryogenic infrastructure of natural gas liquefaction complexes, vol.5, pp.44-48.
- Haffner, A. 1970. Report of the committee on Natural Gas and Mass storage. Global gas consumption, vol.2, p.70.
- Ilyinskiy, A. 1976. Transport and storage of industrial liquefied gases.
- Ivantsov, O. 1968. Transport and storage of liquefied gas in France. Moscow: VNIOENG, p.12-14.
- Ivantsov, O., Dvoyris, A. 1980. Low temperature gas pipelines. Moscow: Nedra.
- Ivantsov, O., Livshits, L. 1976. Pipes for low temperature gas pipelines. Moscow, NIPIESUneftegasstroy, p.25.
- Ivantsov, O., Livshits, L., Rozhdestvenskiy, V. 1969. Construction of liquefied natural gas pipelines, Moscow, VNIIEGasprom, p.36.
- Kaganer, M. 1966. Thermal insulation in low temperature equipment. Mechanical engineering, vol.12, pp.42-56.
- Kirillov, N. 2002. Liquefied natural gas - a universal energy carrier of the 21st century: new production technologies. Industry, vol.3, iss.29, pp.113-118.
- Kirillov, N. 2003. Liquefied natural gas as a fuel for vehicles in Russia. Energy and Industry of Russia, vol.1, pp. 19-27.
- Korshak, A., Shammazov, A. 2002. Fundamentals of oil and gas business. Ufa:DesignPolygrafService, second edition.
- Korshak, A., Zabaznov, A., Novoselov, V., Matrosov, V., Klyuk, B. 1994. Pipeline transport of unstable gas condensate, Moscow, VNIOENG, p.204.
- Kunis, I., Morozov, V. 1998. Liquefied natural gas and urban ecology. Refrigerating case, vol.25, pp.45-51.
- Kutepov, A., Sterman, L., Styushin, P. 1986. Hydrodynamics and heat exchange during steam generation. Textbook for universities, Moscow:High School, third edition.
- Latypov, M., Polozov, A. Slepokurov, E 1993. Patent RF №3559816. Method of laying underground pipe string of pipe type in pipe.
- Livshits, L. 1968. Calculation of pipeline stability against brittle fractures. Notes of the Mining Institute, vol.5, pp.16-18.
- Livshits, L., Rozhdestvenskiy, V. 1968. Resistance of pipelines against brittle destruction, vol.3, pp.18-20.
- Makarov, E. 1970. Process strength of steel during austenite transformations (cold cracks). Mechanical engineering, vol.12, pp.54-62.
- Maks, M., Levi, R. 1976. Construction of LNG transshipment base at Kov-Poitna. Oil Engineer, vol.12, pp.12-23.
- Malkov, M. 1973. Manual of Physical and Technical Fundamentals of Cryogenics. Energy, vol. 5, pp.89-93.

- Malkov, M., Danilov, I., Zeldovich, L., Fradkov, A. 1973. Manual of Physical and Technical Fundamentals of Cryogenics. Moscow: Energiya.
- Matrosov, M., Zikeev, V., Martinov, P. 2016. Development of promising cryogenic steels for gas carriers and stationary storage tanks of liquefied natural gas for use in Arctic conditions. Shipbuilding for the Arctic, vol.4, pp.80-89.
- Nikolaev, M., Struchkova, G., Kapitonova, T., Efremov, P. 2015. Geo-environmental risks of pipelines in the north. Current trends in science and education, vol.5, pp.38-49.
- Nikolaev, A., Dokukin, V., Voronov, V. 2012. Analysis of existing methods for calculation of liquefied natural gas transfer modes through pipelines. Notes of the Mining Institute, vol.4, iss.199, pp.357-359.
- Nikolaeva, N. 1985. Determination of structural reliability parameters of non-contiguous sections of main pipelines operated under extreme conditions. Moscow:Nedra.
- Petrov, I., Spiridonov, V. 1973. Above ground piping. Moscow: Nedra.
- Polozov, A. 1986. Application of construction materials in the oil and gas industry. Prospects for development of gas pipeline main systems, vol.18, pp.100-105.
- Polozov, A. 1995. Test site for research, construction and operation of LNG pipelines. Piping Construction, pp.12-14.
- Polozov, A. 1997. Low temperature gas pipelines. Gas production, vol.11, pp.12-14.
- Polozov, A. 1999. Overhead gas pipeline. Gas production, vol.4, pp.53-54.
- Polozov, A. 2019. High strength of low-temperature heat insulated pipelines. Innovations of science, vol.5, iss.8, pp.26-40.
- Polozov, A. Patent RF №2551005. Vacuum insulated piping.
- Polozova, L. 1988. Refrigerated and liquefied natural gas main pipelines. Syktyvkar, p.157.
- Preobrazhenskiy, N. 1975. Liquefied petroleum gases. Moscow: Nedra.
- Rachevskiy, B. 2009. Liquefied hydrocarbon gas. Moscow, OilAndGas, 640 pages.
- Rakhmatullin, S. 2012. WFLH Pipeline Safety Issues. The Chemical Journal, vol.3, pp.24 - 28.
- Technical Guidance Material 26-04-1-67. Liquid Hydrogen Pipelines.
- Seleznyov, V., Alyoshin, V., Pryalov, S. 2016. Basics of Numerical Modeling of Main Pipelines. Moscow:MAKS Press, second edition.
- Semerikov, A. Patent RF №2715533. Device for liquefied gas discharge from low pressure tanks.
- Semerikov, A., Polozov, A. Patent RF №2731276. Cryogenic Fluid Drain Piping.
- Shaposhnikov, V., Polozov, A., Ilyushin, V. Manual on composition, design, manufacturing technology and installation of heat insulation of low-temperature pipelines (for pilot area). Moscow VNIIST, pp.353-379.
- Sharygin, A., Polozov, A., Sharygin, V. 1983. Thermal insulation strength under radial compression conditions. Oil and gas construction in the Far North. Moscow:VNIIST, pp.3-9.
- Set of Rules «SP» 36.13330-2012. Trunk pipelines.
- Set of Rules «SP» 86.13330.2014. Main (trunk) pipelines.

- Set of Rules «SP» 284.1325800.2016. Oil and gas field pipelines design and execution rules.
- Stolypin, V., Stolypin, E., Volchenko, A., Syrkin, A. 2009. Preparation of hydrocarbon mixture with high content of ethane fraction for transportation. Oil and gas business, vol.7, iss.1, pp.94-97.
- VNTN 51-1-88. Departmental regulations for the design of plants for the production and storage of liquefied natural gas, isothermal storage facilities and gas filling stations.
- Voronkov, S., Iserov, D. 1982. Thermal insulation of power plants. Moscow: High School, second edition.
- Vovk, V., Nikitin, B., Novikov, A., Grechko, A. 2011. Large-scale production of liquefied natural gas. Textbook for universities, Moscow: Nedra.
- Walker C. 1969. Liquefied natural gas pipelines for Arctic gas recovery. Gas Journal. vol. 338. № 5511. p. 366-368.
- Zatsepin, A. 1977. Development of the technology of construction of main pipelines of low-water and cooled natural gas. Moscow, VNIIST.
- Zhmakin, V. 2019. Development of methods and technical solutions for transportation of liquefied natural gas through low-pressure pipelines. Cryogenic technologies, vol.6, iss.20, pp.85-92.
- <http://cryoservice.ru/wp-content/uploads/2015/02/truboprovody-statiya.pdf>, accessed 04.04.2021
- https://edu.truboprovod.ru/kbase/doc/start/WebHelp_ru/troiniksnip.htm, accessed 06.04.2021.
- <https://gas-solutions.ru/news/virtualnyj-spg-truboprovod/>, accessed 18.03.2021.
- <https://gastopowerjournal.com/technologyinnovation/item/10522-edge-Ing-to-use-mobile-liquefaction-units-at-marcellus-shale>, accessed 18.03.2021.
- <https://nn.vo-da.ru/tool/cp-info>, accessed 10.04.2021.
- <https://uralrezerv.com/emkosti-dlya-hraneniya-i-transportirovki/tank-kontejnery>, accessed 02.04.2021
- <http://www.freepatent.ru/patents/2239746>, accesses 02.04.2021
- http://www.novatek.ru/ru/investors/disclosure/annual_reports/, accessed 03.03.2021.
- <https://www.popmech.ru/made-in-russia/249842-kak-sozdat-aerogel-novosibirskie-eksperimenty/>, accessed 06.04.2021.

List of Tables

Table 1: Classification of cryogenic pipelines by liquefied gas transfer, gasket types and extent	9
Table 2: Requirements for mechanical characteristics of pipe metal for LNG cryogenic pipelines	32
Table 3: Requirements for mechanical properties of steel according to ASTM A353, A553..	41
Table 4: Component composition of APG	47
Table 5: Pressure and temperature of pumped product in cryogenic pipeline sections	50
Table 6: Initial data for calculation	52
Table 7: Strength characteristics of steel	52
Table 8: Preliminary calculation of wall thickness of rectilinear section 0-20 km (mounting temperature 24.5°C).....	56
Table 9: Refined calculation of wall thickness of elastically bent section 0-20 km (mounting temperature 24.5 °C).....	56
Table 10: Preliminary calculation of wall thickness of straight section 0-20 km (mounting temperature -43°C)	57
Table 11: Refined calculation of wall thickness of elastically bent section 0-20 km (mounting temperature -43°C)	57
Table 12: Preliminary calculation of wall thickness of rectilinear section 0-20 km (mounting temperature -57°C)	58
Table 13: Refined calculation of wall thickness of elastically bent section 0-20 km (mounting temperature -57°C)	58
Table 14: Preliminary calculation of wall thickness of rectilinear section 20-40 km (mounting temperature 24.5°C).....	61
Table 15: Refined calculation of wall thickness of elastically bent section 20-40 km (mounting temperature 24.5°C).....	61
Table 16: Preliminary calculation of wall thickness of rectilinear section 20-40 km (mounting temperature -26°C)	62
Table 17: Refined calculation of wall thickness of elastically bent section 20-40 km (mounting temperature -26°C)	62
Table 18: Preliminary calculation of wall thickness of rectilinear section 20-40 km (mounting temperature -40°C)	63
Table 19: Refined calculation of wall thickness of elastically bent section 20-40 km (mounting temperature -40°C)	63

Table 20: Preliminary calculation of wall thickness of rectilinear section 40-60 km (mounting temperature 24.5°C).....	64
Table 21: Refined calculation of wall thickness of elastically bent section 40-60 km (mounting temperature 24.5 ° C).....	65
Table 22: Preliminary calculation of wall thickness of rectilinear section 40-60 km (mounting temperature -10.5°C)	65
Table 23: Refined calculation of wall thickness of elastically bent section 40-60 km (mounting temperature -10.5°C)	66
Table 24: Preliminary calculation of wall thickness of rectilinear section 40-60 km (mounting temperature -25°C)	66
Table 25: Refined calculation of wall thickness of elastically bent section 40-60 km (mounting temperature -25°C)	67
Table 26: Preliminary calculation of wall thickness of straight section 60-80 km (mounting temperature 24.5°C).....	68
Table 27: Refined calculation of wall thickness of elastically bent section 60-80 km (mounting temperature 24.5°C).....	68
Table 28: Preliminary calculation of wall thickness of straight section 60-80 km (mounting temperature 3°C).....	69
Table 29: Refined calculation of wall thickness of elastically bent section 60-80 km (installation temperature 3°C)	69
Table 30: Preliminary calculation of wall thickness of straight section 60-80 km (mounting temperature -11°C)	70
Table 31: Refined calculation of wall thickness of elastically bent section 60-80 km (mounting temperature -11°C)	70
Table 32: Preliminary calculation of wall thickness of rectilinear section 80-100 km (mounting temperature 24.5°C).....	71
Table 33: Refined calculation of wall thickness of elastically bent section 80-100 km (mounting temperature 24.5°C).....	72
Table 34: Preliminary calculation of wall thickness of rectilinear section 80-100 km (mounting temperature 14.5°C).....	72
Table 35: Refined calculation of wall thickness of elastically bent section 80-100 km (mounting temperature 14.5°C).....	73
Table 36: Preliminary calculation of wall thickness of rectilinear section 80-100 km (mounting temperature 0°C).....	73
Table 37: Refined calculation of wall thickness of elastically bent section 80-100 km (mounting temperature 0°C).....	74

Table 38: Preliminary calculation of wall thickness of straight section 100-120 km (mounting temperature 24.5°C).....75

Table 39: Refined calculation of wall thickness of elastically bent section 100-120 km (mounting temperature 24.5°C).....75

Table 40: Preliminary calculation of wall thickness of straight section 100-120 km (mounting temperature 12 ° C).....76

Table 41: Refined calculation of wall thickness of elastically bent section 100-120 km (mounting temperature 12°C).....76

Table 42: Initial data for model creation in Ansys.....79

Table 43: Geometrical characteristics of the compensating section81

List of Figures

Figure 1: LNG share in global gas trade	5
Figure 2: Condensate pipeline route at Purovsky GCPP	9
Figure 3: Tank-container for LNG transportation.....	11
Figure 4: Typical Virtual Pipeline Usage Scheme	12
Figure 5: LNG Virtual Pipeline.....	13
Figure 6: Methane Phase State Diagram	16
Figure 7: LNG flow modes in horizontal pipelines	17
Figure 8: Support for above ground laying of cryogenic LNG pipeline.....	19
Figure 9: Sliding structure of heat insulated pipe coating.....	20
Figure 10: Heat insulation structure for turning	21
Figure 11: LNG Cryogenic Piping Section Arrangement.....	22
Figure 12: Flexible cryogenic piping diagram.....	23
Figure 13: Cryogenic Fluid Drain Piping.....	24
Figure 14: Capsule design	25
Figure 15: Longitudinal section of cryogenic pipeline.....	26
Figure 16: Structural diagrams of inner pipe spacers relative to the casing.....	27
Figure 17: Expansion bellows	27
Figure 18: Connecting a Cryogenic Pipeline Section Using Bellows	28
Figure 19: Permanent connection of the pipeline section with vacuum insulation	28
Figure 20: LNG Transfer Schematic Diagram	29
Figure 21: Stress arising in the thin-walled model of the cylindrical shell	42
Figure 22: Estimated design diagram of elastically curved pipeline.....	44
Figure 23: Construction area overview.....	45
Figure 24: Associated petroleum gas phase state diagram	48
Figure 25: Distribution of phase state zones of fluid used in calculations	48
Figure 26: Change of pumped product temperature along pipeline length	49
Figure 27: Change of pumped product temperature along pipeline length	50
Figure 28: Initial pressure and temperature drop in each pipeline section.....	53
Figure 29: Elastically curved section	54

Figure 30: Stress distribution.....55

Figure 31: Distribution of longitudinal stresses on elastically bent section of pipeline59

Figure 32: Analytical dependencies of design solutions influence on stressed deformed state in 0-20 km section60

Figure 33: Analytical dependencies of design solutions influence on stressed strain state in 20-40 km section64

Figure 34: Analytical dependencies of design solutions influence on stressed deformed state in 40-60 km area67

Figure 35: Analytical dependencies of design solutions influence on stressed strain state in 60-80 km section.....71

Figure 36: Analytical dependencies of design solutions influence on stressed strain state in 80-100 km section.....74

Figure 37: Analytical dependencies of design solutions influence on stressed strain state 100-120 km77

Figure 38: Compensation systems during construction of above-ground pipeline section78

Figure 39: Compensation section design diagram81

Figure 40: Dependency distribution of stresses occurring in the compensating section.....82

Figure 41: Distribution periods of equivalent stresses along the length of the compensating section.....83

Abbreviations

APG	Associated Petroleum Gas
GCPP	Gas Condensate Processing Plant
HLP	Head Liquefied Plant
HPS	Head Pumping Station
IPS	Intermediate Pumping Station
LNG	Liquefied Natural Gas
LPG	Liquefied Petroleum Gas
LAPG	Liquefied Associated Petroleum Gas
LTS	Low Temperature Storage
PR	Pang Robinson
RP	Regasification Plant
SGPP	Sosnogorsk Gas Processing Plant
SSS	Stress Strain State

Nomenclature

C_n	Coefficient of resistance of melted soil
C_p	Coefficient of the normal resistance of the subsistence soil
C_{yo}	Unloading coefficient
D_o	External (outer) diameter of the pipe [m]
E	Young's modulus
h	Backfill height above pipe [m]
L	Length of the whole compensating section [m]
$L_{comp.actual}$	Length of the whole compensating section [m]
ΔP	Internal pressure drop [MPa]
$P_{initial}$	Initial pressure [MPa]
q	Ground resistance [kN]
$q_{np.soil}$	Maximum soil holding capacity above the pipe [kN]
q_{pb}	Pipeline buoyancy [kN]
q_{pipe}	Pipe weight load [kN]
R	Design resistance of melted soil [kN/m ²]
S_{oc}	Amount of subsidence [mm]
$T_{operation}$	Operation temperature of pipeline [°C]
$T_{product}$	Temperature of product [°C]
T_{soil}	Soil temperature [°C]
T_{wall}	Pipe wall temperature [°C]
ΔT	Pipe wall temperature drop [°C]
ν	Soil displacement factor
W	Axial moment of resistance [m ³]
α	Thermal expansion coefficient
δ	Pipe wall thickness [mm]
ε	Relative elongation of pipe [m]
λ_T	Thermal conductivity coefficient of frozen soil [W/m*°C]
μ	Poisson's coefficient
ρ_{min}	Minimal radius of elastic bend
σ_{axial}	Longitudinal axial stress [MPa]
σ_p	Pressure stress [MPa]

σ_r	Radial stress [MPa]
σ_t	Tensile strength [MPa]
σ_T	Temperature stress [MPa]
σ_y	Yield strength [MPa]
φ	Angle between straight and inclined section of compensator [°]