



Chair of Drilling and Completion Engineering

Master's Thesis



Downhole Data Transmission in Extended
Reach Drilling Utilizing Wired Drill Pipe
Technology

Aleksandr Verkhozin

May 2019

Affidavit

I declare in lieu of oath that I wrote this thesis and performed the associated research myself using only literature cited in this volume.

Eidesstattliche Erklärung

Ich erkläre an Eides statt, dass ich diese Arbeit selbständig verfasst, andere als die angegebenen Quellen und Hilfsmittel nicht benutzt und mich auch sonst keiner unerlaubten Hilfsmittel bedient habe.

Aleksandr Verkhozin



Name, 27 May 2019

Abstract

Currently used mud pulse telemetry technology has some drawbacks which limit the economic viability and feasibility of extended reach wells construction. Wired drill pipe technology as a means to transmit downhole data is being considered. The thesis focuses on economic feasibility assessment of wired drill pipes application for extended reach drilling through time and cost analysis.

The main project partner is OMV. The project has three advisors: Antony Martin (OMV), Prof. Gerhard Thonhauser (Montanuniversität Leoben), Prof. Aleksandr Oganov (Gubkin University).

History of wired drill pipe technologies is provided in chapter 2. The next chapter describes WDP enabled benefits in macro-areas of drilling, formation evaluation, production, and power supply. After that, two commercial wired drill pipe systems – IntelliServ and Powerline Drillstring – are highlighted.

Two extended reach wells are considered in the case study. Time savings resulted from implementation of wired drill pipe telemetry are calculated first. Then cost analysis of wired drill pipes utilization is conducted taking into account wired drill pipe related operational and capital expenditures and cost savings resulted from time savings. Finally, the author concludes whether wired drill pipe technology can make extended reach drilling more economically viable.

Zusammenfassung

Die derzeit verwendete Mud Puls Telemetrie-Technologie hat einige Nachteile, welche die Wirtschaftlichkeit und Machbarkeit der Errichtung von sogenannten extended reach wells einschränken. Wired drill pipe Technologie zur Übertragung von Bohrlochdaten wird erwogen. Die Arbeit konzentriert sich auf die Wirtschaftlichkeitsbewertung von Wired drill pipes für Bohrungen mit großer Reichweite durch Zeit- und Kostenanalyse.

Hauptprojektpartner ist die OMV. Das Projekt hat drei Berater: Antony Martin (OMV), Prof. Gerhard Thonhauser (Montanuniversität Leoben), Prof. Aleksandr Oganov (Gubkin University).

Die Geschichte der Wired drill pipe Technologie ist in Kapitel 2 dargestellt. Das nächste Kapitel beschreibt WDP-fähige Vorteile in den Makrobereichen Bohren, Formationsbewertung, Produktion und Energieversorgung. Danach werden zwei gewerbsmäßige Wired Drill Pipe Anlage - IntelliServ und Powerline Drillstring - vorgestellt.

In der Fallstudie werden zwei extended reach wells erwogen. Die Zeitersparnis, die sich aus der Implementierung der kabelgebundenen Bohrrrohrtelemetrie ergibt, wird zunächst berechnet. Anschließend wird eine Kostenanalyse der Nutzung von Wired drill pipe Betriebs- und Investitionskosten sowie der Kosteneinsparungen durch Zeiteinsparungen betrachtet. Letztendlich kommt der Autor zu dem Schluss, ob die Verwendung der Wired Drill Pipe Technologie wirtschaftliche Vorteile hat.

Acknowledgements

I want to thank everyone who helped me while I was writing the Master thesis:

- Industry Advisor Antony Martin
- Montanuniversität Leoben Advisor Prof. Gerhard Thonhauser
- Gubkin University Advisor – Prof. Aleksandr Oganov
- OMV for financial sponsorship and project partnership
- OMV Mentor Andreas Scheed for trusting relationships
- Project third party TDE Group and Medardus Ramsauer personally
- Gubkin University
- Mikhail Gelfgat and Vladimir Balitskiy for promoting the Joint International Master Program
- Chair of Drilling and Completion Engineering Advisor Anton Lettner
- 3rd party Advisor Yuriy Bedyuk
- 3rd party critiques Andrey Zhenevskiy and Mikhail Slepov
- Logistics Engineer of LLC „Gazprom Bureniye“ Dmitriy Ostapenko
- Aleksandr Fain
- Groupmates
- Family
- Girlfriend

Contents

- Chapter 1 Introduction 1
 - 1.1 Problem description..... 1
 - 1.2 Wired drill pipe telemetry as a solution2
 - 1.3 Project objectives3

- Chapter 2 History of wired drill pipe technologies..... 4
 - 2.1 Early inventions.....4
 - 2.2 TRAFOR 5
 - 2.3 ELECTRIC DRILLSTRING 5
 - 2.4 IntelliServ 5
 - 2.5 DualLink..... 6
 - 2.6 Powerline Drillstring 6
 - 2.7 Micro-repeater WDP telemetry system.....7
 - 2.7.1 System architecture7
 - 2.7.2 Field trials 8

- Chapter 3 Wired drill pipe enabled applications..... 9
 - 3.1 Drilling..... 9
 - 3.1.1 Steering advisory systems9
 - 3.1.2 Detection and mitigation of drilling dysfunctions..... 10
 - 3.1.3 Hole cleaning..... 11
 - 3.1.4 Data transmission 11
 - 3.1.5 Pumps off data availability 12
 - 3.1.5.1 Tripping..... 12
 - 3.1.5.2 ECD with low flow - pack-off recovery 12
 - 3.1.5.3 Downhole pressure signature on connections 12
 - 3.1.5.4 Downhole dynamics data with low flow..... 12
 - 3.1.5.5 Kick identification and circulating out..... 12
 - 3.1.5.6 Drilling with losses..... 12
 - 3.1.6 Managed pressure drilling 13
 - 3.1.7 ROP optimization 13
 - 3.1.7.1 No controlling ROP to acquire M/LWD real-time data density 13
 - 3.1.7.2 Monitoring of drilling parameters for higher ROP 13
 - 3.2 Formation evaluation 14
 - 3.3 Production..... 15
 - 3.4 Power supply 15

Chapter 4 Commercial wired drill pipe systems.....	16
4.1 IntelliServ	17
4.1.1 IntelliServ Version 1	17
4.1.1.1 Technological description	17
4.1.1.2 Major problems experienced	21
4.1.1.3 Reliability metrics.....	22
4.1.1.4 Summary of the campaigns	24
4.1.2 IntelliServ Version 2	26
4.1.2.1 Lessons learned from Version 1	26
4.1.2.2 Wired drill pipe improvements	27
4.1.2.3 Improvements to downhole network electronics.....	31
4.1.2.4 Surface electronics improvements	31
4.1.2.5 Anticipated benefits from IntelliServ Version 2	31
4.1.3 Feedback from service companies	32
4.1.3.1 Early feedback (2003 – 2006).....	32
4.1.3.2 Wamsutter field campaign.....	32
4.1.3.3 Trinidad campaign.....	32
4.1.3.4 MPD with WDP in Mexico	32
4.1.3.5 Babbage field campaign	33
4.1.3.6 IntelliServ Version 2.....	33
4.1.3.7 Summary of feedback from service companies	33
4.1.4 Feedback from operators.....	34
4.1.4.1 Troll field campaign.....	34
4.1.4.2 Visund field campaign	34
4.1.4.3 Van Gogh field campaign	34
4.1.4.4 Elk Hills field campaign.....	35
4.1.4.5 Babbage field campaign	35
4.1.4.6 Martin Linge field campaign	35
4.1.4.7 Summary of IntelliServ in BP	36
4.1.4.8 Summary of feedback from operators.....	37
4.1.5 Why IntelliServ has not made a market breakthrough.....	38
4.2 Powerline Drillstring	40
4.2.1 System structure	40
4.2.2 PDS power supply.....	40
4.2.3 PDS tests	41
Chapter 5 Time savings resulted from implementation of wired drill pipe telemetry for extended reach drilling.....	42
5.1 Data transmission time	43
5.1.1 Directional surveys.....	43
5.1.2 RSS downlinks	44
5.1.3 Motor toolface orientation.....	44
5.1.4 Formation pressure tests	45
5.2 Increased ROP	45
5.3 Bit/BHA run reduction.....	47

5.4 Hole cleaning time	47
5.5 Time savings summary	48
Chapter 6 Cost analysis of wired drill pipe telemetry utilization for extended reach drilling.....	49
6.1 Cost savings	49
6.1.1 Cost savings resulted from time savings.....	49
6.1.2 Downhole tools cost reduction	49
6.2 Additional expenditures	50
6.2.1 CAPEX.....	50
6.2.2 OPEX.....	57
6.3 Cost summary.....	58
Chapter 7 Conclusion.....	59

Chapter 1 Introduction

1.1 Problem description

As drilling conditions become more challenging, the need for real-time information from wells being drilled increases. There are different telemetry methods developed, but the vast majority of wells were drilled relying on mud pulse telemetry (MPT).

Mud pulse telemetry presents several limitations to data flow during drilling process:

- MPT does not work in high loss situations, as it requires a full mud column in the drill pipe.
- Activation balls and wiper darts cannot pass through the restricted borehole.
- The passage of lost circulation materials, cement or proppant particles is limited.
- The inability to transmit data when flowrate is lower than a threshold activation value. (Hawthorn and Aguilar, 2017)
- MPT may not be possible with foam.
- The requirement that all sensors should be close to the mud pulser prevents distributed measurements along the drill string. (Reeves et al., 2005)
- Mud pulse telemetry needs much time to transmit data: about 8 h/(km drilled). (Schils et al., 2016)
- A pulsing signal experiences disturbances which make its decoding challenging. Noise sources are bit and drill string vibrations, BHA, signal reflection and mud pumps. If a problem with decoding occurs, it takes time to recognize its causes and change some drilling parameters or surface equipment in order to reduce the noise.
- Mud pulse telemetry data rate is limited: up to 20 bit/s (Klotz et al., 2008). The data rate drops with increasing length of the wellbore and is typically 1.5 – 3.0 bit/s at a depth of 11 – 12 km.

As for alternatives to MPT, acoustic telemetry through the wall of the drill pipe provides 30 bit/s data rate (Reeves et al., 2011), electromagnetic through-the-Earth telemetry – up to 100 bit/s, but it is generally reliable to depths shallower than 3 km (Schnitger and Macpherson, 2009).

These relatively low data rates force multiple sensors to compete for bandwidth. Sometimes the only way to get the complete data set is rate of penetration reduction. Otherwise, bad quality of real-time logs leads to wrong decisions.

These shortcomings increase well construction costs and even make some projects unfeasible.

1.2 Wired drill pipe telemetry as a solution

Several oilfield service companies are currently developing wired drill pipe (WDP) systems. They promise data transmission rates orders of magnitude greater than anything possible with other kinds of telemetry – up to 1 Mbps (Macpherson et al., 2019).

When using low-latency data from logging while drilling (LWD), measurements while drilling (MWD), and along-string measurement (ASM) tools in real time, decisions are made on the fly rather than during a post-well investigation. The bandwidth allows for these data streams to flow to surface without any compromise in rate of penetration (ROP).

To date, MWD and LWD tools are powered from battery packs or downhole turbine alternators. Their application makes both manufacturing and maintenance of these devices more expensive. And WDP systems offer a solution. Powerline Drillstring (PDS) supplies downhole tools with power without any turbines and batteries, which improves their economics.

As for extended reach drilling (ERD), WDP systems addresses its main challenges. Based on ASM data, hole cleaning may be optimized. Additionally, torque and drag issues such as pipe buckling and poor weight transfer can be resolved via drilling dynamics data analysis (Giltner et al., 2019). Pressure ASMs enable equivalent circulating density (ECD) monitoring and even ECD management, if we consider managed pressure drilling (MPD) applications. Finally, modern steering advisory systems are able to drill and land wells accurately and smoothly within tight targets. Such systems minimize tortuosity in the wellbore that can result in high drag forces in long lateral runs (Zalluhoglu, Gharib et al., 2019). If mud pulse signal degradation that occurs at extreme depth limits drilling ahead, using wired drill pipe allows the ERD envelope to be expanded while maintaining high data rates and control over rotary steerable system (RSS) settings.

Wired drill pipe technology is not only promising for high-profile wells, including ERD, but also ties in with digitalization of the industry, when information about downhole parameters itself becomes a valuable asset. WDP as a high data bandwidth bidirectional communication method between surface and downhole removes a barrier to automation of the oil field.

But reliability and failure mechanisms of wired drill pipes are not completely understood. Finally, wired drill pipes manufacturing and servicing costs are higher in comparison with standard drill pipes. Implementation of WDP system is still waiting for detailed economic justification, comparing earnings resulted from possible technical improvements with the corresponding increase in expenditures.

1.3 Project objectives

The thesis purpose is to assess economic feasibility of wired drill pipe technology utilizing for ERD.

Objectives to reach the purpose:

- To consider the concept and specifications of WDP telemetry with a comparison to mud pulse telemetry having regard to surface power supply.
- To consider WDP enabled benefits in the areas of:
 - drilling;
 - formation evaluation;
 - production;
 - power supply.
- To describe commercial WDP systems in terms of:
 - operating principle;
 - performance characteristics;
 - failure mechanisms and reliability metrics;
 - handling procedures and network maintenance;
 - field experience.
- To estimate how wired drill pipes application reduces well construction time in terms of:
 - drilling;
 - tripping;
 - data transmitting;
 - telemetry network maintenance;
 - avoiding problems.
- To conduct cost analysis of wired drill pipes utilization for ERD taking into account:
 - upfront capital expenditures (CAPEX) to install WDP system;
 - operational expenditures (OPEX) related to the rental of equipment and additional personnel on the rig;
 - time savings;
 - reduction of OPEX due to battery and turbine removal.
- To conclude if wired drill pipe technology makes extended reach wells more economically viable.

Chapter 2 History of wired drill pipe technologies

2.1 Early inventions

The idea of transmitting electric signals along the drill string was recognized over 80 years ago (Karcher, 1932). As early as 1939, technology had been proposed to link serial drill string components to provide a network for the transmission of power and data from the bottom of the hole to the drilling platform on the surface.

In 1942, Hare suggested the use of inductive coupling in order to link the drill string. The chief drawback of his system was the high power consumption due to magnetic field losses in the surrounding steel of the drill pipe.

Cloud also filed a patent application in 1942 for a serial inductive coupling system. He suggested the use of a v-shaped trough of a magnetic alloy for focusing the inductive signal. But eddy-current losses were too high.

In 1963, Lord reduced the power required in Hare's system. But the low life of the batteries, and the difficulties associated with their installation resulted in a lack of commercial support (Jellison et al., 2003).

Drilling with electrical power has been used in the USSR. The electrical power cable was suspended in the center of the drill pipe, and the electrical connection made by a stab and seal arrangement was screwed together. A conventional 3-phase power cable was used. The large outer-diameter (OD) electrical connector occupied the inner diameter (ID) of a tool joint, resulting in a smaller flow area at every coupling.

The reliability of the electrical system was very good when new, however, after several trips into the well the failure rate went up to 1 connector failure per km drilled. Usually, the elastomer was deteriorated due to its exposure to drilling fluids and downhole vibrations, resulting in fluid ingress and short circuit. (Lurie et al., 2003)

Much development effort has been expended by Shell and Exxon Production Research on telemetry through hardwired conductors. (Gravley, 1983)

In 1986, Meador described another configuration for coupling of the drill pipes. Meador envisioned a current-coupled system that used discrete coils at each joint, insulated from the steel and joined to coils at the other end of the pipe by a conductor wire. Thus, Meador reduced electrical leakage to the surrounding steel. However, his system required high power and produced a low frequency signal that had limited bandwidth and high noise-to-signal ratio.

In January 1987, Howard described a system that utilized a Hall Effect sensor as a means to bridge the drill pipe joint. But the signal was unidirectional, and it required complex electronic circuitry and battery power.

In July 1987, Veneruso filed an application that employed the use of a ferrite core. This system relied on conductor wire power supply from a source at the surface. (Jellison et al., 2003)

2.2 TRAFOR

From early 1980s, for more than ten years, French Institute of Petroleum has studied, conducted experiments and tested in the field wired drill pipe telemetry system TRAFOR. The data rate of the system is 30 kbit/s (Fay et al., 1992). The downhole-to-surface electric link is composed of two main elements:

- wired drill pipes equipped at the upper section of the drill string, and,
- a conductor cable located between the lowest wired pipe and the downhole sensor package to complete the depth drilled.

Each wired pipe is fitted with an internally mounted conductor and two electrical connectors at the pin and box joints. The contact conductive rings are automatically mated during joint make-up. The system was designed to operate down to a depth of 3 km. (Fay et al., 1992)

A personal computer, which performs the processing and storage functions, receives two data flows: from downhole and surface sensor subs.

Rigging the drill pipe with electrical conductors and the necessary connectors proved to be difficult and expensive. Successful field tests have been performed, but commercial systems are not available.

2.3 ELECTRIC DRILLSTRING

Lurie et al. (2003) presented a paper about their efforts to develop an electric drillstring. Phases of feasibility and benefit assessment have been completed. Two connection designs were short-listed as potential solutions. Authors concluded that WDP system implementation would be beneficial. But no other publications were presented since that time. A commercial ELECTRIC DRILLSTRING does not exist.

2.4 IntelliServ

Development of the high-speed telemetry started in 2001 (Pixton, 2005). The data rate is 57 kbit/s (Reeves et al., 2006). The communication link includes a data cable traveling the length of each drill pipe (Jellison et al., 2003). The cable terminates at inductive coils that are installed in the pin nose and corresponding box shoulder and transmit data across each tool joint interface (Reeves et al., 2005).

The first generation of Intelliserv WDP has been in commercial use since 2006. Version 2 of WDP with improved reliability was presented in 2014 (Craig and Adsit, 2014).

Overall, more than 250 wells have been drilled using the Intelliserv WDP telemetry (Foster and Macmillan, 2018).

This technology will be discussed in detail in chapter 4 “Commercial wired drill pipe telemetry systems”.

2.5 DualLink

Since 2004, Reelwell AS, a company from Norway, has been developing DualLink¹. It is a wired drill pipe system delivering high speed telemetry. By supplying downhole tools with electrical power, DualLink will reduce batteries, turbines, and mechanical pulsers. No repeaters will be required. The technology enables ASMs.

DualLink is still under development. A commercial system has not been released yet.

2.6 Powerline Drillstring

TDE Group has developed WDP system Powerline Drillstring² which provides both electrical downhole power from surface and high-speed real-time bidirectional data communication. The data rate is 500 kbps. The continuous electrical power is 300 W. It means that downhole batteries and turbines can be eliminated. The system assumes standard pipe handling and conductive mechanical tool joints. PDS was successfully field-tested with IRIS in Norway.

This technology will be discussed in detail in chapter 4 “Commercial wired drill pipe telemetry systems”.

¹ Information on DualLink is taken from website <https://www.reelwell.com/duallink>

² Information on PDS presented here come courtesy of TDE Group via personal communication with Drilling / Mechanical Engineer Medardus Ramsauer in spring of 2019.

2.7 Micro-repeater WDP telemetry system

Macpherson et al. (2019) presented smart wired pipe. The development and successful field trial of this micro-repeater WDP telemetry system is described below.

2.7.1 System architecture

The wired pipe system consists of a downhole interface sub, the wired pipe string, and a wireless surface interface system.

Each joint of wired pipe consists of couplers in the pin and box of the pipe, two wires linking the couplers, and a micro-repeater loaded in the box of each joint.

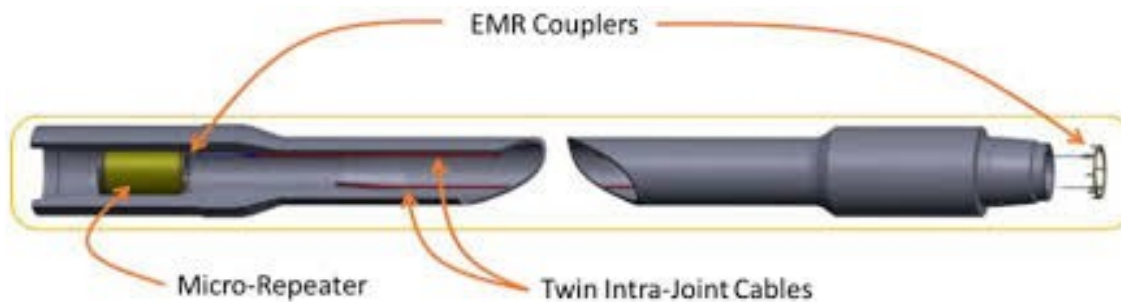

Figure 1: Components in a joint of drill pipe of a micro-repeater based wired pipe system (Macpherson et al., 2019)

The current system delivers 1 Mbps backbone data rate with a maximum payload of 720 kbps, and with a latency of 15 μ s/km.

The wired pipe telemetry system uses electromagnetic resonance (EMR) coupling. The antennas can function over a gap of about 8 mm, and that gap can be fluid filled. Each coupler contains two semi-circular antennas that overlap with the antennas in the adjacent joint of pipe, allowing for the signal crossover.

The developed system uses battery-powered micro-repeaters placed within the box of each tubular. These micro-repeaters boost the signal traveling up and down the drill string. The micro-repeaters are field replaceable and can be loaded on location.

The micro-repeaters have fail-safe circuitry. If a micro-repeater fails, the signal shorts through to the next joint of pipe. Up to two micro-repeaters in series can fail before the signal is lost due to attenuation.

In addition, any micro-repeater provides an access point (along string subscriber) to the data stream. This makes for easy addition of along-string sensors. The micro-repeaters sense temperature, which will provide a real-time fluid temperature profile.

There are two cables in each tool joint for redundancy. The system has a multi-path signaling capability that delivers reliability. Signal travelling along each wire may crossover to the adjacent wire at each coupler.

2.7.2 Field trials

The first full-scale drilling test of the prototype system occurred in 2016 in Oklahoma, while a control test of the downhole technology occurred in 2017.

Except for the non-conductive pipe-dope, handling was no different from handling standard unwired drill pipe. The drilling trial demonstrated fitting the system to pipe with conventional API connections. As the surface system is wireless, no modification to the drilling rig was required.

The test closed without any damaged equipment and errors introduced by the wired pipe data tunnel. The testing verified the robustness of the system by single and double failures by switching off repeaters.

The field test demonstrated the suitability of the micro-repeater concept over a length of about 1 km.

The system is now under development for production. The vision is to use the wired pipe as an open platform for both downhole and along-string measurements.

Chapter 3 Wired drill pipe enabled applications

This chapter considers WDP enabled benefits in macro-areas of:

- drilling;
- formation evaluation;
- production;
- power supply.

3.1 Drilling

Firstly, WDP is a high-speed telemetry. Instantaneous well data transmission and downlinks save time themselves. Secondly, these data gathered via WDP serve as inputs for different tasks, such as steering, trouble-shooting, MPD, hole cleaning and ROP optimization.

3.1.1 Steering advisory systems

The system for mud motors which combines the physics of the BHA, rig surface sensor data, field experience, and wellbore positioning requirements is described by Zalluhoglu, Gharib et al. (2019). The model automatically calibrates itself in real-time using MWD and LWD information to capture and evaluate the directional response of the mud motor.

The system for RSS is described by Zalluhoglu, Demirer et al. (2019). The inputs to the system are the real-time data feed from the RSS, MWD, and LWD sensor packages. Based on the inputs, the system generates real-time steering-related commands (e.g., steering magnitude, toolface, weight-on-bit (WOB), flow rate). It can operate either in the advisory mode to provide steering-related recommendations to directional drillers or in automatic control mode, where downlink commands are generated and communicated to the rotary steerable system automatically.

Based on the real-time bending moment data, autopilot steering systems can proactively adjust drilling parameters to mitigate the high local doglegs, thus reducing wellbore tortuosity (Wolter et al., 2007). The systems mentioned above were tested on multiple commercial jobs across North America. By exactly following the advisory system-generated steering decisions, multiple curve sections were smoothly drilled and accurately landed within tight windows.

The systems have been helping directional drillers make more informed and consistent steering decisions by evaluating the tool performance and characterizing formation disturbances in real time.

These technologies allow directional drillers to focus more on the overall directional process instead of making routine steering decisions. The systems also enable a directional driller to remotely manage multiple wells simultaneously.

3.1.2 Detection and mitigation of drilling dysfunctions

With the better real-time picture of the downhole drilling environment, engineers can reveal drilling dysfunctions at an earlier stage than before. Via the wired drill string, all L/MWD system diagnostic data is available at surface in real-time. This allows technicians to troubleshoot problems faster and with greater certainty. In some cases, this will allow operations to continue or, if pull-out-of-hole (POOH) is required, it provides the opportunity to be fully prepared to change out the problematic component as soon as the BHA is at surface without the need for further time-consuming trouble shooting and component lifting at surface.

As for wellbore stability, increases in telemetry rates have enabled its real-time visualization. High-definition low-latency electrical imaging allows identification of wellbore failures and natural fracture networks which can be used for instantaneous decision-making (Wolfe et al., 2009).

In addition, LWD imaging tools are able to deliver time-lapsed visualization of time-dependent borehole instability feature development. Time-lapse imaging improves completion decisions: casing sections that have been planned for may be eliminated in case the wellbore conditions do not deteriorate over time. On the other hand, time-lapse image logs may discover the need for running a contingency casing (Wolfe et al., 2009).

If downhole vibrations from along the entire string can be monitored and assessed in real-time, critical regimes can be avoided to reduce the risk of fatigue failures in tubulars. Fishing jobs and drill string damage could thus be avoided. High frequency near-bit vibration data can be used to optimize bit life and drilling mechanics parameters and identify bit wear (Reeves et al., 2005). It is possible to determine when a bit run is necessary. This can increase the time between bit runs and eliminate unnecessary bit runs. Giltner et al. (2019) show how WDP data helped to mitigate motor micro-stalls, pipe buckling and improve weight transfer to the bit.

WDP proved to be useful for pipe washout identifying and locating. The pressure sensors can detect a pressure loss and confirm that it is caused by a pipe wash-out, while also returning the likely location of the pressure-gradient reduction (Veeningen, 2011).

An indirect benefit of reduced surveying time enabled with WDP is having to maintain the drill string stationary for a shorter period of time. This will help mitigate the potential for stuck drill string and hole cleaning problems.

Finally, WDP technology has an advantage over MPT in the area of circulation-loss control. Conventional MPT pulsers are vulnerable to blockage when lost circulation materials (LCM) are pumped (Hernandez et al., 2008). But WDP system are not affected by LCM.

3.1.3 Hole cleaning

ECD data measured along the drill string are the base for reduction of hole cleaning circulation time. Furthermore, it is possible to optimize conditioning trips. Based on a previous experience of the relationship between hole conditioning at connections and hole cleaning efficiency, the system determines all the relevant parameters for the connection: pump rate, string rotations per minute (RPM), and the necessity for several passes (Hovda et al., 2008).

3.1.4 Data transmission

Firstly, WDP systems provide high-speed data channel, which makes survey time negligible. Data can be transmitted to full sensor accuracy in real-time for near-instantaneous verification. This will allow immediate identification of poor-quality data.

Secondly, coupling of existing downhole tools to a surface control computer via the network eliminates the flat time associated with current 'downlink' methods. RSS and seismic while drilling (SWD) tools are possible instantaneous downlinking applications. Activating of integrated reamers (main and near bit) is also possible with WDP. It means no need for an additional trip to open up the rat hole.

Thirdly, with the capability to deploy a drill string telemetry network in parallel with a standard mud pulse telemetry tool, operators have access to data transmission redundancy, reducing the frequency of lost time associated with data flow interruption (Reeves et al., 2006).

Fourthly, if all data deliverables are presented via the wired drill string and fully quality-controlled before the tool returns to surface, there is no immediate need to download memory data at surface. This can save time.

Finally, WDP telemetry simplifies shallow hole testing. It is a common practice to shallow test BHA's when running in hole as a check of functionality. If the mud is cold and unsheared, it might be difficult to fully decode MPT signals. This can cause uncertainty in the shallow hole test. Using the wired drill string, the MPT functionality can be checked by simply observing pulses without the need for decoding while full system functionality is attained in parallel via the data link through the wired drill string.

Additionally, with an RSS in hole, it is common practice to also check that the downlink communication functions correctly at this time. Downlinking functionality can also be checked directly via the wired drill string.

3.1.5 Pumps off data availability

3.1.5.1 Tripping

PDS sensors at the drill string can work during tripping as the power and data connection with the drill string is established. It is possible to monitor surge and swab effects. The whole well may be logged again to double check or to get better quality measurements as the drill string is not rotating.

3.1.5.2 ECD with low flow - pack-off recovery

After packing off and losing circulation, wired pipe can provide pressure measurements while trying to regain circulation from the BHA and places along the drill string. As pumps are brought back up (too slowly to activate mud pulse telemetry) it is possible to measure if the hole is still packed-off and, if so, where, and manage the flow rate to prevent further losses and aggravation of the loss zone (Veeningen, 2011).

3.1.5.3 Downhole pressure signature on connections

The shape and character of the downhole annular pressure on connections is a diagnostic tool for borehole breathing/ballooning (Ward and Clarke, 1998; Bratton et al., 2001, Edwards et al., 2002) and for differentiating between the later and taking a kick. Such pressure measurements are usually not available until the tool memory data is downloaded at the end of the run. With wired pipe, as long as the network is connected the data is visible.

3.1.5.4 Downhole dynamics data with low flow

Low flow rates are sometimes used to kick-off a cement plug to sidetrack a well. Downhole dynamics data can be useful in these situations. Running other tools in hole, e.g. during completions or interventions, if performed on drill pipe with the dynamics tool in the hole, can provide useful information such as downhole weight on bit, which can help determine if the tools are being properly placed and/or hung up.

3.1.5.5 Kick identification and circulating out

With WDP systems, ASM pressure data are available even without circulation. Thus, kicks may be revealed. Usually, the kill rate is insufficient for MPT. With the WDP network, high-resolution along-string pressure readings are known at all times during the well kill, which helps monitor as the influx travels up the hole (Veeningen, 2011).

3.1.5.6 Drilling with losses

If there are no returns while pumping, it is not safe to drill blind as the hydrostatic pressure in the annulus is not known and could drop below that of the formation pressure at some point, inducing a kick (Edwards et al., 2013). With WDP, visibility of the downhole annular pressure would provide a measure of the annular mud column height. It is possible to maintain hydrostatic mud pressure above formation pressure. In other words, drilling with losses using WDP can be performed more safely.

3.1.6 Managed pressure drilling

The main potential of high-speed drill string telemetry used in combination with MPD is related to automated well control, including detection and handling of well control incidents, as demonstrated by Fredericks et al. (2008). ASM pressure data may be used to monitor ECDs to stay within mud window while MPD.

Instantaneous transmission of pressure/temperature data will provide kick detection (Reeves et al., 2005). Kick volume and kick zone depth can be estimated. The total influx rate is accurately estimated within 100 s after the kick initiates (Gravdal et al., 2010).

Another potential of high-bandwidth downhole measurement is improved model calibration and characterization of downhole conditions. Information available from ASMs is useful in model parameter estimation, including friction factor and annular fluid density.

If it is required to maintain constant BHP during connection making, the system can adjust both the surface back-pressure and mud pump flow rate. The data transmission between the well and surface is only lost the limited time it takes to put in the new stand (Pixton et al., 2014).

WDP has enabled underbalanced managed pressure drilling otherwise undrillable wells, has provided real-time information in fluid conditions that don't support other methods of communication (Pixton et al., 2014).

3.1.7 ROP optimization

3.1.7.1 No controlling ROP to acquire M/LWD real-time data density

If MPT is used and the data rate becomes not enough to support critical decisions in real-time, the only way to get the complete data set is to reduce rate of penetration. Then drilling is technologically feasible, but the underperformance increases well construction time and, eventually, costs.

WDP telemetry removes the bottleneck and provides several orders of magnitude higher data bandwidth, which means that fast drilling and real-time data transmission are achievable simultaneously.

3.1.7.2 Monitoring of drilling parameters for higher ROP

With effective real-time utilization of downhole data, the stand is drilled down with optimized process parameters. By controlling the vibration levels within predetermined margins, applying optimal weight on bit and drill string RPM, a maximum part of the applied energy will be used to cut new formation (Ali et al., 2008).

The system computes optimal WOB from automatic drill-off test performed for every major lithology change or with preprogrammed frequency. Every measurement is compared with previous measurements and any deviation from the optimal trend is interpreted and process inputs adjusted. The system will choose the optimal combination of drilling parameters.

3.2 Formation evaluation

WDP provides clean digital signal, which means:

- no detection problems;
- no data loss;
- no signal conversion;
- rapid log interpretation.

If all required logs were delivered in real-time without gaps, there is no need to perform wireline logging.

If MPT is used, data processing is done downhole as just most important data can be sent (10–20 bit/s). But with WDP data processing can be done uphole with cheap computers. Moreover, if WDP system is deployed without back-up MPT, mud pulser is removed from MWD tools (Reeves et al., 2005).

As for WDP data analysis, monitoring of existing formation pressure while drilling tools allows accurate determination of true formation pressure and provides visibility of actual buildup/draw down curves for permeability calculation while drilling. Pore pressure models can be updated from LWD pressure, acoustic and seismic measurements and used to predict pressure ahead of the bit for refining drilling parameters before a problem occurs.

Another valuable feature of WDP systems is pumps-off data availability. Firstly, high frequency downhole pressure measurement is available during a leak-off test. Real-time high frequency (2 second data) downhole data proved useful when there was a critical need to carefully conduct the leak-off test just to leak-off point but not beyond.

Secondly, WDP telemetry is applicable for identification of loss zone. When losses occur, flow rates are typically reduced – MPT does not work then. However, it may often still be desirable to be able to locate the loss zone. With WDP, independent on the mud flow, the loss zone may be detected from resistivity profile, temperature profile, or image logs (Edwards et al., 2013).

Moreover, WDP gives positive synergy with seismic while drilling. The network's ability to synchronize tool clocks with greater than millisecond accuracy eliminates the need for high-cost, low-drift downhole clocks in support of seismic while drilling applications (Reeves et al., 2006). The high volume data transmission capacity of WDP will allow full seismic wave form transmission in real-time – bringing the ability to look ahead of the bit. This ability will reduce the risk of unexpected overpressured zones and improve well placement.

3.3 Production

Full set of steering services to drill drain sections becomes available with WDP. Real-time data can be used as inputs to steering advisory systems and data-hungry geosteering applications. In conjunction with unlimited possibilities of instantaneous RSS downlinking enabled by WDP systems, it can lead to improved well placement.

Precise entry into hydrocarbon bearing formations can greatly raise production rates especially in horizontal wells and minimize water production from sands adjacent to the pay zone. Delivering smooth wellbores without hills and sags is also vital when electrical submersible pumps should be installed. As they are long and stiff, maximum dogleg severity (1 degree per 100 ft) is usually specified by the manufacturer.

WDP systems are able to manage with different drilled pay length limiters such as torque and drag (T&D), hole cleaning issues, mud pulse signal degradation, borehole instability, narrow mud window, and vibrations. Evidently, more oil can be produced with increased reservoir exposure.

3.4 Power supply

With electric power provided from the surface, downhole tools can be simpler and more cost effective. Downhole capacitors can be charged from surface.

Today, power consumption is an important criterion for most cases in order to provide a long battery life, which can result in lower performance. If there is an unlimited power supply from the surface, less care has to be taken regarding power consumption.

Another limit breakthrough is related to the time between tripping. If there is an unlimited power supply from the surface, the time of the drill string in the wellbore is unlimited. Current systems are limited to the lifetime of the battery.

Surface power supply means that the number of tools to be delivered can be reduced. Operation with batteries assumes that one tool is in the hole, the second one is standby, the third one is in the shop for battery service). If there are no batteries, only two tools are enough.

The price for batteries increases dramatically with temperature. That is why a lot of companies operate their equipment just up to 125°. One more possible application of the surface power supply is cooling, allowing to:

- reliably operate tools up to 225°C using conventional 175°C rated electronics;
- use 120°C rated automotive electronics to operate above 150°C to lower cost and expand the choice of available electronics and measurement devices.

Chapter 4 Commercial wired drill pipe systems

This chapter highlights two WDP systems. One of them – IntelliServ – is the only WDP telemetry system deployed on more than 100 wells so far. Another WDP system considered here is Powerline Drillstring. It is a state-of-the-art technology enabling not only fast telemetry, but also power supply of downhole tools. IntelliServ and PDS are compared in Table 1 in general. Two other promising systems – DualLink and Micro-repeater telemetry – are on the early stage of readiness. Another reason for being not considered in the thesis is lack of available information on these projects.

	IntelliServ	Powerline Drillstring
Manufacturer	NOV	TDE Group
Data rate, kbit/s	57	500
Power supply	No	300 W
Type of coupling	Inductive	Galvanic
Component testing	Yes	Yes
# of wells drilled	>250	1

Table 1: Comparison of IntelliServ and PDS

4.1 IntelliServ

The IntelliServ network has been under development since 1997 (Chandler et al., 2005). IntelliServ has been in commercial use since 2006. More than 250 wells have been drilled using the WDP high-speed telemetry (Foster and Macmillan, 2018).

Figure 2 shows IntelliServ telemetry system components.

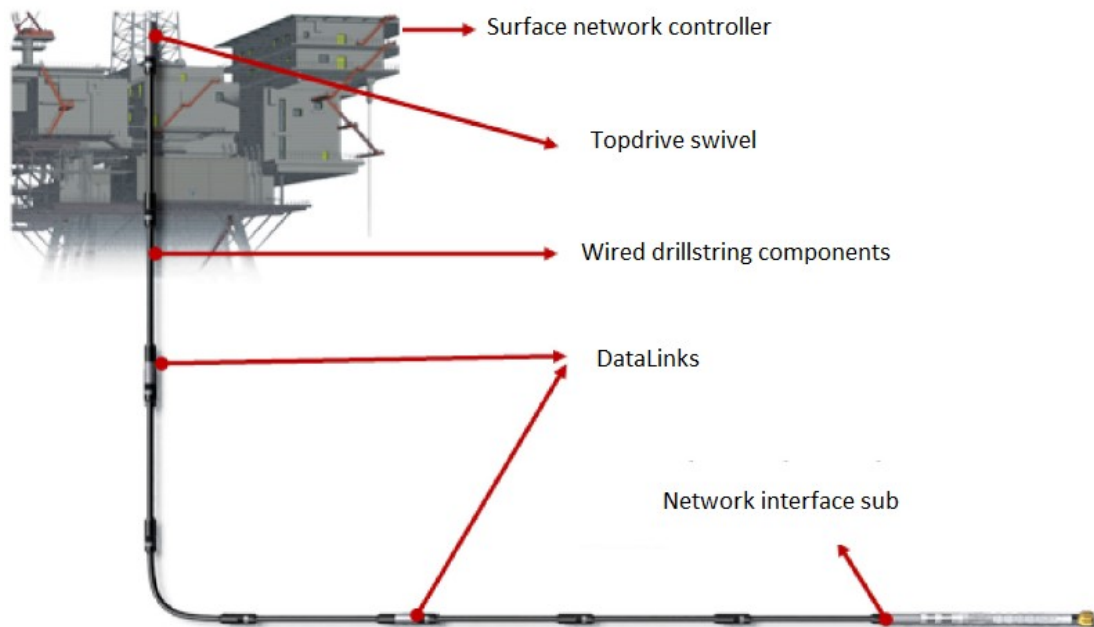

Figure 2: Wired Drill Pipe system components (Schils et al., 2016).

4.1.1 IntelliServ Version 1

4.1.1.1 Technological description

The core technology behind the telemetry drill pipe system is a passive communications link that connects discrete components together. This link includes a high-speed data cable traveling the length of each drill pipe section encapsulated within a pressure sealed, stainless steel conduit (Jellison et al., 2003). The conduit is held under tension in the drill pipe tube, maintaining its position against the tube wall and minimizing interference with mudflow or tools in the pipe center.

The conduit passes through the body of the tool joint and then enters into the internal diameter of the drill pipe at the internal upset. The cable terminates at inductive coils that are installed in the pin nose and corresponding box shoulder of every connection and transmit data across each tool joint interface (Reeves et al., 2005). Figure 3 illustrates this concept.

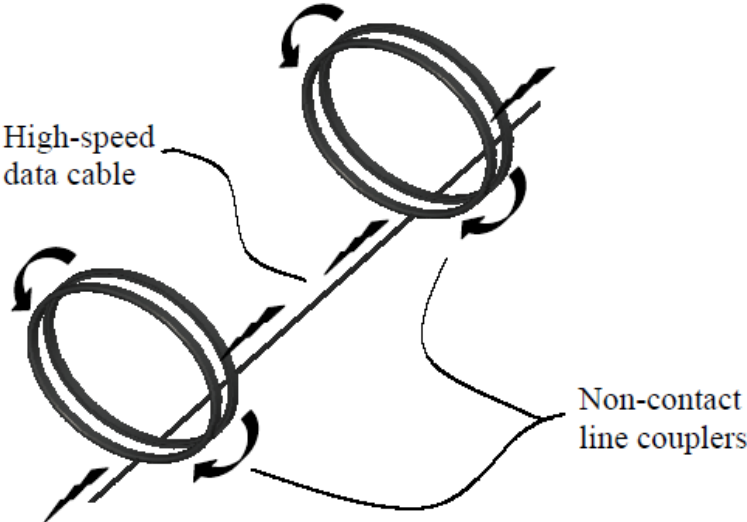

Figure 3: The non-contact line coupler uses induction to transmit data from one connection to another. (Jellison et al., 2003).

A second-generation double-shoulder tool joint configuration provides a location for coil placement. The coil is installed in a protecting groove in the secondary torque shoulder (Jellison et al., 2003).

The WDP Version 1 coil was mounted in the centre of the shoulder of the pin face (shown in Figure 4). In overtorque conditions, the double shoulder pin when flaring would then pull apart the coil and hence explain some coil cracked failures seen with WDP Version 1. With its pin coil design, Version 1 had many cases of coil breakage just while handling the pipes as this pin face is so exposed to shocks and hurts (Sehsah et al., 2017).

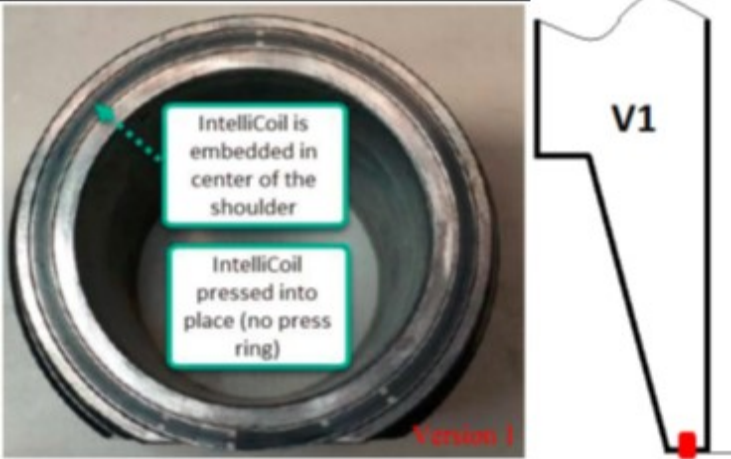

Figure 4: WDP version 1 coil mounted in the centre of the shoulder of the pin face (Sehsah et al., 2017).

As a means of minimizing power loss, the coils on either end of the connection are each placed inside a ferrite trough. Ferrite is electrically insulating in a direction parallel to the flow of current through the coil to minimize eddy current losses, and is permeable magnetically to help “capture” the electromagnetic field needed for inductive coupling. The low magnetic reluctance of this material also allows the coil to be recessed within the trough, thereby affording protection to the electrical wires comprising the coil.

Figure 5 shows a cutaway view of the communications link in a drill pipe connection. The inductive coil contains a single loop. A protective wire cover is placed atop the inductive loop within the ferrite trough. The inductive loop is connected to a coaxial data cable inside a small conduit running lengthwise through the tool joint (Jellison et al., 2003).

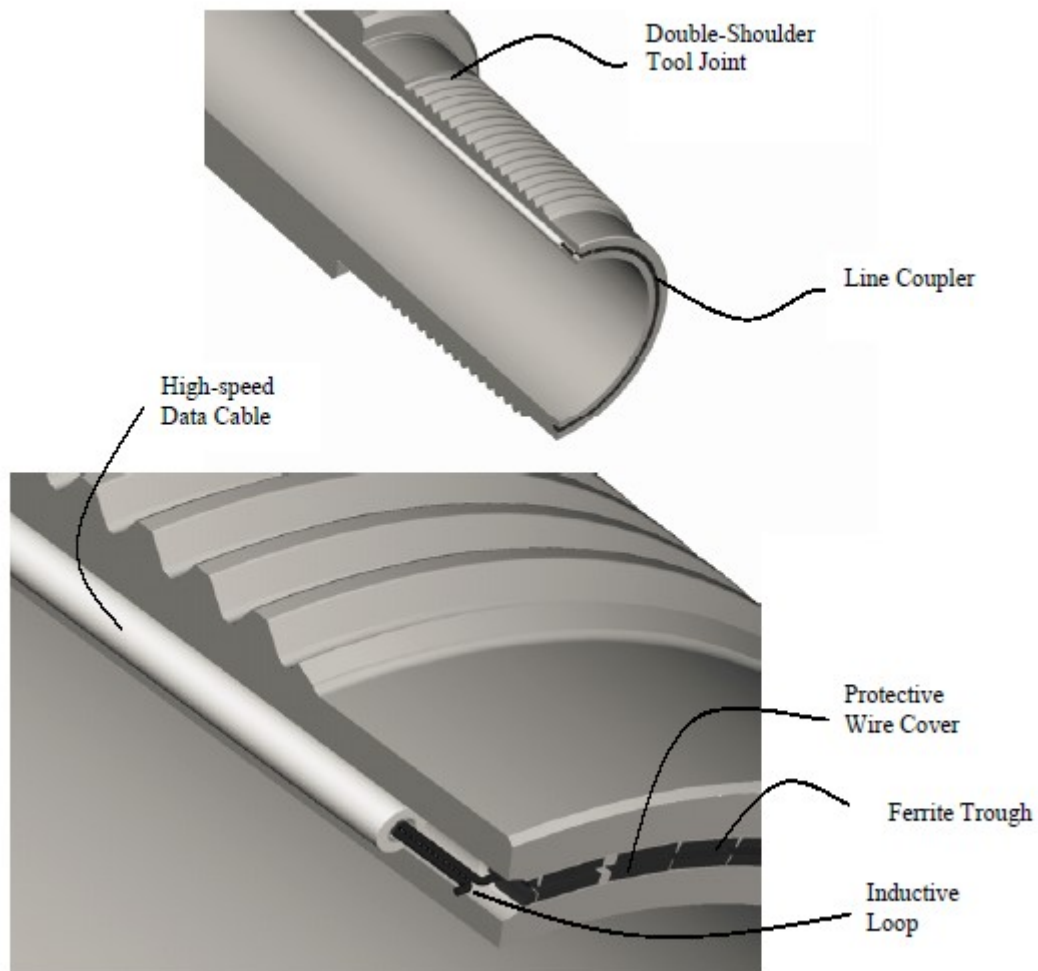

Figure 5: Cutaway view of the telemetry drill pipe system in a drill pipe connection. The inductive coil fits in a shallow groove inside the secondary torque shoulder of the tool joint (Reeves et al., 2005).

When two connections are threaded together, the pin end coil in one joint is brought into close proximity with the box end coil of another. The coils are circular in design and require no special orientation of the tool joints at make-up (Reeves et al., 2005).

A carrier signal in the form of an alternating current flowing through the coil in either segment produces a changing electromagnetic field that induces current flow in the other coil, thereby transmitting the signal to the second joint. Communication between two coils occurs passively: the coil on the sending side energizes the coil on the receiving side (Jellison et al., 2003).

When signal amplification is required, a preassembled booster drill pipe joint is inserted into the drill string. Booster joints consist of a 3 ft long sub containing an electronics

package threaded on the bottom of a specially manufactured 28 ft drill pipe joint. The full booster assembly measures 31 ft in total length and appears to rig personnel as a standard Range 2 drill pipe joint with an extended length lower tool joint. The electronics package includes a lithium battery power supply and an amplification circuit. The design can function for approximately 60 days on each set of batteries. Space also exists to house additional measurement sensors within the electronics package, enabling vibration, temperature and or pressure data to be collected along the length of the drill string at each booster location (Reeves et al., 2005).

Data can be transmitted from hundreds of distributed measurement devices, regardless of circulation conditions. Each device can be defined as a node with a unique address and can gather or relay data from a previous node onto the next. Since every node is uniquely identifiable, the location where events occur along the length of the well can be determined. Commands from the surface to devices downhole or even between downhole devices can be sent, received and acted on.

As for repair and maintenance, the Version 1 design implied to destroy the coil at each connecting repair, which made the Version 1 system hard to maintain on location and expensive to own (Sehsah et al., 2017). If shoulder or thread damage occurs, the inductive coil would be removed, the connection – recut, a new groove – machined and a replacement coil – then installed. The presence of the groove within the secondary shoulder prevents refacing of any intelligent connections. No changes to the conduit are necessary during recut operations.

Heavy weight drill pipe, drill collars, drilling jars, string stabilizers, roller reamers and other accessories machined with double shouldered connections have all been modified to support the network (Reeves et al., 2005).

Wired heavy weight drill pipe and drill collars employ a design that is similar to the drill pipe configuration with a protected high speed data cable running the length of the joints terminating at data couplers installed in the shoulders of the pin and box connection members. Heavy weight drill pipe utilizes the same connection designs as standard drill pipe.

The accommodation of jar firing movement without damaging the data communication circuit presented one of the most significant intelligent drill string technical challenges. A design that incorporates a coiled spring conduit that encases and protects the high-speed data cable was developed to permit the data cable to move with the drilling jar.

A top drive swivel sub is used to pass the data signal from the rotating drill string to a surface data acquisition system, see Figure 6. This sub is placed between the top drive and the top joint of drill pipe in the string.

When installed, a chain or wire rope restraining device is used to hold a ‘floating’ swivel ring on the sub outside diameter stationary, providing a fixed location for the attachment of a heavy-duty data cable. This cable in turn connects the swivel sub to a surface acquisition computer system.

The top drive sub provides data transmission performance that is comparable to the tool joint pin/box coupling.

The lower pin connection of the top drive swivel is subject to a greater number of stabbing, make-up and breakout cycles than any other drill string connection, as a result, a unique coil design has been implemented to allow rapid rig-floor change out of this coil in the event of damage (Reeves et al., 2005).

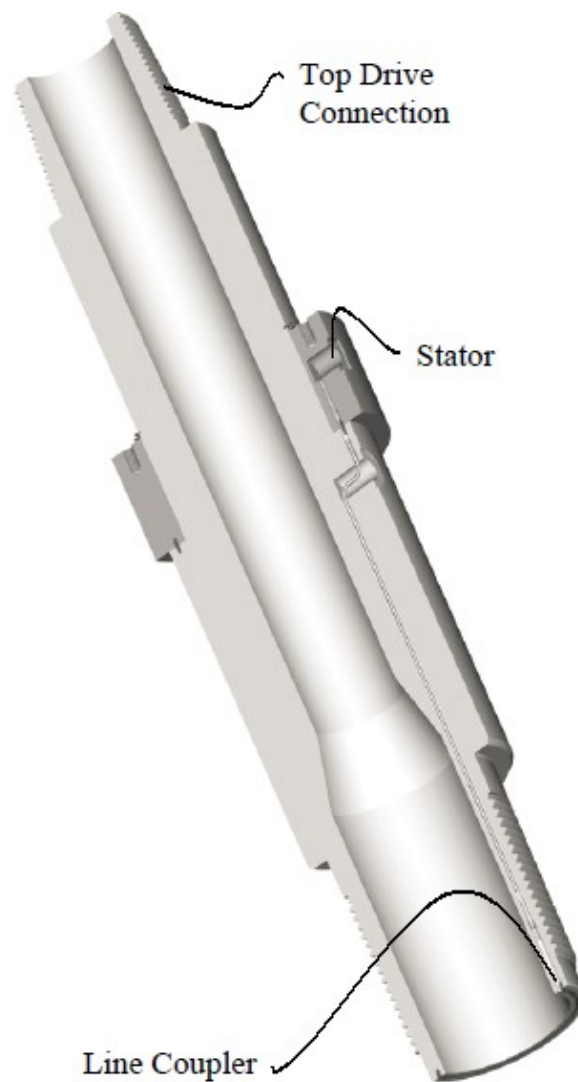

Figure 6: A top drive sub provides a communication link between the rotating drill string and a data acquisition system (Jellison et al., 2003).

4.1.1.2 Major problems experienced

Most of reliability problems in the deployment of IntelliServ Version 1 were associated with connections. There were few mechanical issues with the wired pipe itself or the wiring. Major issues experienced are described below.

4.1.1.2.1 Corrosion

Many of the pipe joints used in the North Sea deployment had previously been used in Norway and were stored for over a year prior to deployment to the platform. During that time the flarel (the component that is embedded within the tool joint and connects the coil to the coaxial cable) which was at the time made of steel, had corroded. When

the pipe was run in the hole to a certain depth (pressure), the network became intermittent or completely failed. In the end, steel as flarel material was changed to a new, corrosion-resistant one (Edwards et al., 2013).

During a WDP deployment using exceptionally high mud chloride levels, the networked drill string armored coaxial cable experienced stress corrosion cracking. Additional mechanical stress triggered several armored coaxial cable failures. None of the armored coaxial cables detached from their pipe, and all of the joints remained mechanically serviceable as pipe only, but removals required significant downtime and NPT. Also, on a batch of pipe in Trinidad, stored between jobs without being cleaned of the drilling fluid, stress corrosion cracking occurred. These incidents triggered a materials review which inspired a subsequent design change (Edwards et al., 2013).

4.1.1.2.2 Downhole over-torquing of connections causing damage to coils

At the end of the second well drilled in Trinidad the string was being used during completions. Because of the concern for contamination of the completion fluid, the connections were not doped while being made up (correct approach would be a light doping). The string became stuck and then was over-torqued which caused deformation of the milled groove in which the coil is recessed. On subsequent wells, more attention was paid to ensuring proper doping, top drive settings and drilling practices to minimize the risk of over-torquing (Edwards et al., 2013).

4.1.1.2.3 Damage to coils caused by pipe handling on make-up/breakout

The general rule is that wired pipe requires no special handling procedures on make-up and breakout. However, while you can get away with not using good pipe handling procedures with non-wired pipe, the same “bad practices” with wired pipe could easily lead to damage of the coils and network reliability issues. Misstabbing on making up connections is the commonest cause of damage. The coil in the pin end of the upper joint can hit the edge of the box end with some force. Further damage can then be caused by the practice of rotating the joint to encourage it to drop into place, while the pin end of the upper joint is still resting on the rim of the box end of the lower pipe. Similarly, when racking back, the pin end coil can be damaged if it is “dropped” onto the rig floor prior to being placed on a drill pipe mat (Edwards et al., 2013).

4.1.1.2.4 Top drive issues

The coil on the end of top drive saver sub sees more connections than any other coil so it is most susceptible to damage. It is better to have spare wired saver subs to hand and a top drive that is easy to change the saver sub. The cabling around the top drive area can also be an issue. Having back-up cables help mitigate this issue (Edwards et al., 2013).

4.1.1.3 Reliability metrics

The WDP system is being considered as a single entity. This approach gives an overall solid picture of network drill string reliability under a variety of downhole conditions.

Mean Time Between Failure (MTBF) is one metric used in the industry to measure reliability. MTBF trends are analyzed and compared with trends of other metrics to obtain a picture of historical network drill string performance.

Uptime and non-productive time (NPT) are two metrics historically used to assess the reliability of networked drill strings (Veeningen et al., 2012). Uptime is defined as the possible data hours during a run or hole section that network drill string was functioning divided by the total time the drill string was operating.

This metric alone is not sufficient to give the full picture and often needs to be qualified. In some cases, the network uptime alone can look deceptively good. For example, on one particular run, the network may have a 90% uptime, but it may have taken many hours of flat time to fix the network issues to enable such a good uptime. In other cases, the network uptime can be deceptively poor. For example, there are times when during a BHA run, an early failure occurs towards the bottom of the string. If the decision is made not to trip out to fix the problem, the network is down for the rest of the run so as a result of one network break the uptime maybe only a few percent.

NPT is an associated reliability metric that should be viewed in conjunction with network uptime. In the context of the networked drill string, this metric is defined by the total time required to address network interruptions.

MTBF may be calculated from historical data as the sum of the total operating hours divided by the total number of service interruptions (McCubrey et al., 2013). Operating hours consist of drilling, reaming and circulating hours.

The data and most conclusions below are based on a reliability study from 65 wells that were drilled from 2008 to 2011 (McCubrey et al., 2013).

Figure 7 provides a consolidated view of WDP reliability metrics (NPT, uptime and MTBF) through a series of commercial deployments. The figure demonstrates a pattern of increased reliability. The trend follows from a series of operational challenges, followed by reliability and durability improvements. The figure highlights these operational challenges as letters surrounded by ellipses with more detail on challenges and network improvements beneath the graph.

Commercial wired drill pipe systems

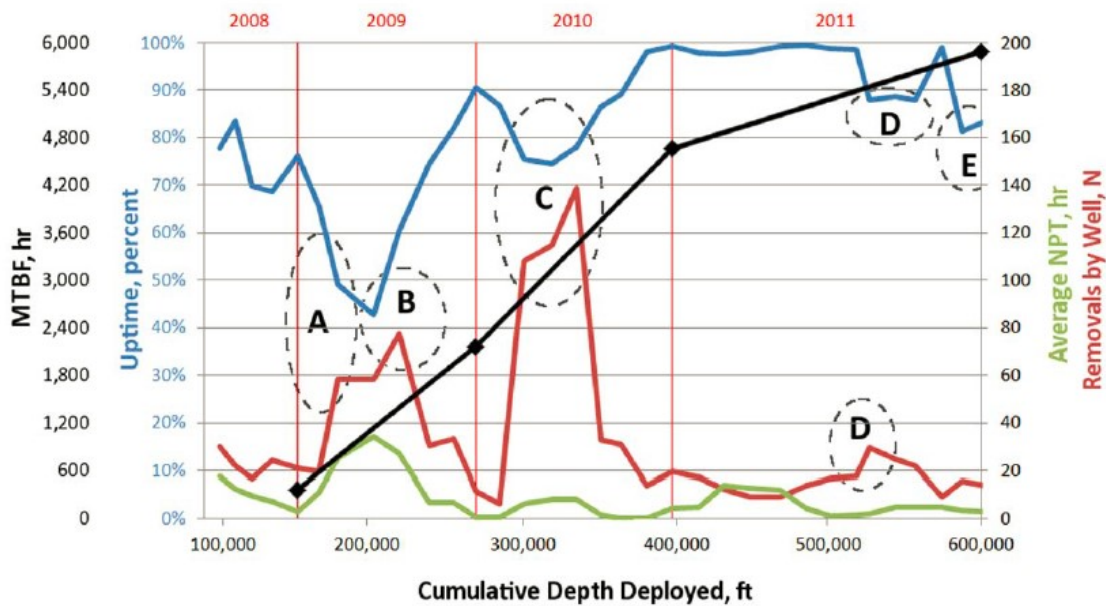

Figure 7: Graph of network drillstring uptime, average NPT, and MTBF over commercial deployments in the period 2008-2011 (McCubrey et al., 2013).

According to McCubrey et al. (2013), operational conditions and improvements are labeled on Figure 7:

(A) Corrosion of steel flarels

(B) Stress corrosion cracking

(C) Over-torqueing of connections

(D) Even while reliability increased, the networked drillstring has suffered from additional stress corrosion cracking incidents during long-term storage after incomplete cleaning, and from aerated mud with additional high-dogleg stress. The design change was completed, and the revised armored coaxial cable material was thoroughly field testing in a high-dogleg environment during 2011, where the design change proved itself for reliability and durability.

(E) Severe miscalibration of an iron roughneck led to torsional damage to the WDP tool joints, which affected service reliability.

The WDP reliability has climbed steadily as string components integrate lessons learned from the field experience (McCubrey et al., 2013), however the industry admitted that IntelliServ Version 1 had several intrinsic issues which could not provide required degree of the overall reliability.

4.1.1.4 Summary of the campaigns

More than 100 wells in 24 different drilling campaigns have been drilled with IntelliServ Version 1 system. A summary of these campaigns, including number of wells, footage drilled, and well depths, is given in Table 2. Figure 8 graphically illustrates the regions and types of wells on which WDP has been deployed. More than 1 million feet of formation have been drilled with first-generation wired drill pipe.

#	Campaign	Location	# of wells	kft drilled	Max. MD, kft
1	Arkoma	N America Land	7	84	14
2	Wild River	N America Land	23	228	11
3	Myanmar	Asia Pacific Offshore	1	1	3
4	Troll Field	North Sea Offshore	2	19	16
5	Wamsutter Field	N America Land	2	27	14
6	Visund Field	North Sea Offshore	1	5	16
7	Tabasco	Latin America Land	7	11	21
8	Elk Hills A	N America Land	12	82	9
9	Elk Hills B	N America Land	5	26	7
10	Van Gogh	Asia Pacific Offshore	4	63	13
11	Elk Hills C	N America Land	5	45	10
12	Trinidad	Latin America Offshore	10	124	17
13	Magnus Platform	North Sea Offshore	2	33	23
14	Asia Pacific	Asia Pacific Offshore	2	4	16
15	Capiagua Field	Latin America Land	1	13	17
16	Atlantis Field GOM	N America Offshore	2	11	19
17	Babbage Field	North Sea Offshore	2	11	15
18	Granite Wash	N America Land	14	78	18
19	Brazil	Latin America Offshore	2	19	18
20	Marcellus	N America Land	7	60	16
21	North Sea B	North Sea Offshore	8	110	18
22	Eagleford	N America Land	3	40	15
23	Goliat	Barents Sea Offshore	5	12	9
24	Eagleford	N America Land	2	41	20
Σ			129	1148	

Table 2: Summary of Well Campaigns IntelliServ Version 1 WDP (as of November 2013) (Craig and Adsit, 2014)



Figure 8: Location of wells drilled using IntelliServ Version 1 (offshore – blue, land – brown) (Craig and Adsit, 2014).

4.1.2 IntelliServ Version 2

Several improvements have been made to the basic design of IntelliServ telemetry components, yielding a second generation wired drill pipe system. Areas of focus for the improvements include each of the major systems in the drill string network: the wired drill pipe itself, the downhole network electronics, and the surface network control electronics.

4.1.2.1 Lessons learned from Version 1

In a series of wells, the majority of reliability-related incidents involving the telemetry system were found to be associated with the drill pipe connections (Edwards et al., 2013). Intrinsic durability of system components could be improved. Dropping of drill pipe stands onto their secondary shoulder while handling on the rig floor, stabbing problems, and overtorque issues contributed to connection damage. Such damage can also affect the wiring components and impact the performance of the data network. Some of these issues were not fully resolved by operational improvements alone (see Lawrence et al., 2009).

Special equipment and skill sets have been required to perform certain redress operations on wired pipe connections (Veeningen et al., 2012). This increases the expense of redress and presents more limited options to the telemetry service provider when considering repair logistics, especially in the context of a worldwide industry.

Stress corrosion cracking of the armored coax was encountered in applications where water-phase salinity levels were not expected to yield such corrosive attack. Analysis of these incidents has found varying causes, including most notably storage conditions and cleanliness, followed by mud emulsion issues and high stress conditions. While procedural changes have been put into place, design improvements can further decrease component sensitivity to operating and handling conditions.

Telemetry interruptions related to downhole network circuitry failures have been encountered in some deployments. These issues have pointed to needs for improvement in the design of network control devices.

In some cases, where telemetry system faults have occurred, the fault did not persist, leading to intermittent service quality and difficulty pinpointing the faulty component. These cases have underscored need for improved diagnostic methods.

Application of multiple sensors in positions along the drill string has highlighted the need for better absolute accuracy of sensors, to reduce post-processing effort required to understand data quality and their implications (Coley and Edwards, 2013).

Table 3 shows areas for IntelliServ V1 improvement and corresponding modifications implemented with Version 2.

Area for improvement	Modification implemented with Version 2
Torsional strength	20% higher torsional capacity
Connector position and actuation	Proud box-end coil and recessed pin coil, mounted on the ID of the connection
Corrosion cracking	Corrosion resistant alloy UNS N08825
Redress operations	Field replaceable inductive coils
Downhole electronics	Increased diagnostic capabilities, new battery controller
Surface electronics	Graphical user interface

Table 3: Modifications implemented with IntelliServ Version 2

4.1.2.2 Wired drill pipe improvements

First, the connection itself has been strengthened to better address growing torsional requirements. Third-generation commercially available double-shouldered connections (Figure 9) have been fitted with wiring components, improving torsional capacity by at least 20% over the high torque connections that were wired in the past. In an effort to further strengthen these connections, the wired versions of these high-torque connections have been thickened to compensate for lost bearing area due to the presence of the wiring components. This thickening results in a slightly smaller inside diameter and larger outside diameter for the tool joint, but creates a recommended make-up torque (RMUT) that is identical to or slightly exceeding the standard unwired connection in that size range.



Figure 9: Third generation double-shouldered connection (Craig and Adsit, 2014).

Second, recognizing that aggressive drilling conditions may sometimes lead to operation of a tubular outside of specification, the wiring components embedded within the connections have been redesigned to make the system more tolerant of overtorque events. Previous inductive connectors were spring-actuated towards their mating connector via a tapered surface in the end of the tool joint (Figure 10). This biasing method required elastic stretching of the connector when actuated, which sometimes led to overstressing of the connector if the tool joint deformed due to overtorque. To mitigate this failure mode, a different spring actuator is used in the second generation inductive connector which does not rely on elastic stretch of the connector (Figure 11). Electrical wiring within the inductive connector is no longer subject to mechanical straining due to the biasing process; thus, fatigue failure is less possible.

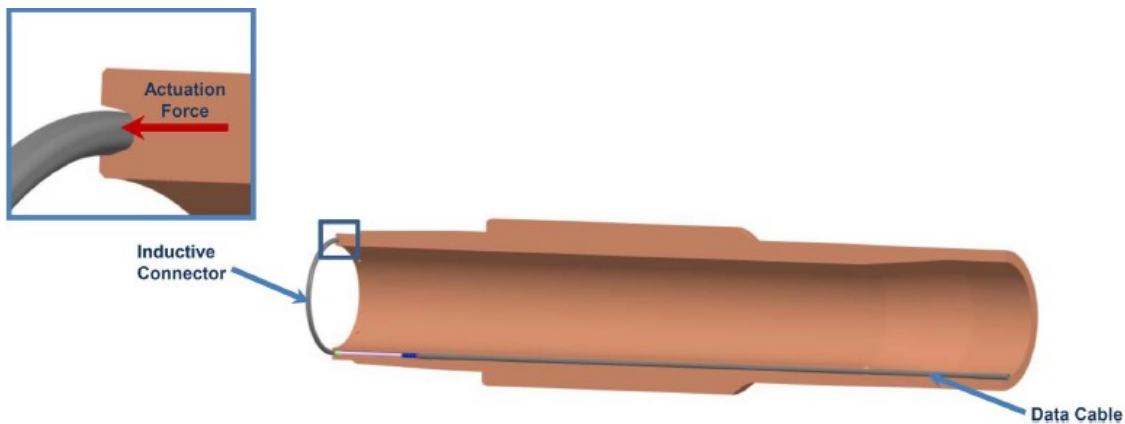

Figure 10: Basic configuration of WDP (Craig and Adsit, 2014).

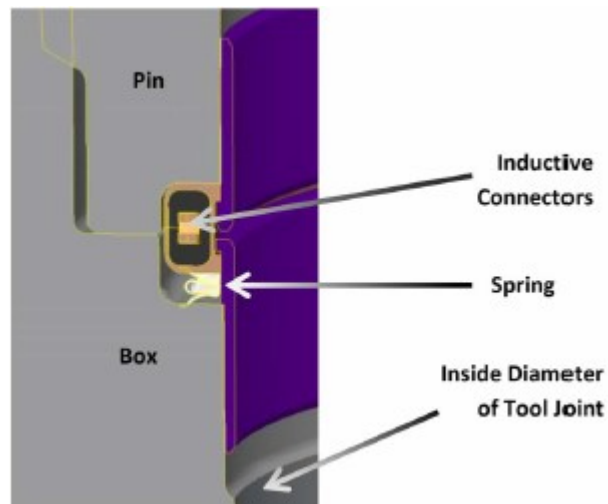

Figure 11: Modifications of inductive connector position and actuation (Craig and Adsit, 2014).

The WDP Version 1 coil was mounted in the center of the shoulder of the pin face (shown in Figure 4). In overtorque conditions, the double-shoulder pin when flaring would then pull apart the coil and explain number of the coil cracked failures seen with WDP Version 1.

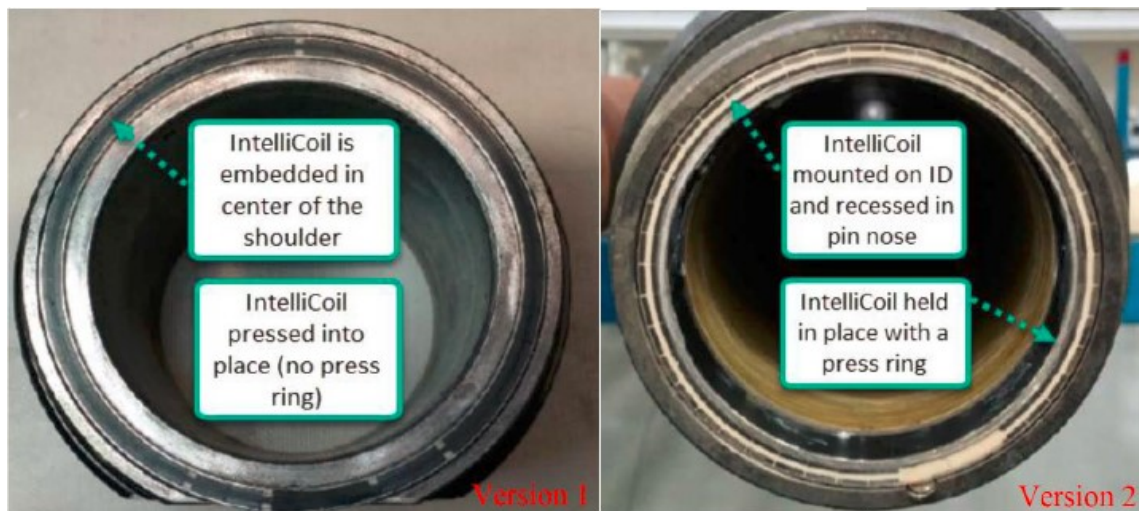

Figure 12: On the left – WDP Version 1 coil. On the right – WDP Version 2 (Sehsah et al., 2017).

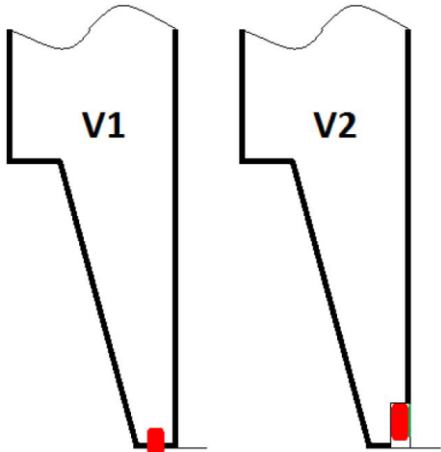

Figure 13: WDP Version 1 vs Version 2 coil placement (Sehsah et al., 2017).

The WDP Version 2 coil is now mounted on the ID of the connection pin, bringing two improvements (Fig. 12 and 13). First, the coil will not be pulled along in case of flaring action. Another improvement is that the pin coil is more protected from handling damages.

The new connector withstands more wear, robust cleaning, or abuse. The improvements are demonstrated in Fig. 14. Previous inductive connectors used an acceptable filler material suitable for routine rig environmental conditions. Second generation inductive connectors use a filler material selected and tested for superior resilience and adhesion. The results in Fig. 14 are from a heated high-pressure spray directed at the coil face from a controlled distance of 1". The previous inductive connector received catastrophic damage, while the second generation had no damage.

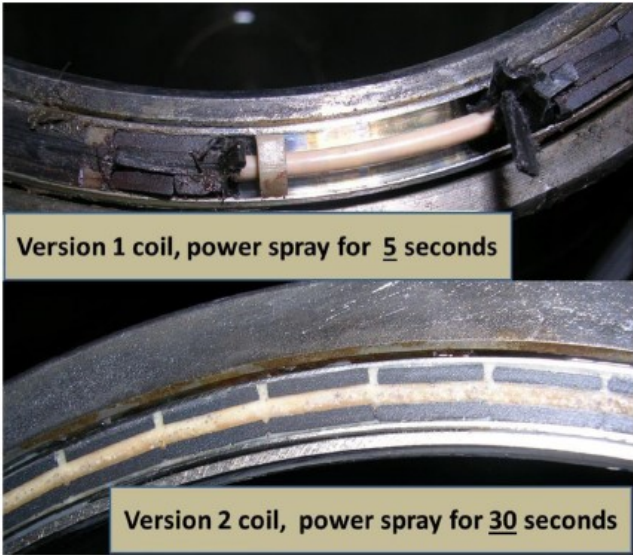

Figure 14: Second generation coil is much more durable (Craig and Adsit, 2014).

Finally, the Version 2 coil is field removable and replaceable (Figure 15). Thanks to this clip system, the Version 2 coil can be removed at location before machining and be replaced after machining. This means that the WDP Version 2 is easier and cheaper to maintain on site.



Figure 15: WDP version 2 designed to be field removable and replaceable (Sehsah et al., 2017).

The corrosion cracking issue was resolved by use of corrosion resistant alloy UNS N08825.

4.1.2.3 Improvements to downhole network electronics

According to Craig and Adsit (2014), WDP Version 2 includes noise monitoring and management functions, increased diagnostic capabilities and a more robust recovery routine that facilitates faster reestablishment of network connectivity following a disconnection.

A “smart” battery controller has been added to the system. This controller monitors individual battery pack voltage, power consumption, and time/temperature conditions, and provides for load testing. This leads to longer and more reliable battery performance.

A level of access to the network by third party tools grew up. This provides for lower level integration of such tools into the network. Additionally, auxiliary power is now available for use by partner tools. These improvements facilitate network connectivity.

4.1.2.4 Surface electronics improvements

The second generation drill string network includes a graphical user interface. It includes graphical icons with color codes and numerical data that give an operator a simple view of overall network status at a glance. He may then obtain more detailed information regarding potential problems or actual network faults by drilling down to detail screens via intuitive touchscreen actions (Craig and Adsit, 2014).

4.1.2.5 Anticipated benefits from IntelliServ Version 2

The following benefits are anticipated from the second generation IntelliServ:

- increased system reliability that will meet growing requirements for data integrity;
- lower cost of ownership to make the system economically feasible for a wider range of drilling operations;
- improved network connectivity for programmable/controllable tools;

Commercial wired drill pipe systems

- faster learning for network monitoring and administration functions (Craig and Adsit, 2014).

4.1.3 Feedback from service companies

4.1.3.1 Early feedback (2003 – 2006)

According to Jellison et al. (2003), IntelliServ system is transparent to standard rig procedures. Reeves et al. (2005) added that no special handling or make-up procedures are required and any thread compound chemistry can be used.

IntelliServ offers robust operation (Jellison et al., 2003) with reliability comparable to current MPT technology while bringing little risk to the drilling process (Reeves et al., 2006).

4.1.3.2 Wamsutter field campaign

Ali et al. (2008) described the first deployment of a IntelliServ network with a rotary closed loop system and triple combo suite in North America. Some of the feedback is given below:

- IntelliServ network is compatible with the latest drilling and MWD/LWD technologies.
- Real-time memory-quality drilling dynamics data helps responding to downhole dysfunctions instantaneously which leads to higher drilling efficiency and wellbore stability.
- Real-time high resolution gamma/density images and formation evaluation data facilitate in assessing reservoir potential on the fly.
- The real challenge in utilizing the full potential of this technology lies in managing the high volume of downhole information available real-time.

4.1.3.3 Trinidad campaign

Extended reach offshore wells in Trinidad & Tobago were characterized by wellbore instability and hole cleaning challenges.

The solution to these problems was found through advanced downhole measurements of borehole stability and hole cleaning, transmission of those data back to surface via a wired drill-pipe, deployment of subject matter experts into the rig team for critical phases of the operation, and decision-making to mitigate the problems.

The methodology involving combination of the WDP technology, field deployment of subject matter experts, and amended drilling practices was implemented on the third well, resulting in a reduction of NPT from 47% and 48% on the first two wells, to 10% on the third (Veeningen, Fear et al., 2012).

4.1.3.4 MPD with WDP in Mexico

Rasmus et al. (2013) explain how WDP telemetry helps to establish bidirectional communication while drilling with nitrified mud.

Annular downhole and ASM pressure-while-drilling measurements were received continuously at the surface via WDP, which allowed for directional control as well as for calibration of the multi-phase hydraulic simulator for proper assignment of the surface back pressure.

With WDP, downhole data is actively transmitted during the time between pump shut-down and pipe disconnection. This allows MPD personnel to monitor actual annular pressure during pump transitions and more accurately determine the optimum choke position for constant BHP.

Rasmus et al. (2013) concluded that MWD/LWD data delivered via WDP are the best option to obtain high-frequency and high-resolution data from downhole tools, in a low-liquid/high-nitrogen-injection rates environment, when low ECDs are encountered.

4.1.3.5 Babbage field campaign

Teelken et al. (2016) describe how IntelliServ was deployed on two wells of the Babbage development project during Phase I.

The implementation of the WDP network allowed for:

- Actual telemetry time savings of 1.1 day/well
- Optimum trajectory control and improved wellbore placement enabled through
 - real time LWD image logs and improved understanding of the real time downhole drilling environment,
 - detailed downhole vibration and ECD data, in combination with the use of a downhole powered RSS system
- Bit/BHA trip time reduction. For the WDP wells, less bit/BHA runs were required to reach the target depth. During drilling of the two WDP wells only one downhole tool failure was encountered, whereas during drilling of the three MPT wells, six downhole tool failures were encountered.
- Increased drilling performance for every section: ROP increase ranging from 100% to 200%.

Overall, multiple days per well were saved due to the combination of the telemetry time savings, ROP improvements and trip time reduction.

4.1.3.6 IntelliServ Version 2

According to Foster and Macmillan (2018), improved reliability of WDP V2 now provides uptimes of 98%.

Engineering changes also reduced the total cost of ownership by enabling and leveraging in-place facilities to perform rework and maintenance.

4.1.3.7 Summary of feedback from service companies

The early feedback from IntelliServ reported on high reliability and transparency to rig procedures. Though a lot of engineering issues were revealed later, the manufacturer did not pay much attention to this in the publications, but emphasized the benefits which can be gained as a result of IntelliServ data analysis. The papers released by service

companies look like advertisements aiming at demonstration of the best IntelliServ field experience.

4.1.4 Feedback from operators

4.1.4.1 Troll field campaign

Two laterals of an extended reach well were drilled with IntelliServ telemetry in 2007. This campaign is discussed by Wolter et al. (2007). The technology deployment satisfied all involved parties with the following key performance indicators:

- The telemetry drill string data delivery system should be at least 95% operational. Actual performance was 90% operational over both laterals.
- The ability to switch between WDP telemetry and MPT without the need for a trip to surface was demonstrated with success ratio = 100%
- Memory quality data were delivered to surface from the downhole measurement tools via the drill string telemetry network with success ratio = 100%
- Instantaneous control of downhole RSS tools with success ratio = 100%
- The ability to handle a continuous real-time data stream of 10 kbit/s with success ratio of 75%.
- Well-site handling and robustness of the WDP telemetry components must be comparable with existing non-telemetry drilling tubulars. The rig team and operator assigned a success ratio of 100% to this category.
- Overall tripping and pipe handling time for telemetry tubulars did not exceed 120% of the time normally expected for non-telemetry tubulars.

4.1.4.2 Visund field campaign

Results of Visund drilling campaign using WDP to operate and transmit data with high resolution are described by Lesso et al. (2008).

The most obvious and immediate benefit of WDP technology was in the areas of fast downlinking and two-way communication with the new generation of MWD, directional and LWD tools. High-frequency time-based data were also useful for real-time torque and drag analysis and borehole quality analysis using real-time caliper data. Better monitoring of downhole formation and wellbore pressures provided a basis for improved well control and borehole stability. The ability to view more curves with higher resolution enhanced the well placement/geosteering process.

The failure of one component in the WDP transmission after 500 m of drilling also highlighted the vulnerability of the system. IntelliServ technology was admitted to be still at an early stage. Lesso et al. (2008) concluded that back-up MPT should continue to be run until IntelliServ technology matures.

4.1.4.3 Van Gogh field campaign

Lawrence et al. (2009) in their paper dedicated to the deployment of IntelliServ for Offshore Australian Van Gogh field put emphasis on two important points:

- The most frequent problem encountered with the wired drill pipe was the damage to the induction coil at the pipe connections. This problem had never been fully rectified and was still under review.
- The top drive required modifications to the swivel to allow the signal to be fed from the drill string to the surface data acquisition system. Sufficient lead-time must be provided prior to a project start-up to allow any modifications to be designed, installed and tested with the specific rig equipment.

4.1.4.4 Elk Hills field campaign

McCartney et al. (2009) describe the deployment of IntelliServ telemetry at Occidental of Elk Hills in California.

Improvements achieved in this project were:

- ECD management enhancements;
- vibration diagnostics for drilling optimization;
- instantaneous downlink commands to RSS;
- elimination of data linking related NPT;
- directional control improvements;
- memory quality formation evaluation measurements which allowed for more effective reservoir navigation and wellbore placement.

The risk associated with the implementation of the wired-pipe was found low. Overall, well construction was 10% faster with WDP (McCartney et al., 2009).

4.1.4.5 Babbage field campaign

Hatch et al. (2016) describe how IntelliServ was deployed on two wells of the Babbage development project during Phase I.

The implementation of the WDP network and the use of an RSS ensured optimum trajectory control, ensuring “sweet” spots were identified and delivered, while maintaining 3 times higher ROP.

By using the increased data-carrying capability of the WDP, it was possible to provide high quality image data, allowing a better understanding of the downhole environment and ensuring the stratigraphic control. Improvements in reservoir quality (increased porosity) and quality (twice increased net-to-gross) have been achieved (Hatch et al., 2011).

4.1.4.6 Martin Linge field campaign

According to Schils et al. (2016), main advantages and opportunities that resulted from the implementation of IntelliServ telemetry on the Martin Linge development were:

- Telemetry time savings ~ 1 day /well
- ROP continuously improved in time, creeping towards the constraint of 20 m/hr
- An average uptime of IntelliServ network was 93%.
- Network maintenance time was tracked and decreased throughout the project, to ~ 4.8 hours /well
- New technologies were implemented during the project saving rig time:

Commercial wired drill pipe systems

- Integrated reamers (main and near bit reamer activation through WDP)
- Seismic while drilling (activation and data transfer through WDP)
- Geosteering was optimized with real time memory quality formation evaluation and drilling dynamics data which resulted in:
 - Improved wellbore placement
 - Increased reservoir section length of ~1000 m
 - Optimized sand exposure from an average expected value of 67% to 81%.
- ASM readings proved valuable for understanding and management of ECD when drilling the horizontal drains.

The ‘net’ time savings per WDP well and for the total Martin Linge Project are summarized in Table 4.

	Time savings per well, h	Time savings per project, h	Time savings per project, days
Telemetry time	25	275	11.5
WDP network maintenance time	-4.8	-52.8	-2.2
CAPEX			-4
Spread rate increase			-1
Min „net“ time savings			4.3

Table 4: Overview of ‘net’ time savings per well and for the project (Schils et al., 2016)

WDP was presented as a part of a wider intelligent drilling system that will perform as a risk management tool in Sehsah et al. (2017). With such system, detection of fluid level and early downhole kick detection is now possible in total losses situations.

Furthermore, IntelliServ Version 2 (globally used since 2015) is an improved WDP network from reliability and ease to maintain perspectives.

The reliability achieved by the WDP in this project comes close to MPT tools from an electrical integrity and data continuity side. Moreover, the WDP is as reliable as conventional drill pipe from a mechanical integrity point of view (Sehsah et al., 2017).

4.1.4.7 Summary of IntelliServ in BP

Edwards et al. (2013) released a paper reporting on the benefits and issues of running the IntelliServ drillstring on 10 wells in five different locations within BP during an evaluation period between 2007 and 2010.

The authors noted a whole range of new possibilities related to WDP telemetry which enable greater visibility of what is happening downhole. IntelliServ enables advantages in areas of:

- wellbore stability,

- wellbore placement,
- hole cleaning,
- shock and vibration management,
- drilling optimization,
- annular pressure monitoring,
- downhole tool control,
- LWD formation pressure testing,
- downhole tool reliability,
- ASM.

Edwards et al. (2013) marked that at least 6 months was required in the deployments to accommodate the modifications without creating excessive downtime on critical path.

They also emphasized on importance of fruitful interaction between all involved parties. The operator needs to take the lead to ensure coordination between the wired pipe provider, measurement provider, rig contractor and other 3rd parties. Operators who are able to approach use of wired pipe as a project, in partnership with the providers (not as a call out service) and who are flexible enough to adapt their workflows to capitalize on full two-way connectivity, stand to be at an advantage in drilling.

The experience from the initial implementation of WDP V1 which ran from ~ 2004 to 2012, in four different operating regions, allowed BP to conclude that while there was benefit from the improved data bandwidth and speed that the system provided over MPT, the overall reliability did not meet business and operational requirements (Israel et al., 2018). Edwards et al. (2013) saw a number of opportunities for improving the reliability in the aspects of:

- the intrinsic design of the pipe;
- pipe handling procedures;
- maintenance application

The WDP V2 has proven to have a higher reliability over the previous generation. But there is still a lack of software applications for the real time analysis of data available from this IntelliServ, especially in support of the distributed measurements (Israel et al., 2018).

4.1.4.8 Summary of feedback from operators

In general, operators try to consider IntelliServ in all its aspects. They do not hesitate to mention reliability and handling issues. It is a common practice to establish KPIs in advance which introduces more objectivity into post-well analysis. Some companies not only express their conclusions qualitatively, but also present quantitative time and cost analysis, calculating an overall effect of IntelliServ implementation.

Among the many papers considered, there were no negative feedback on the WDP technology. On one hand, it is possible to assume that each company used Intelliserv has succeeded. On the other hand, it might be the case that if a fail had occurred, no publication followed.

4.1.5 Why IntelliServ has not made a market breakthrough

Wired drill pipe has been in commercial use since 2006. More than 250 wells have been drilled using the WDP high-speed telemetry. But the total number of wells drilled for the same period is several orders of magnitude higher. Although WDP technology was found promising by NOV, it has not made a market breakthrough.

Some companies still consider the drill string only as an intermediate component between the surface and the bit which transmits rotation and serves as a channel for mud circulation. Many others are interested in getting information from downhole, but are satisfied with data rates available with MPT.

Finally, there are companies which find applications enabled by WDP attractive. But the first point that can stop further discussions about WDP for them is that WDP itself is not an answer product. This is just a high-speed “transmission line”. Now they are able to get more information, but they cannot use it properly.

There are a lot of possible bottlenecks on this way: lack of processing equipment on the drilling site, issues with sending the information stream to a remote support center, or this center can be absent at all. Probably, there is no appropriate software to handle the expanded data. Furthermore, suitable and competent analysts are required to make decisions based on the new information.

WDP is not a call-out service. Its implementation may be realized only in close interaction of all involved parties: the field operator, the WDP service company, the drilling contractor, LWD/MWD tools providers, the software provider and, finally, the drilling crew. Sufficient lead-time (up to one year) must be provided prior to a project start-up to allow any modifications to be designed, installed and tested with the specific rig equipment and organize the WDP technology deployment properly.

WDP is not fully transparent in normal daily rig operations, because WDP is available only in the suite with certain pipes and tool joints. For example, rig crew members should be familiar with double-shouldered connections handling procedures. WDP brings new equipment and operations into the rig site. Thus, people working there should be acquainted with the innovations in advance. Otherwise, unexpected failures related to human factor are likely to occur.

Evidently, there are fixed costs and variable costs related to WDP implementation. And the more scale of the project is, the more beneficial it should be. In other words, the company which will be able to include the concept of WDP telemetry into its regular drilling activity will eventually go great guns. But in the meantime with higher scale, the severity of consequences in case of failure ascends.

One very important limitation for the first generation of WDP was the system reliability. BP being the leader in WDP deployments concluded that the overall reliability of WDP V1 did not meet business and operational requirements. (Israel et al., 2018)

Both NOV (Foster and Macmillan, 2018) and operating companies (Sehsah et al., 2017; Israel et al., 2018) confirm improved reliability of WDP V2. But the number of available data regarding reliability metrics of the second-generation WDP is not sufficient to use statistical approach and confidently assess related risks.

Finally, there is no universally accepted methodology for quantified comparison of time and cost savings resulted from WDP use with correspondingly growing costs.

Due to all abovementioned reasons, WDP technology has not made an industrial breakthrough, but still is promising for the future and waiting for further feasibility studies.

4.2 Powerline Drillstring

This section contains basic information³ on PDS functionality, power supply features, and PDS test results.

4.2.1 System structure

TDE Group as the manufacturer declares that PDS can transfer power (300 W) along the string and data (500 kbit/s) simultaneously at any time during drilling, tripping and when the drill string is hanging in the slips without connection to the top drive. Connection during tripping and hanging in the slips is enabled by a tripping sub. It is a device which connects electrically to the drill string when the drill string is hanging in the elevator or in the slips and is not connected to the top drive. In this case all the downhole sensors are supplied with power and can send data from downhole to uphole and vice versa.

PDS makes up a galvanic connection while making up the drill pipes. This means an electric pin goes into an electric socket under wet condition (even when the tool joint box is full of mud). This is very different from other WDP technologies. There are two cables protected with a metal tube between the tool joint pin and the tool joint box.

As for tools connectivity, PDS can be completely integrated with existing interfaces and third party systems. Concerning electronics and software, there is no maintenance time.

As regards refurbishing of tool joint connections, it does not differ from conventional drill pipes. PDS components do not limit drill pipe operating time. PDS drill string equipment does not need any special treatment or tools. Handling with a forklift, crane, catwalk, iron roughneck, elevator, set back area is the same as with conventional drill pipes.

4.2.2 PDS power supply

What are the advantages of having power of 300 W along the drill string? Firstly, no need for batteries. They are expensive and critical to handle. Moreover, logistic and environmental concerns are important. Secondly, turbines can be avoided (using a turbine means a limitation to a defined pump range). Thirdly, mud pulsers become unnecessary any more. Finally, batteries run out of power sooner or later. Other systems are limited to the lifetime of the battery which is also dependent on how much data are sent. But PDS gives an unlimited power supply for downhole tools.

300 W is enough to run most downhole sensors. For example, an ASM tool consumes up to 5 W, an MWD tool (inclination, azimuth, tool face, vibration) – 5 – 10 W, activating an RSS – around 150 W for a short time. Today, most sensors are chosen taking into account power consumption. Sometimes their performance is sacrificed in order to prolong battery life. With PDS not much care has to be taken regarding power consumption, as there is unlimited power supply from the surface. High power consumption tools like

³ No papers on PDS were published. All the facts presented here come courtesy of TDE Group via personal communication with Drilling / Mechanical Engineer Medardus Ramsauer in spring of 2019.

imaging tools or neutron magnetic resonance can be powered from surface permanently. This means, for example, that a borehole wall image can be sent from the entire well, which gives important information about the formation.

Another PDS enabled option is downhole charging. Capacitors can be charged with PDS from surface.

With PDS, time between tripping is not influenced by batteries any more. As continuous power supply is from the surface, the time of the drill string in the wellbore is unlimited.

PDS power supply means that the number of tools to be delivered can be reduced. Operation with batteries assumes that one tool is in the hole, the second one is standby, the third one is in the shop for battery service). If there are no batteries, only two tools are enough.

Additionally, cooling of downhole electronics is possible via the surface power supply, allowing to:

- reliably operate tools up to 225°C using conventional 175°C rated electronics.
- use 120°C rated automotive electronics to operate above 150°C to lower cost and expand the choice of available electronics and measurement devices.

To summarize, PDS gives a possibility to develop new generation of high performance downhole tools with simplified design at lower cost.

4.2.3 PDS tests

Extensive component test, simulation of the integrated system, and trials in both dry and muddy environments were successfully carried out. Built-in electronics withstands temperatures up to 175°C. More than 5000 connections were performed using field equipment and video documented. Drill pipe fatigue investigation showed that PDS modifications do not influence on the fatigue performance of the tested drill pipes.

Presently, PDS full scale prototype is going to be installed for integration and functionality tests. Aker BP is a launch partner for this phase. PDS has successfully achieved technology readiness level 6 and technical risk category C. TDE Group is planning to prove PDS technology in 2019: to achieve technology readiness level 7 and technical risk category C or D.

PDS was field-tested with IRIS in Norway. World's first real-time data transfer and continuous power supply without batteries were demonstrated. Rig floor operation procedures proved to be standard.

Time savings resulted from implementation of wired drill pipe telemetry for extended reach drilling

Chapter 5 Time savings resulted from implementation of wired drill pipe telemetry for extended reach drilling

This chapter represents an attempt to assess the impact of wire drill pipe implementation for extended reach drilling in terms of saved time. Two wells are considered – Wis and Man. General information about these wells is provided in Table 5.

	Well Wis	Well Man
Location	Norway	New Zealand
Well type	Appraisal	Appraisal
Well status	P&A	Oil producer
Rig type	Semi-submersible	Jack-up
Rig day rate, \$K	440	515
Conductor	Conductor anchor node	30" stove pipes, 24" conductor (casing drilling)
Deeper casings	26", 17 1/2", 12 1/4", 8 1/2", 6"	20", 17 1/2", 12 1/4", 8 1/2"
Final MD	2354 m	7943 m
Final TVD RKB	713 m	2049 m
Days to reach TD	49	49
Well cost, \$M	109	30

Table 5: General information about wells Wis and Man

PDS technology is supposed to be introduced. According to TDE Group, this does not add any extra time. On the contrary, it saves rig time.

Firstly, PDS provides instantaneous low-latency data transfer with bandwidth 500 kbit/s, which makes data transmission time negligible.

Secondly, PDS data analysis allows for drilling practice optimization. Better understanding of downhole environment should be translated into higher ROP.

Thirdly, WDP has demonstrated a reduction in additional bit and BHA runs through increased component service life and bi-directional communication with downhole tools.

Fourthly, ECD and T&D along-string measurements deliver information about actual wellbore conditions across the well which can be used to optimize hole cleaning time.

Moreover, PDS enables downhole measurements while tripping. Risk of swab/surge effects can be monitored, and trip speed limit may be increased.

A lot of engineering assumptions were made based on personal conversations with competent advisors in May of 2019 and NOV time savings calculator (<https://www.nov.com/isvc/>). The following referencing letters will be used:

- (A) – Antony Martin – Industry Advisor, OMV Drilling Cockpit Superintendent, Lead Directional Drilling Engineer;
- (B) – Yuriy Bedyuk, Baker Hughes directional engineer;
- (C) – NOV time savings calculator.

5.1 Data transmission time

There are several technological operations including data transmission on the critical path:

- downlinking;
- directional surveying;
- shallow pulse testing;
- formation pressure testing.

Time related to these operations can be significantly reduced if WDP is deployed. Additionally, mud pulse decoding issues sometimes occur creating lost time. But PDS is going to provide clean digital signal without any interruptions.

5.1.1 Directional surveys

Downhole surveys are typically taken when drilling stops to make a connection (generally each pipe joint or stand).

The following steps describe the procedure for taking downhole survey. The driller stops rotation. The driller turns the pumps off. The driller locks the drill string, because it must be stationary when taking a survey. The driller increases the flow rate to the programmed level to trigger a survey. Taking a survey usually takes 15–30 s (B).

After taking the survey, the MWD tool transmits a signal to the surface with the survey data encoded in it. The surface computer demodulates the signal and the surface system software processes the survey data. The field engineer determines whether the survey data is within established tolerances. If not, a repeat survey should be taken. Drilling proceeds when the field engineer accepts the survey.

With MPT, waiting on survey usually takes several minutes – from 2 to 6 (A, B). The latency is caused by velocity of the mud pulse travelling. MPT data rate is usually several bps. But PDS is capable of transmitting the signal instantaneously with bandwidth 500 kbit/s, which allows for waiting on survey time elimination. Overall, survey time can be reduced to 1 minute (B, C).

Current average survey time = 6 min (A).

Savings per survey = Average survey time – potential survey time with PDS = 6 min – 1 min = 5 min.

Time savings resulted from implementation of wired drill pipe telemetry for extended reach drilling

Survey time savings are calculated in Table 6.

Well	Surveys per well	Savings per survey, min	Savings per well, h
Wis	60	5	5.0
Man	285	5	23.8

Table 6: Survey time savings

5.1.2 RSS downlinks

Conventional RSS downlinks with MPT are conducted off-bottom. It usually takes several minutes, but WDP makes this time negligible.

Downlink interval – 15 m (A).

Time savings per downlink – 3 min (A).

Downlink time savings are calculated in Table 7.

Well	Length drilled with RSS, m	Downlink interval, m	Downlinks per well	Time savings per downlink, min	Savings per well, h
Wis	1402	15	93	3	4.7
Man	7399	15	493	3	24.7

Table 7: Downlink time savings

5.1.3 Motor toolface orientation

In case of drilling in sliding mode, PDM toolface should be monitored and managed. Toolface orientation is conducted periodically. Then the MWD tool sends the data to the surface. Directional engineers check whether the toolface is correct. If not, the drill string is rotated to a certain angle. PDS, if implemented, eliminates data transmission time.

Toolface orientation interval for Wis well = 20 m (C). According to Man well drilling parameters table, there were 6 toolface orientations.

Time per toolface orientation – 8 min (A).

Toolface orientation time savings are calculated in Table 8.

Well	Length drilled in sliding mode, m	TF orientation interval, m	TF orientations per well	Time savings per TF orientation, min	Savings per well, h
Wis	500	20	25	8	3.3
Man	277	-	6	8	0.8

Table 8: Toolface orientation time savings

5.1.4 Formation pressure tests

Formation pressure testers are utilized to measure formation pressure along a wellbore. The formation pressure data can be utilized directly to choose the casing points and adjust the mud weight and ECD, thus allowing one to increase the drilling efficiency and safely drill into high pressured zones. As with wireline tools, the data also can be used to establish fluid gradients and fluid contacts and to analyze the connectivity between reservoirs.

With MPT, formation pressure test (FPT) data transmission takes about 10 minutes (C), but with PDS – several seconds. FPT time savings are calculated in Table 9.

Well	FPT per well	Savings per FPT, min	Savings per well, h
Wis	16	10	2.7
Man	0	-	-

Table 9: FPT time savings

5.2 Increased ROP

The approach assumes 4 drilling environment features. If an ROP limiter applies, drilling performance for a particular interval can be improved by WDP. Table 10 describes the features and associated ROP increases.

ROP limiter	WDP improvement	ROP increase, %
Shocks, Vibration, Hard Rocks, Stringers	Drilling dynamics real-time data enable drilling parameter optimization	10
Hole Cleaning, ECD Management	Along-string pressure measurements increase ROP limits for hole cleaning	5
Formation Evaluation Logging Density	High data rate doesn't compromise ROP	15
Directional Control, Well Placement	Instantaneous survey data enable higher ROP while maintaining directional control	10

Table 10: ROP limiters (C)

Directional Control and Well Placement is assumed to be an ROP limiter for the considered wells, as they have extended reach and challenging trajectory. Tables 11 and 12 contain information about ROP limiters for wells Wis and Man accordingly.

Time savings resulted from implementation of wired drill pipe telemetry for extended reach drilling

Interval	ROP limiters	ROP increase, %
26''	Directional control	10
17 ½''	ROP was slowed down for hole cleaning purposes, directional control	15
12 ¼''	Hard rocks, directional control	20
8 ½''	Stick-slip, directional control	20
6''	Directional control	10

Table 11: ROP limiters for well Wis

Interval	ROP limiters	ROP increase, %
20''	Directional control	10
17 ½''	Stringers, ROP was maintained for hole cleaning, directional control	25
12 ¼''	Stringers, ROP was cut back for hole cleaning, "the detection was very poor to none because of constant formation changes resulting in downhole noise. The only way to get data points was to let the assembly drill off until enough data was pumped up to allow drilling on", directional control	40
8 ½''	Stick-slip, concretion, directional control	20

Table 12: ROP limiters for well Man

Time savings due to increased ROP are calculated in Tables 13 and 14 for wells Wis and Man accordingly.

Interval	Length, m	Current ROP, m/h	ROP increase, %	Potential ROP, m/h	Time savings, h
26''	57.5	23.0	10	25.3	0.2
17 ½''	162.5	11.1	15	12.7	1.9
12 ¼''	280	9,2	20	11.1	5.1
8 ½''	798	25.0	20	30.0	5.3
6''	604	30.4	10	33.4	1.8
Total					14.3

Table 13: Time savings due to increased ROP for well Wis

Interval	Length, m	Current ROP, m/h	ROP increase, %	Potential ROP, m/h	Time savings, h
20''	277	15.4	10	16.9	1.6
17 ½''	1143	21.2	25	26.5	10.8
12 ¼''	4707	41.8	40	58.5	32.2
8 ½''	1549	19.2	20	23.1	13.4
Total					58.0

Table 14: Time savings due to increased ROP for well Man

5.3 Bit/BHA run reduction

Firstly, WDP enables downhole vibration management. Secondly, WDP provides improved diagnostics capabilities via bi-directional fast communication with downhole tools: status, functionality and sampling rate can be checked and confirmed. Thus, WDP implementation may lead to a reduction in additional bit and BHA runs.

As for Wis well, there were no additional bit/BHA runs. Additional runs for well Man are described in Table 15.

BHA number	Failure reason	Trip time, h
2	MWD failure	11.5
3	Downlinks to the PWD were not working	11
7	MWD failure	81
Total		103.5

Table 15: Additional BHA runs for well Man

NOV time savings calculator assumes that it is possible to save 50% of additional BHA trip time with WDP. Thus, the time saving for well Man is 51.8 h.

5.4 Hole cleaning time

According to NOV calculator, WDP-enabled ASM data help to reduce hole cleaning (circulation) time by 10%. Table 16 shows hole cleaning time savings.

Well	Hole cleaning time, h	Time savings, %	Time savings, h
Wis	222	10	22.2
Man	383	10	38.3

Table 16: Hole cleaning time savings

Time savings resulted from implementation of wired drill pipe telemetry for extended reach drilling

5.5 Time savings summary

Table 17 shows total time savings calculation for wells Wis and Man.

Savings item	Time savings, h - Wis	Time savings, h - Man
Directional surveys	5.0	23.8
RSS downlinks	4.7	24.7
Motor toolface orientation	3.3	0.8
Formation pressure tests	2.7	0
Increased ROP	14.3	58.0
Bit/BHA run reduction	0	51.8
Hole cleaning time	22.2	38.3
Total, h	52.2	197.3
Total, days	2.17	8.22

Table 17: Time savings calculation for wells Wis and Man

Chapter 6 Cost analysis of wired drill pipe telemetry utilization for extended reach drilling

This chapter represents an attempt to assess the impact of wire drill pipe implementation for extended reach drilling in terms of costs. Cost savings related to WDP implementation are compared with the corresponding expenditures.

Two wells are considered – Wis and Man. General information about these wells is provided in Table 5.

6.1 Cost savings

6.1.1 Cost savings resulted from time savings

Cost savings resulted from time savings are calculated in Table 18.

	Wis	Man
Time savings, days	2.17	8.22
Rig day rate	\$440K	\$515K
Cost savings	\$0.957M	\$4.234M

Table 18: Cost savings resulted from time savings

Beside these cost savings, avoidable drilling problems due to the use of real-time data transmission and fast reaction to abnormalities should be also taken into account. For example, the necessity in some sidetracks is caused by bad hole cleaning which can be improved by employing PDS-enabled ASM subs which observe pressure conditions along the string. Operator can save a lot of money by employing WDP where a faster reaction in steering is possible due to dogleg severity reduction and better well placement in the pay zone. But it is very difficult to quantify these indirect long-term benefits.

6.1.2 Downhole tools cost reduction

On the one hand, PDS implementation can lead to higher demand in diverse data-hungry tools with better resolution, which raises associated costs. On another hand, if a service company is willing to adapt completely to PDS and develop new versions of tools without batteries, turbines and mud pulser, these tools will be significantly cheaper.

For this work, we assume that downhole tools will typically get 20% cheaper (according to personal communication with Gerhard Thonhauser on 24.05.2019). Directional drilling, MWD, LWD, and positive displacement motor services daily cost divided by rig day rate is 14% in Eastern Siberia (onshore; courtesy of LLC “Gazprom Bureniye”).

Cost analysis of wired drill pipe telemetry utilization for extended reach drilling

Let us apply a less percentage equal to 8% for wells Wis and Man, as rig day rate depends on the factor of offshore location stronger than downhole tools day rate. PDS downhole tools OPEX reduction is calculated in Table 19.

	Wis	Man
Rig day rate, \$K	440	515
RSS, PDM, MWD, LWD day rate / rig day rate, %	8	8
RSS, PDM, MWD, LWD day rate, \$K	35.2	41.2
Days to reach TD	49	49
RSS, PDM, MWD, LWD cost per well, \$K	1725	2019
RSS, PDM, MWD, LWD cost reduction per well, %	20	20
RSS, PDM, MWD, LWD cost reduction per well, \$K	345	404

Table 19: PDS downhole tools savings

6.2 Additional expenditures

The approach differentiates between PDS-related CAPEX and OPEX, which will be estimated in this section.

6.2.1 CAPEX

The project for OMV will most likely involve direct purchase of the string⁴. Besides this, surface equipment should be preinstalled.

The surface equipment includes a power swivel sub, a tripping sub, a service loop, a control unit. Together, this equipment costs about \$50K⁵. The lifetime is 10 years⁶. Let us assume that 4 wells can be drilled per year. Thus, 40 wells will be drilled during the lifetime.

Surface equipment cost per well = Surface equipment cost / (number of wells drilled per surface equipment lifetime) = \$50K / 40 = \$1K.

Drill string cost per well = PDS drill string cost / (number of wells drilled until the drill string is dumped).

Drill pipes are written-off, if excessive wear or defect was revealed by results of defectoscopy. Let us assume that if hardbanded drill pipes are used then damage of threading is the reason for pipe writing-off.

Number of wells drilled until the pipe is dumped = (number of connections per drill pipe lifetime) / (number of connections per well).

⁴ According to the message from Antony Martin on 16.05.2019

⁵ According to the message from Medardus Ramsauer on 10.05.2019

⁶ According to the message from Medardus Ramsauer on 10.05.2019

If a tool joint withstands 130 connections until it gets refurbished and one tool joint experiences refurbishing 2 times per lifetime, its lifetime is limited by 390 connections.

Approximate number of connections made per Wis well and preliminary number of such wells drilled until the drill pipe is dumped are calculated in Table 20. The similar calculations for HWDP and DC are in Table 21.

	5 7/8" DP	5" DP (19.5)	3 1/2" DP (15.5)
Pipe length, m	12.9	12	12
Max length in hole, m	1570	820	1316
Factor	1.05	1.05	1.05
Length to buy, m	1649	861	1382
Pipes to buy	43	24	38
Connections per pipe	390	390	390
Total connections	16613	9328	14970
Made-up distance, m	5405	820	1316
Connections made	60	9	15
Number of wells drilled until the drill pipe is dumped	92	341	341

Table 20: Preliminary number of wells similar to Wis drilled until the drill pipe is dumped

	5 7/8" HWDP	6 1/2" HWDP	3 1/2" HWDP	8 1/4" DC
Pipe length, m	9.5	9.5	12.9	9
Max pipes in hole, m	23	10	10	11
Factor	1.05	1.05	1.05	1.05
Length to buy, m	229	100	135	104
Pipes to buy	24	11	11	12
Connections per pipe	390	390	390	390
Total connections	9419	4095	4095	4505
Made-up distance, m	1188	190	129	99
Connections made	40	6	4	3
Number of wells drilled until the pipe is dumped	238	647	952	1365

Table 21: Preliminary number of wells similar to Wis drilled until the HWDP/DC is dumped

Cost analysis of wired drill pipe telemetry utilization for extended reach drilling

As for drill string fatigue, let us use comparative drill string design concept (Hill et al., 2004). Figure 16 shows Curvature Index for 5 7/8", 23.40 ppf, G105, Premium Class drill pipe.

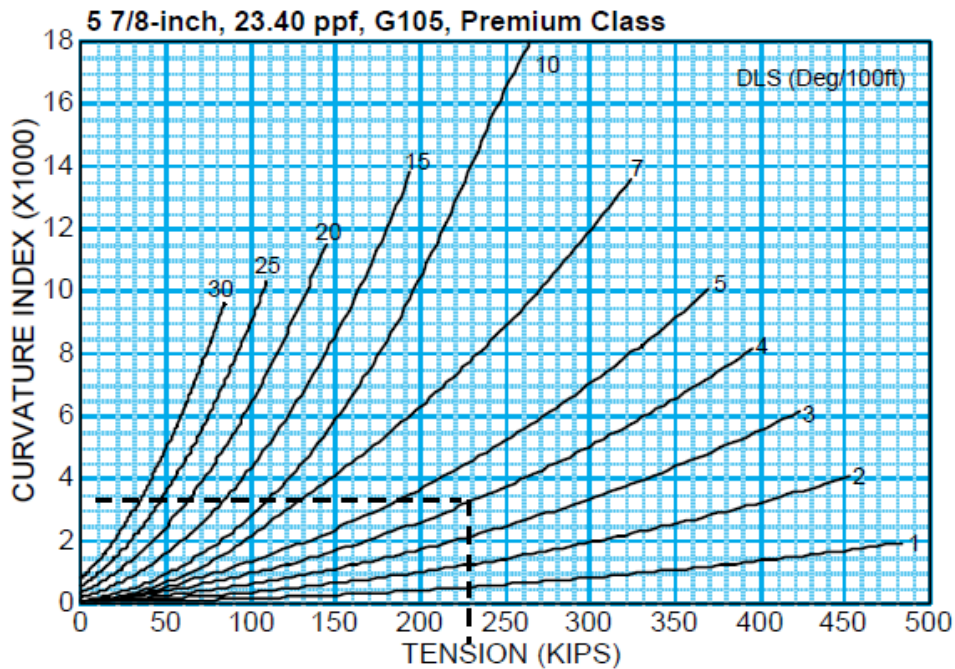

Figure 16: Curvature Index for 5 7/8", 23.40 ppf, G105, Premium Class drill pipe (Hill et al., 2004).

Let us assume that number of wells drilled until the pipe is dumped calculated in Table 20 is estimated for ideal conditions: vertical 3 km long well with DLS = 1 deg/ 30 m. For such well, average tension is about 100 kips. According to Figure 16, CI = 250.

If we consider Wis profile, drill pipes situated in the high-DLS interval (up to 12.5 deg per 30 m) are close to the neutral point (tension is about 7 kips). In this small-tension area, CI is about 250 similar to ideal conditions. Consequently, fatigue is not going to limit the lifetime of drill pipes for this well.

Let us use Stability Index (SI) for HWDP and DC (Figure 17). Assumption: HWDP and DC are dumped after the number of drilled wells calculated in Tables 21 and 23 if SI = 150.

Approximate SI for HWDP and DC and final numbers of drilled wells similar to Wis until the components are dumped can be found in Table 22.

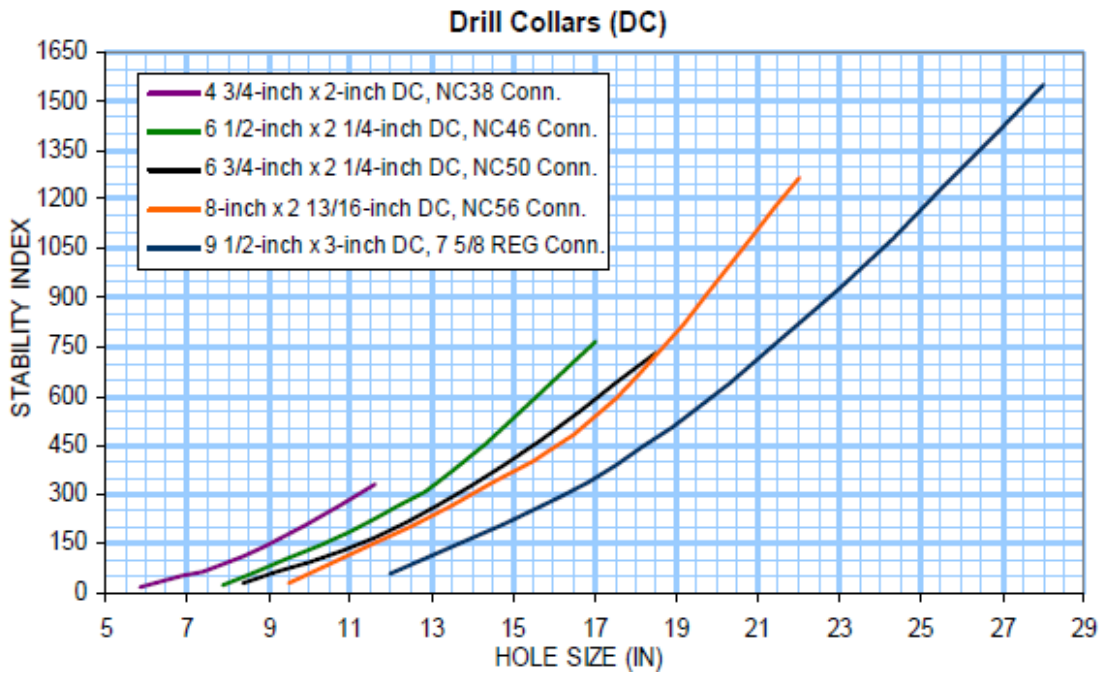

Figure 17: Stability Index for various BHA components (Hill et al., 2004).

	5 7/8" HWDP	6 1/2" HWDP	3 1/2" HWDP	8 1/4" DC
Stability Index ⁷	1047	150	150	1800
Ideal Stability Index	150	150	150	150
SI ratio	1/6.98	1	1	1/12
Preliminary number of wells drilled until the HWDP/DC is dumped	238	647	952	1365
Final number of wells drilled until the HWDP/DC is dumped	34	647	952	114

Table 22: SI and number of wells similar to Wis drilled until the HWDP/DC is dumped

⁷ Drilling and reaming times for each interval were taken into account to calculate SI.

Cost analysis of wired drill pipe telemetry utilization for extended reach drilling

Approximate number of connections made per Man well and preliminary number of such wells drilled until the pipe is dumped are calculated in Table 23.

	5 7/8" DP	5 1/2" HWDP	8 1/4" DC
Pipe length, m	12	9,5	9,5
Max length in hole, m	7812	76	57
Factor	1.05	1.05	1.05
Length to buy, m	8203	80	60
Pipes to buy	684	8	6
Connections per pipe	390	390	390
Total connections	266585	3276	2457
Made-up distance, m	25146	523	399
Connections made	838	17	13
Number of wells drilled until the pipe is dumped	318	188	185

Table 23: Preliminary number of wells similar to Man drilled until the pipe is dumped

To consider drill string fatigue, let us divide number of wells drilled until the drill pipe is dumped calculated in Table 23 by (average CI / ideal CI). Assumption: average CI = maximum CI / 2.

Maximum DLS encountered in Man profile is 5 degrees per 30 m. It is located at 434 m MD. Maximum hook weight while drilling was 224 kips. Subtracting weight of drill pipes in mud above the point (30 kips), we get that maximum tension at 434 m MD is 194 kips. According to Figure 16, for such tension and DLS = 5 deg / (30 m), Curvature Index is equal to 3800. Thus, average CI is 1900. Consequently, it is required to divide number of wells per lifetime by $1900 / 250 = 7.6$. Finally, number of wells drilled until the drill pipe is dumped is $318 / 7.6 = 42$.

As for HWDP and DC, let us apply Stability Index (Figure 17). Approximate SI for HWDP and DC and final numbers of drilled wells similar to Man until the components are dumped can be found in Table 24.

	5 1/2" HWDP	8 1/4" DC
Stability Index ⁸	570	253
Ideal Stability Index	150	150
SI ratio	1/3.80	1/1.68
Preliminary number of wells drilled until the HWDP/DC is dumped	188	185
Final number of wells drilled until the HWDP/DC is dumped	49	110

Table 24: SI and number of wells similar to Man drilled until the HWDP/DC is dumped

The wired drill string costs as two conventional drill strings⁹. Assuming the same lifetime for wired and conventional drill string, we get that additional costs related to the purchase of wired drill string are equal to conventional drill string cost. Costs of drill string components¹⁰ for well Wis are presented in Tables 25 and 26.

	5 7/8" DP (23,4 ppf)	5" DP (19.5 ppf)	3 1/2" DP (15.5 ppf)
Length to buy, m	1649	861	1382
Number of wells drilled until the drill pipe is dumped	92	341	341
Mass per meter, kg/m	34.9	29.1	23.1
Mass to buy, tons	57.6	25.1	31.9
Cost per ton, \$K	2.48	2.70	3.07
Cost, \$K	143	68	98
Cost per well, \$	1547	198	297

Table 25: Costs of drill pipes for well Wis

	5 7/8" HWDP	6 1/2" HWDP	3 1/2" HWDP	8 1/4" DC

⁸ Drilling and reaming times for each interval were taken into account to calculate SI.

⁹ According to the message from Medardus Ramsauer on 08.05.2019

¹⁰ Costs per ton provided in Tables 25, 26, 27 come courtesy of LLC "Gazprom-Bureniye". The pipes are manufactured by TMK-Group.

Cost analysis of wired drill pipe telemetry utilization for extended reach drilling

Length to buy, m	229	100	135	104
Number of wells drilled until the pipe is dumped	34	647	952	114
Mass per meter, kg/m	85	110	39	239
Mass to buy, tons	19.5	11.0	5.3	24.8
Cost per ton, \$K	4.92	4.57	5.65	2.50
Cost, \$K	96	50	30	62
Cost per well, \$	2822	77	31	544

Table 26: Costs of HWDP/DC for well Wis

Costs of drill string components for well Man are presented in Table 27.

	5 7/8" DP	5 1/2" HWDP	8 1/4" DC
Length to buy, m	8203	80	60
Number of wells drilled until the pipe is dumped	42	49	110
Mass per meter, kg/m	35	90	239
Mass to buy, tons	286.3	7.1	14.3
Cost per ton, \$K	4.92	5.05	2.5
Cost, \$K	1407.0	36.1	35.8
Cost per well, \$	33501	737	325

Table 27: Costs of drill string components for well Man

CAPEX related to PDS implementation are summarized in Table 28.

	Wis	Man
Drill string cost, \$K	1092	2958
Surface equipment cost, \$K	50	50
PDS CAPEX, \$K	1142	3058
Additional drill string cost per well, \$K	6	35
Surface equipment cost per well, \$K	1	1
PDS CAPEX per well, \$K	7	36

Table 28: PDS-related CAPEX

6.2.2 OPEX

Additional OPEX related to PDS include daily rate for engineering and data analysis. According to TDE Group (message from Medardus Ramsauer on 08.05.2019), one PDS field engineer is supposed to be on the rig. Let us assume that additional costs for PDS field engineering and data analysis include daily rate \$1K/day and mobilization cost \$2K. Drilling time was 49 days for wells Wis and Man. Thus, PDS OPEX per well are \$51K.

If we consider IntelliServ telemetry, the items mentioned above are also applicable. But in addition to them, booster joints (including batteries for ASM tools) should be taken into account. Operating costs for them are probably equal to \$10K per km drilled. OPEX for IntelliServ booster joints are calculated in Table 29.

	Wis	Man
Final MD, km	2.4	7.9
Booster cost per km drilled, \$K/km	10	10
Booster cost per well, \$K	24	79

Table 29: OPEX for IntelliServ booster joints

Besides the boosters, it is required to take into account downhole tools cost (Table 19) to compare IntelliServ and PDS OPEX (Table 30).

	Wis	Man
Final MD, km	2.4	7.9
IntelliServ booster cost per well, \$K	24	79
RSS, PDM, MWD, LWD cost reduction per well (PDS), \$K	345	404
IntelliServ OPEX – PDS OPEX (per well), \$K	369	483

Table 30: IntelliServ and PDS OPEX comparison

6.3 Cost summary

Cost savings, CAPEX and OPEX related to PDS are summarized in Table 31.

	Wis	Man
Drill string cost, \$K	1092	2958
Surface equipment cost, \$K	50	50
PDS CAPEX, \$K	1142	3058
Additional drill string cost per well, \$K	6	35
Surface equipment cost per well, \$K	1	1
PDS CAPEX per well, \$K	7	36
Field engineering and data analysis costs per well, \$K	51	51
Total PDS costs per well	\$58K	\$87K
Time savings, days	2.17	8.22
Rig day rate	\$440K	\$515K
Cost savings resulted from time savings	\$957K	\$4234K
PDS downhole tools savings per well	\$345K	\$404K
Total PDS cost savings per well	\$1302K	\$4636K
Net savings per well	\$1244K	\$4549K

Table 31: Summary of PDS costs

If PDS business model with drill string rental is deployed, break-even daily rate for PDS services can be calculated (Table 32).

	Wis	Man
Cost savings per well	\$1302K	\$4636K
Drilling time, days	49	49
Break-even PDS daily rate, \$K	27	95

Table 32: Break-even PDS daily rate

According to Table 31, CAPEX will be paid back after just one well. Overall, the cost analysis shows attractiveness of PDS technology in comparison with both mud-pulse telemetry and IntelliServ.

Chapter 7 Conclusion

The idea of transmitting electric signals along the drill string has been developing for more than 80 years (Karcher, 1932). More than 250 wells have been drilled using the Intelliserv WDP telemetry (Foster and Macmillan, 2018). But reliability concerns and high costs did not let this technology to make a market breakthrough. Currently, several companies are trying to create improved WDP systems using different physical principles of operation.

Powerline Drillstring technology was selected as a candidate for extended reach drilling. Two offshore wells – Wis and Man – are under consideration in the thesis.

The main benefit of WDP technology is high-bandwidth low-latency data transmission. It allows for better understanding of downhole conditions, drilling process optimization, and, consequently, drilling time reduction. According to the time estimation, the highest time savings are expected in the areas of directional surveying, downlinking, hole cleaning, BHA/bit run reduction and ROP increase. Overall, about 1 day per km drilled can be saved. Considering offshore rig day rates, we derive that \$1M per 2 km drilled is the benefit enabled by WDP.

The second WDP advantage, specific for Powerline Drillstring, lies in the area of power supply. With this possibility, batteries, turbines, and mud pulsers can be avoided in downhole tools, which makes them significantly cheaper – by \$0.3M for Wis and by \$0.4M for Man. Unlike IntelliServ, PDS does not include any boosters which may cost several tens of \$K per well.

Wired drill string was calculated as doubled conventional drill string cost. Taking into account number of pipe connections made and loading conditions in the wells (Hill et al., 2004), it is possible to estimate approximate lifetime for each component, and, subsequently, wired drill string cost per well. After adding surface equipment cost and PDS engineering costs, it became evident that total costs are incomparably less than PDS cost savings.

Net cost savings are \$1.2M (well Wis) and \$4.5M (well Man). CAPEX will be paid back after just one well. Overall, the cost analysis shows superiority of PDS in comparison with both mud-pulse telemetry and IntelliServ. The most important factors which make PDS attractive for this cases are as follows:

- high time savings potential due to the challenging trajectories, hole cleaning problems, intensive downlinking and surveying;
- tremendous rig day rates;
- high downhole tools day rates;
- reasonable wired drill string cost;
- low PDS field engineering and data analysis daily rate.

We can conclude that Powerline Drillstring is worth implementing for offshore ERD. During the next, more detailed, feasibility study the main engineering assumptions used here should be double-checked. All potentially involved parties – an operating company, a WDP provider, a drilling contractor, service companies – should participate

Conclusion

in the discussion. A business model should be selected. The workflows are going to be changed: the operator should plan WDP deployment, service companies should redesign their tools, the WDP company should be ready to supply required number of pipes and maintain them.

What is important, wired drill pipe technology should not be considered as the universal solution. Preliminary feasibility study conducted by an expert group is always mandatory for a future successful WDP deployment.

Bibliography

Ali, T. H., Sas, M., Hood, J. A., Lemke, S. R., Srinivasan, A., McKay, J., ... Reeves, M. (2008, January 1). "High Speed Telemetry Drill Pipe Network Optimizes Drilling Dynamics And Wellbore Placement." Society of Petroleum Engineers. doi:10.2118/112636-MS

Bratton, T.R., Rezmer-Cooper, I.M., Desroches, J., Gille Y-E., Li, Q., McFayden, M. "How to Diagnose Drilling Induced Fractures in Wells Drilled with Oil-Based Muds with Real-Time Resistivity and Pressure Measurements", paper SPE/IADC 67742, presented at the SPE/IADC Drilling Conference, Amsterdam, The Netherlands, 27 February – 1 March, 2001.

Chandler, R. B., Muradov, A., Payne, M. L., Wright, J. C., Jellison, M. J., Reeves, M. E., & Pixton, D. (2005, January 1). "Beyond Stress Relief Features...The Bottom Hole Assembly Connection for the Harshest Fatigue Environments." Society of Petroleum Engineers. doi:10.2118/97430-MS

Coley, C.J. and Edwards, S.T. 2013. "The Use of Along String Annular Pressure Measurements to Monitor Solids Transport and Hole Cleaning." Paper SPE/IADC 163567 Presented at the SPE/IADC Drilling Conference, Amsterdam, Netherlands, February.

Craig, A. D., & Adsit, R. (2014, October 27). "Drillstring Network 2.0: An Enhanced Drillstring Network Based on 100 Wells of Experience." Society of Petroleum Engineers. doi:10.2118/170692-MS

Craig, A. D., Jackson, T. A., Ramnarace, D., Schultze, R., & Briscoe, M. (2013, March 5). "The Evolution of Wired Drilling Tools: A Background, History and Learnings from the Development of a Suite of Drilling Tools for Wired Drillstrings." Society of Petroleum Engineers. doi:10.2118/163416-MS

Edwards, S. T., Coley, C. J., Whitley, N. A., Keck, R. G., Ramnath, V., Foster, T., ... Honey, M. (2013, March 5). "A Summary Of Wired Drill Pipe (IntelliServ Networked Drillstring) Field Trials And Deployment In BP." Society of Petroleum Engineers. doi:10.2118/163560-MS

Edwards, S.T., Bratton, T.R., Standifird, W.B., "Accidental Geomechanics" paper SPE 78205, presented at the SPE/ISRM Rock Mechanics Conference, Irving, TX, 20-23 October 2002.

Fay, J. B., Fay, H., & Couturier, A. (1992, January 1). "Wired Pipes for a High-Data-Rate MWD System." Society of Petroleum Engineers. doi:10.2118/24971-MS

Foster, R., & Macmillan, R. (2018, April 30). "High Speed Telemetry on Wired Drill Pipe, History, and Impact on Drilling Process." Offshore Technology Conference. doi:10.4043/28735-MS

Fredericks, P. D., Reitsma, D., Runggai, T., Hudson, J. N., Zaeper, R., Backhaus, O., & Hernandez, M. (2008, January 1). "Successful Implementation of First Closed Loop,

Bibliography

Multiservice Control System for Automated Pressure Management in a Shallow Gas Well Offshore Myanmar." Society of Petroleum Engineers. doi:10.2118/112651-MS

Giltner, M., Earle, L., Willis, J., Tellez, D., & Neel, R. (2019, March 4). "Performance Impact of Downhole Data from Wired Drill Pipe and Downhole Sensors." Society of Petroleum Engineers. doi:10.2118/194093-MS

Gravdal, A. E., Lorentzen, R. J., & Time, R. W. (2010, January 1). "Wired Drill Pipe Telemetry Enables Real-Time Evaluation of Kick During Managed Pressure Drilling." Society of Petroleum Engineers. doi:10.2118/132989-MS

Gravley, W. (1983, August 1). "Review of Downhole Measurement-While-Drilling Systems." Society of Petroleum Engineers. doi:10.2118/10036-PA

Grymalyuk, S., Schimanski, M., & Lilledal, L. (2016, November 7). "Innovative Expandable Under Reamer Technology in Combination with Wired Drill Pipe Technology." Society of Petroleum Engineers. doi:10.2118/183518-MS

Hatch, A. J., Shepherd, N., Diepeveen, P., & Affleck, G. (2011, January 1). "Managing New Technology Introduction to Provide Maximum Benefit." Society of Petroleum Engineers. doi:10.2118/140391-MS

Hawthorn, A., & Aguilar, S. (2017, October 9). "New Wireless Acoustic Telemetry System Allows Real-Time Downhole Data Transmission through Regular Drillpipe." Society of Petroleum Engineers. doi:10.2118/187082-MS

Hernandez, M., MacNeill, D. W., Reeves, M., Kirkwood, A. D., Ruzska, J. P., Zaeper, R., & Lemke, S. R. (2008, January 1). "High-Speed Wired Drillstring Telemetry Network Delivers Increased Safety, Efficiency, Reliability, and Productivity to the Drilling Industry." Society of Petroleum Engineers. doi:10.2118/113157-MS

Hill, T., Ellis, S., Lee, K., Reynolds, N., & Zheng, N. (2004, January 1). An Innovative Design Approach To Reduce Drill String Fatigue. Society of Petroleum Engineers. doi:10.2118/87188-MS

Hovda, S., Wolter, H., Kaasa, G.-O., & Olberg, T. S. (2008, January 1). "Potential of Ultra High-Speed Drill String Telemetry in Future Improvements of the Drilling Process Control." Society of Petroleum Engineers. doi:10.2118/115196-MS

Israel, R., McCrae, D., Sperry, N., Gorham, B., Thompson, J., Raese, K., ... Coit, A. (2018, September 24). "Delivering Drilling Automation II – Novel Automation Platform and Wired Drill Pipe Deployed on Arctic Drilling Operations." Society of Petroleum Engineers. doi:10.2118/191574-MS

Jellison, M. J., Hall, D. R., Howard, D. C., Hall, H. T., Long, R. C., Chandler, R. B., & Pixton, D. S. (2003, January 1). "Telemetry Drill Pipe: Enabling Technology for the Downhole Internet." Society of Petroleum Engineers. doi:10.2118/79885-MS

Karcher, J.C., "Method and Apparatus for Exploring Bore Holes", U.S. Patent 1 927 664, 1932.

Klotz, C., Kaniappan, A., Thorsen, A. K., Nathan, E., Jahangir, M., & Lie, L. (2008, January 1). "A New Mud Pulse Telemetry System Reduces Risks When Drilling Complex Extended Reach Wells." Society of Petroleum Engineers. doi:10.2118/115203-MS

- Lawrence, L., Redmond, B., Russell, R. B., MacNeill, D., Reeves, M. E., & Hernandez, M. (2009, January 1). "Intelligent Wired Drill-Pipe System Provides Significant Improvements in Drilling Performance on Offshore Australia Development." Offshore Technology Conference. doi:10.4043/20067-MS
- Lesso, W. G., Laastad, H., Newton, A., & Olberg, T. S. (2008, January 1). "The Utilization of the Massive Amount of Real Time Data Acquired in Wired-Drillpipe Operations." Society of Petroleum Engineers. doi:10.2118/112702-MS
- Lurie, P., Head, P., & Smith, J. E. (2003, January 1). "Smart Drilling with ELECTRIC DRILLSTRING." Society of Petroleum Engineers. doi:10.2118/79886-MS
- Macpherson, J., Roders, I., Schoenborn, K., Mieting, R., & Lopez, F. (2019, March 4). "Smart Wired Pipe: Drilling Field Trials. Society of Petroleum Engineers." doi:10.2118/194095-MS
- Manning, M. J., Macpherson, J. D., Taylor, D. E., Baksh, N., Peveto, C., Farnsworth, L., & Lemke, S. R. (2008, January 1). "Wired Pipe-Enabled Logging While Drilling Applications." International Petroleum Technology Conference. doi:10.2523/IPTC-12504-MS
- McCartney, C., Allen, S., Hernandez, M., MacFarlane, D., Baksh, A., & Reeves, M. E. (2009, January 1). "Step-Change Improvements With Wired-Pipe Telemetry." Society of Petroleum Engineers. doi:10.2118/119570-MS
- McCubrey, R., Johnson, A., Adsit, R., Veeningen, D., & Pixton, D. (2013, March 5). "System Reliability and Metrics for the High-Speed Networked Drillstring Telemetry and Along String Evaluation." Society of Petroleum Engineers. doi:10.2118/163570-MS
- Nygard, V., Jahangir, M., Gravem, T., Nathan, E., Evans, J. G., Reeves, M., ... Hovda, S. (2008, January 1). "A Step Change in Total System Approach Through Wired Drillpipe Technology." Society of Petroleum Engineers. doi:10.2118/112742-MS
- Pixton, D. S., Asgharzadeh Shishavan, R., Perez, H. D., Hedengren, J. D., & Craig, A. (2014, April 8). "Addressing UBO and MPD Challenges with Wired Drill Pipe Telemetry." Society of Petroleum Engineers. doi:10.2118/168953-MS
- Rasmus, J., Dorel, A., Azizi, T., David, A., Duran, E., Lopez, H., ... Ochoa, E. (2013, March 5). "Utilizing Wired Drill Pipe Technology During Managed Pressure Drilling Operations to Maintain Direction Control, Constant Bottom-hole Pressures, and Well-bore Integrity in a Deep, Ultra-depleted Reservoir." Society of Petroleum Engineers. doi:10.2118/163501-MS
- Reeves, M. E., Camwell, P. L., & McRory, J. (2011, January 1). "High Speed Acoustic Telemetry Network Enables Real-Time Along String Measurements, Greatly Reducing Drilling Risk." Society of Petroleum Engineers. doi:10.2118/145566-MS
- Reeves, M. E., Payne, M. L., Ismayilov, A. G., & Jellison, M. J. (2005, January 1). "Intelligent Drill String Field Trials Demonstrate Technology Functionality." Society of Petroleum Engineers. doi:10.2118/92477-MS
- Reeves, M., MacPherson, J. D., Zaeper, R., Bert, D. R., Shursen, J., Armagost, W. K., ... Hernandez, M. (2006, January 1). "High Speed Drill String Telemetry Network Enables

Bibliography

New Real Time Drilling and Measurement Technologies." Society of Petroleum Engineers. doi:10.2118/99134-MS

Russell, R. B., Hernandez, M., MacNeill, D. W., Reeves, M. E., & Hamel, P. (2008, January 1). "Intelligent"; "Wired Drill-Pipe System Allows Operators to Take Full Advantage of Latest Downhole Sensor Developments." International Petroleum Technology Conference. doi:10.2523/IPTC-12449-MS

Schils, S., Teelken, R., van Burkleo, B., Rossa, O. J., & Edwards, N. (2016, March 1). "The Use of Wired Drillpipe Technology in a Complex Drilling Environment Increased Drilling Efficiency and Reduced Well Times." Society of Petroleum Engineers. doi:10.2118/178863-MS

Schnitger, J., & Macpherson, J. D. (2009, January 1). "Signal Attenuation for Electromagnetic Telemetry Systems." Society of Petroleum Engineers. doi:10.2118/118872-MS

Sehsah, O., Ghazzawi, A., Vie, G. J., Al-Tajar, T., Ali, A., Al-Mohammed, A. H., ... Balka, M. (2017, November 13). "Intelligent Drilling System: Expanding the Envelope of Wired Drill Pipe." Society of Petroleum Engineers. doi:10.2118/188321-MS

Teelken, R., Jaring, C., Craig, A., Allan, R., Roberts, H., Hatch, A., & Shepherd, N. (2016, March 1). "Implementation of Wired Drill Pipe Saved Multiple Days Per Well, by Addressing Performance Limiters, Increasing Drilling Efficiency." Society of Petroleum Engineers. doi:10.2118/178798-MS

Veeningen, D. M. (2011, January 1). "Novel High Speed Telemetry System With Measurements Along the String Mitigates Drilling Risk and Improves Drilling Efficiency." Society of Petroleum Engineers. doi:10.2118/143430-MS

Veeningen, D. M. (2012, January 1). "Identify Safe Drilling Margin, Detect Kicks, Analyze Negative Pressure Tests and Better Well Control Independently from Surface Measurements, Addressing Recommendations for Deepwater." Society of Petroleum Engineers. doi:10.2118/157220-MS

Veeningen, D. M., Fear, M. J., & Willson, S. M. (2012, January 1). "Transformational Reduction in Non-productive Time through Implementation of Broadband Networked Drill-string and Modified Drilling Practices in an Extended Reach Drilling Campaign." Society of Petroleum Engineers. doi:10.2118/156364-MS

Veeningen, D. M., Palmer, J., Steinicke, G., Saenz, J., & Hansen, T. (2012, January 1). "From Field Test to Successful Integration of Broadband Drillstring System for Offshore Extended Reach Wells." Society of Petroleum Engineers. doi:10.2118/151386-MS

Ward, C., Clark, R. "Anatomy of a Ballooning Borehole Using PWD", Overpressures in Petroleum Exploration; Proc Workshop, Pau, April 1998.

Wolfe, C. A., Morris, S. A., & Baule, A. (2009, January 1). "Enhanced Real-Time Wellbore Stability Monitoring Using High Definition Imaging With Wired-Pipe Telemetry." Society of Petroleum Engineers. doi:10.2118/119808-MS

Wolter, H., Gjerding, K., Reeves, M. E., Hernandez, M., Macpherson, J. D., Heisig, G., & Zaeper, R. (2007, January 1). "The First Offshore Use of an Ultra High Speed Drillstring

Bibliography

Telemetry Network Involving a Full LWD Logging Suite and Rotary Steerable Drilling System." Society of Petroleum Engineers. doi:10.2118/110939-MS

Zalluhoglu, U., Demirer, N., Marck, J., Gharib, H., & Darbe, R. (2019, March 4). „Steering Advisory System for Rotary Steerable Systems." Society of Petroleum Engineers. doi:10.2118/194090-MS

Zalluhoglu, U., Gharib, H., Marck, J., Demirer, N., & Darbe, R. (2019, March 4). "Steering Advisory System for Mud Motors." Society of Petroleum Engineers. doi:10.2118/194077-MS

Acronyms

<i>ASM</i>	Along-String Measurement
<i>BHA</i>	Bottom-Hole Assembly
<i>CAPEX</i>	Capital Expenditures
<i>CI</i>	Curvature Index
<i>DC</i>	Drill Collar
<i>DD</i>	Directional Drilling
<i>DLS</i>	Dogleg Severity
<i>ECD</i>	Equivalent Circulating Density
<i>EMR</i>	Electromagnetic Resonance
<i>ERD</i>	Extended Reach Drilling
<i>ID</i>	Inner Diameter
<i>LCM</i>	Lost Circulation Material
<i>LWD</i>	Logging While Drilling
<i>MPD</i>	Managed Pressure Drilling
<i>MPT</i>	Mud Pulse Telemetry
<i>MTBF</i>	Mean Time Between Failure
<i>MWD</i>	Measurements While Drilling
<i>HWDP</i>	Heavy Weight Drill Pipe
<i>NPT</i>	Non-Productive Time
<i>OD</i>	Outer Diameter
<i>OPEX</i>	Operational Expenditures
<i>PDM</i>	Positive Displacement Motor
<i>PDS</i>	Powerline Drillstring
<i>POOH</i>	Pull-Out-Of-Hole
<i>RIH</i>	Run-In-Hole
<i>RMUT</i>	Recommended Make-Up Torque
<i>ROP</i>	Rate Of Penetration
<i>RPM</i>	Rotations Per Minute
<i>RSS</i>	Rotary Steerable System
<i>SI</i>	Stability Index

Acronyms

<i>SWD</i>	Seismic While Drilling
<i>T&D</i>	Torque and Drag
<i>WOB</i>	Weight-On-Bit

List of Figures

Figure 1: Components in a joint of drill pipe of a micro-repeater based wired pipe system (Macpherson et al., 2019).....	7
Figure 2: Wired Drill Pipe system components (Schils et al., 2016).	17
Figure 3: The non-contact line coupler uses induction to transmit data from one connection to another. (Jellison et al., 2003).....	18
Figure 4: WDP version 1 coil mounted in the centre of the shoulder of the pin face (Sehsah et al., 2017).....	18
Figure 5: Cutaway view of the telemetry drill pipe system in a drill pipe connection. The inductive coil fits in a shallow groove inside the secondary torque shoulder of the tool joint (Reeves et al., 2005).....	19
Figure 6: A top drive sub provides a communication link between the rotating drill string and a data acquisition system (Jellison et al., 2003).	21
Figure 7: Graph of network drillstring uptime, average NPT, and MTBF over commercial deployments in the period 2008-2011 (McCubrey et al., 2013).....	24
Figure 8: Location of wells drilled using IntelliServ Version 1 (offshore – blue, land – brown) (Craig and Adsit, 2014).	26
Figure 9: Third generation double-shouldered connection (Craig and Adsit, 2014).	28
Figure 10: Basic configuration of WDP (Craig and Adsit, 2014).....	28
Figure 11: Modifications of inductive connector position and actuation (Craig and Adsit, 2014).	29
Figure 12: On the left – WDP Version 1 coil. On the right – WDP Version 2 (Sehsah et al., 2017).	29
Figure 13: WDP Version 1 vs Version 2 coil placement (Sehsah et al., 2017).....	30
Figure 14: Second generation coil is much more durable (Craig and Adsit, 2014).	30
Figure 15: WDP version 2 designed to be field removable and replaceable (Sehsah et al., 2017).31	
Figure 16: Curvature Index for 5 7/8", 23.40 ppf, G105, Premium Class drill pipe (Hill et al., 2004).....	52
Figure 17: Stability Index for various BHA components (Hill et al., 2004).	53

List of Tables

Table 1: Comparison of IntelliServ and PDS	16
Table 2: Summary of Well Campaigns IntelliServ Version 1 WDP (as of November 2013) (Craig and Adsit, 2014)	25
Table 3: Modifications implemented with IntelliServ Version 2	27
Table 4: Overview of ‘net’ time savings per well and for the project (Schils et al., 2016)	36
Table 5: General information about wells Wis and Man	42
Table 6: Survey time savings	44
Table 7: Downlink time savings	44
Table 8: Toolface orientation time savings	44
Table 9: FPT time savings	45
Table 10: ROP limiters (C).....	45
Table 11: ROP limiters for well Wis.....	46
Table 12: ROP limiters for well Man	46
Table 13: Time savings due to increased ROP for well Wis	46
Table 14: Time savings due to increased ROP for well Man.....	47
Table 15: Additional BHA runs for well Man	47
Table 16: Hole cleaning time savings	47
Table 17: Time savings calculation for wells Wis and Man	48
Table 18: Cost savings resulted from time savings	49
Table 19: PDS downhole tools savings.....	50
Table 20: Preliminary number of wells similar to Wis drilled until the drill pipe is dumped	51
Table 21: Preliminary number of wells similar to Wis drilled until the HWDP/DC is dumped .	51
Table 22: SI and number of wells similar to Wis drilled until the HWDP/DC is dumped	53
Table 23: Preliminary number of wells similar to Man drilled until the pipe is dumped	54
Table 24: SI and number of wells similar to Man drilled until the HWDP/DC is dumped.....	55
Table 25: Costs of drill pipes for well Wis	55
Table 26: Costs of HWDP/DC for well Wis	56
Table 27: Costs of drill string components for well Man.....	56
Table 28: PDS-related CAPEX	57
Table 29: OPEX for IntelliServ booster joints	57
Table 30: IntelliServ and PDS OPEX comparison	57
Table 31: Summary of PDS costs.....	58
Table 32: Break-even PDS daily rate.....	58