

Master Thesis

Pressure Testing of Inner Liner Assemblies in Internal-External Upset Drillpipes



Supervised by: Univ.-Prof. Dipl.-Ing. Dr.mont. Gerhard Thonhauser
Chair of Drilling and Completion Engineering, Mining University of Leoben

Project Coordination: Dipl.-Ing. Anton Scheibelmasser
ADS – Advanced Drilling Solutions GmbH

Approval date: 10 September 2012

This thesis was handed in at the Chair for Drilling and Completion Engineering within the Department of Mineral Resources and Petroleum Engineering at the Mining University of Leoben.

The thesis project was accomplished in cooperation with ADS – Advanced Drilling Solutions GmbH in Leoben.



This Master Thesis has not been submitted elsewhere for examination purpose.

Eidesstattliche Erklärung

Ich erkläre an Eides statt, dass ich diese Arbeit selbständig verfasst, andere als die angegebenen Quellen und Hilfsmittel nicht benutzt und mich auch sonst keiner unerlaubten Hilfsmittel bedient habe.

Affidavit

I declare in lieu of oath, that I wrote this thesis and performed the associated research myself, using only literature cited in this volume.

Peter Steindler

Leoben, in September 2012

Acknowledgement

First of all I want to thank Professor Gerhard Thonhauser for providing me the opportunity to work within ADS company and to write my thesis about such an interesting and challenging R&D project.

I also want to thank DI Anton Scheibelmasser for his great affords and his support within my time at ADS. The project would not have been possible to realize without the enormous support of Johann Jud who not only greatly influenced the design work but also spent many hours on supporting the whole project with his immense experience in mechanical engineering. I also want to thank Alexander Fine, MSc for many wise inputs throughout the whole project. Manfred Gutschelhofer spent a lot of time on revisioning the drawings and being in contact with the manufacturing companies. Also great thanks to Michael Korak who spent plenty of days on the lathe and in the workshop to manufacture parts and components for the test beds with impressive precision and care. I also want to express my thanks to Joachim Roth who constructed the wooden bench and the cover for the test bed.

Also I want to thank all ADS/TDE employees for the friendly and helpful working atmosphere at the workshop in Prettachstraße.

Above all I would like to thank my parents. Without their great support throughout the last years my studies would not have been possible.

Table of Contents

Abstract	7
Kurzfassung	8
Introduction	9
Inner Liner Tube Assemblies in Drillpipes	10
General Aspects – The Basic Liner Assembly Design	10
The Liner Tube.....	13
Deformation Calculation.....	13
Pressure Loss Calculation	15
The Liner Sealing	26
The Annular Filling Material	28
Required Properties of the Filler Material.....	28
Method of Filling	29
Pros and Cons	30
Applications	31
Inner Pressure Test Bed	32
General Aspects.....	32
Sealing-Only Tester	33
Requirements and Features	33
Basic Idea and Function.....	33
Mechanical Design and Layout.....	34
Manufacturing and Construction.....	43
Liner & Sealing Tester.....	44
Requirements and Features	44
Basic Idea and Function.....	44
Mechanical Design and Layout.....	48
Manufacturing and Construction.....	52
Protective Bushing Tester 1.....	53
Requirements and Features	53
Basic Idea and Function.....	53
Mechanical Design and Layout.....	55
Manufacturing and Construction.....	56
Protective Bushing Tester 2.....	58
Requirement and Features	58
Basic Idea and Function.....	58
Mechanical Design and Layout.....	59
Manufacturing and Construction.....	60
Hoisting and Safety Equipment	61
Bench with Cover	61
Hoisting Equipment.....	62
Pressure Testing in the Shop	66
Safety Rules for Inner Pressure Test Beds.....	66
Pressure Testing the Liner Assembly	67
Sealing-Only Tester	67
Testing Arrangement and Procedure	67
Testing Results.....	70
Conclusion.....	71
Liner&Sealing Tester	72
Testing Arrangement and Procedure	72
Protective Bushing Tester 1.....	75
Testing Arrangement and Procedure	75
Testing Results.....	76
Conclusion.....	77
Protective Bushing Tester 2.....	78
Testing Arrangement and Procedure	78
Testing Results.....	80

Conclusion.....	82
Conclusion.....	83
Abbreviations	84
References	85
Appendix A – Pressure Loss Calculation	87
Appendix B – Blueprints	91
Appendix C – Part- and Material Lists	101
Appendix D – Budget Plan.....	106

List of Figures

Figure 1: Box-End (upper drawing) and Pin-End of the proposed Inner Liner Assembly [2]	10
Figure 2: Stresses in Pipe Wall [4].....	13
Figure 3: Pressure Profile Production Section – standard DP	18
Figure 4: Pressure Profile Production Section – modified DP	19
Figure 5: Pressure Profile 5000m Well – standard DP	21
Figure 6: Pressure Profile 5000m Well – modified DP	22
Figure 7: Pressure Loss Comparison in dependence of the Flow Rate	23
Figure 8: FEA for Seal Group Liner Nut x Pin with Metal Seal Rings [6].....	26
Figure 9: The Components of the Sealing Assembly – Nut, Inner and External Ring, Pin	27
Figure 10: FEA for Seal Group Protective Bushing x DP [7].....	27
Figure 11: FEA for Seal Group Protective Bushing x Liner Nut [8].....	28
Figure 12: Ceramic Beads as Filler Material [10].....	29
Figure 13: Arrangement for Filling Tests	30
Figure 14: Sealing- Only Test Bed.....	33
Figure 15: Deformation Calculation of a Circular Plate under Single Force [15].....	36
Figure 16: Disk Spring Equation [16].....	36
Figure 17: Groove Design for Axial Cover under Inner Pressure [26]	42
Figure 18: Manufactured Components for the Test Bed (200)	43
Figure 19: Main Inner Pressure Test Bed	44
Figure 20: Main Pipe with Flanges.....	45
Figure 21: Sketch of Welding Seam	50
Figure 22: Manufactured Components for the Test Bed (100)	52
Figure 23: Protective Bushing Tester 1	53
Figure 24: Manufactured Components of the Test Bed (300).....	57
Figure 25: Protective Bushing Tester 2	58
Figure 26: Groove Design for Piston Packing [26].....	60
Figure 27: Manufactured Components of the Test Bed (400).....	60

Figure 28: Wooden Table with Cover	61
Figure 29: The Hoisting Equipment	62
Figure 30: Cross-section of horizontal beam [32]	63
Figure 31: Using the Bench and the Hoisting Equipment (right for oil discharge).....	65
Figure 32: Cone Wrench to hold Modified Nut while tightening Pin.....	67
Figure 33: Optional Socket Wrench for Pump Connection	67
Figure 34: Switch for tightening Pin	68
Figure 35: Elongation Lever for Torque Wrench.....	68
Figure 36: Main Pipe in Fixation Prism	69
Figure 37: Testbed in Fixation Prism with Axial Fixation ready to apply Torque.....	69
Figure 38: Filling of the Test Cell in upright Position	70
Figure 39: Test Bed ready to apply Pressure.....	70
Figure 40: Time vs Pressure Chart.....	71
Figure 41: Main Pipe after Testing.....	71
Figure 42: Tools for Liner&Sealing Test Bed	72
Figure 43: Funnels for Filling the Liner&Sealing Test Bed	73
Figure 44: Exterior and Interior of the Test Bed	75
Figure 45: Filling of the Test Bed	76
Figure 46: Using a Dial Extensometer for adjusting the Axial Tightness	76
Figure 47: Test Setup for the Extensometer	77
Figure 48: Tool for Protective Bushing Test Bed 2	78
Figure 49: Protective Bushing screwed in Liner Nut (hand tight) with Ring of Mounting Tool.....	79
Figure 50: Protective Bushing in Fixation Prism to apply Torque	79
Figure 51: Middle Plate with Protective Bushing in Fixation Prism	79
Figure 52: Mounting O-rings and End Plates	80
Figure 53: Preparing for Testing	80
Figure 54: Time vs Pressure Chart.....	81
Figure 55: Oil-free Inner Components after Testing	81
Figure 56: Circumferential Contact of Protective Bushing in Liner Nut.....	82

Abstract

When mounting a thin-walled tubular in an internal upset drillpipe and fixing it in the tool joints, it is possible to create an annular volume between the drillpipe wall and the inner liner tube. This created space can serve for various duties like placing measuring equipment like strain gauges for example, electronics and sensors as well as insulation material or telemetry and power supply lines. For the success of these applications it is absolutely necessary that the annular volume is sealed against the drilling mud that is pumped down inside the drillstring. The target of this thesis project is to determine and investigate the tightness and integrity of the inner liner sealing assemblies within 5in, 19.5lb/ft, G105 internal-external upset drillpipes. Therefore various inner pressure testing facilities were designed and constructed in order to be able to pressurize the sealing components of the liner assembly.

The main test bed is in fact a model of a drillpipe excluding the connectors and shorter in length, but having the same inner shape and diameters. Having a liner tube installed and using the proposed sealing assemblies it is possible to mount the desired equipment in the annular volume (filler material, data lines...). By pressurizing the test cell to 700bar using a hydraulic pump, leakages of the metal sealing or a failure of the liner tube itself can be detected by observing a pressure drop.

Kurzfassung

Mit dem Einbau eines dünnwandigen Rohres in ein innen gestauchtes Bohrgestänge, sowie mit dem Abdichten dieses Innenrohres in den Enden der Bohrstange ist es möglich einen Ringraum zu erzeugen. Dieser Raum zwischen Bohrstangenwand und Innenrohr kann für die verschiedensten Anwendungen genutzt werden, wie zum Beispiel dem Einbau von Messsensoren wie Dehnmessstreifen oder Elektronikkomponenten, sowie dem Einbringen von Dämmstoffen zur Isolierung oder dem Verlegen von Daten- und Stromleitungen. Für die Funktion dieser Anwendungen ist es absolut wichtig, dass dieser Ringraum gegen den Innendruck des Bohrschlammes, welcher durch den Bohrstrang gepumpt wird, abgedichtet ist. Das Ziel dieses Projektes ist es nun die Funktion der Dichtkomponenten in dem Innenrohrdesign zu überprüfen. Dazu wurden für die einzelnen Dichtelemente Innendruckteststände entworfen, ausgelegt und konstruiert.

Der Haupt-Teststand ist praktisch ein Model einer gekürzten Bohrstange mit den gleichen Innenabmessungen wie im Original aber ohne den Gewindemuffen und -nippeln. Nach dem Einbau des Innenrohres sowie dessen Abdichtung kann auch Füllmaterial oder Verkabelung in den Ringraum eingebracht werden. Mittels einer Hydraulikpumpe ist es nun möglich den Teststand mit 700bar Innendruck zu belasten. Wird dabei ein Druckverlust wahrgenommen ist dies ein Zeichen für eine Leckage der Metaldichtung oder gar eines Versagens des Innenrohres.

Introduction

Problem Description

When thinking on extend reach or shale gas drilling like in the U.S. or ultra deep water exploration done in the Santos Basin for example, it is obvious that today drilling projects get more and more challenging and by that steadily increasing cost are involved. Rig rates for semisubmersibles up to one million U.S. dollar per day only pay out if the well can be drilled safe, fast and precise. Downhole sensors and downhole communication are therefore of huge importance to the economic feasibility as well as to the overall success of these projects. But still today it is a critical issue to place sensors downhole where they are exposed to the harsh environment involving high pressures, temperatures and vibrations.

Having once managed to acquire data near the bit, it is as well a challenge to get the data to surface in an acceptable lag time. Having an enormous amount of information available makes it necessary to have a powerful telemetry system. Mudpulsing therefore delivers by far no acceptable transfer rate. Also two way communication as well as power supply for downhole tools would be desirable. To this the wired drillpipe technology might deliver a solution.

R&D work is necessary on this topic. An issue is how to protect power and telemetry lines as well as electronics and sensors downhole. One possible solution is the installation of a thin-walled liner tube inside the drillpipe. Thereby an annular space can be created. It is of huge importance that this space is sealed against the inner pressure inside the drillstring.

Project and Thesis Objectives

The target of this thesis project is to design and layout a test bed in order to pressure test such an inner liner assembly inside a drillpipe. This should give a pressure rating as limitation for the applicability of that kind of advanced drillstring technology.

has not to take up any load or inner pressure itself because the filler material in the annulus transmits the internal pressure outwards to the drillpipe wall, the E235 having a minimum yield strength of 235MPa appears as more practicable solution.

The material E235 was also chosen to ensure good weldability. This is of major importance because at the front and at the end of the tube components for fixation and sealing the assembly inside the drillpipe are welded on.

At the box-end of the inner liner tube, a fixation-nut [2] is welded on. By this nut the liner is fixed and secured inside the drillpipe upset by screwing. Therefore the nut has an external thread of the size M106x3 that can be left-handed screwed into the corresponding internal thread that is cut into the box-type tool joint. The liner system is so kept in place in the drillpipe. At the same end of the nut also a left-handed internal thread of the size M80x3 is cut in its inner wall.

The other end of this nut – that is welded on the inner liner tube – has the same outer diameter as the liner, but the inner diameter is reduced. This reduced section is of major importance: In that region where the bore of the nut is reduced compared to the inner diameter of the liner pipe, the filler material in the annulus can be absent. This can happen if the pipe is suspended vertically in the wellbore and due to (bottom hole) vibration and forces on the pipe the filler material is compacted. This degree of compaction might not be achieved during the process of filling the annulus, so it is important to account for this additional compaction that might turn up during the drilling process. If the filler material is absent in the annular space, the wall thickness of the inner liner would not be sufficient to stand the inner pressure. This would lead to a tensile failure (burst) of the liner pipe and the breakdown of the assembly.

There are four through borings at the face of the nut. These allow access to the annulus and are used for filling. They can be plugged by M8 (allen) screws. Three bores at the same font that are not through holes can be used for engaging a cone wrench or installation tool for mounting the nut. Besides that, depending on the purpose of the inner liner assembly, the nut can have several other bores on the front to provide connectivity (data, power...) to the next pipe in the drillstring.

The nut should be manufactured out of round E355 steel again having an ultimate stress limit of 450MPa and a minimum tensile strength of 355MPa. Here again the weldability is of major importance and therefore the E355 was chosen instead of tempering steels which would need heat treatment after welding what would be difficult and cost intensive, not only because of the length of the inner liner of almost nine meters.

At the other end of the liner pipe also a nut [3] is welded on. This nut is of the same outer and inner diameter as the precision tube. The end of the nut offers a M75x2 internal thread at a slightly enlarged outer diameter. For this second nut the same material as for the other is used. This nut offers the port for the pin [4] that is screwed in the nut to compress the metal seal rings [5] between.

The pin is again of E355, but can also be made of steel types having higher strength because this part is just screwed into the liner system and not welded on it. The pin has some gaps milled at the end. These cuts are necessary to be able to engage a certain switch for screwing the pin into the nut.

Between the pin and the nut, the metal sealing rings are compressed. These are two wedge shaped rings – one inner and one external ring. The rings are different in shape: The outer ring offers a plain outer circumferential. When screwing the pin in the nut, the external ring is pushed along the internal ring. By expansion the external ring is pressed against the inner wall of the drillpipe (inner tool joint wall) and thereby creating a seal.

These sealing rings are probably the most crucial components in the whole liner assembly design because they have to seal against the high inner pressure of the mud that is pumped through the drillstring. Therefore the shape and tolerances, the steepness, the material selection as well as the heat treating and surface finishing is of extreme importance. As suggested by the designers, the material to choose for manufacturing is tempering steel 4140 (equal to the old fashioned trade name V320) having an ultimate tensile strength of 980MPa and a minimum

yield strength of 885MPa. The hardness should range between 56 to 62 after Rockwell and a hardening depth of 0.5 to 0.8mm is recommended. The surface roughness should be 1.25.

To connect the inner liner tubes in a drillstring or inside a stand of drillpipes to each other, a special system is used.

Therefore a protective bushing [6] is fixed in the inner thread of the nut at the box-end of the liner tube. When making a connection and tightening the pin of the subsequent drillpipe in the box of the drillpipe that is secured in the rotary table on the rig, the nose of the protective bushing is engaged inside the very end of the pin of the subsequent pipe.

This protective bushing is in fact a hollow cylinder with an inner diameter that is equal to the smaller sized bore of the fixation-nut and an outer diameter of 81mm. Having two different ends the one end offers an external left-handed M80x3 thread having a special shaped nose at the front. This end is screwed in the corresponding internal thread of the nut and creating a hydraulic seal. On the other end of the protective bushing a sophisticated nose is manufactured. This nose slides, as already mentioned before, in the pin of the subsequent drillpipe when two pipes are connected. Therefore the pin face of the tool joint is customized with a special tilted plane. When making a connection the nose of the bushing moves along this plane inside of the pin end until a certain degree of compression is reached. When the nose is in seat inside the pin, a seal again is created. The shape of the nose is a central design feature and was changes several times throughout the design process.

Again some gaps at the face of the nose end of the protective bushing are used to engage the installation switch to screw the protective bushing in the fixation-nut of liner system. As material again steel 4140 (also known as V320) is used. The hardness (especially important at the nose end of the protective bushing) should range between 56 to 65 HRC (test and scale after Rockwell). The left-handed threads at the box-end of the liner system ensure that the sealing at the pin-end is not unscrewed or loosened when installing the protective bushing. Not only this component, but all parts having threads (the liner nuts and the pin) should be zinc phosphate coated.

The Liner Tube

Deformation Calculation

As stated before, the thin walled inner liner would not be able to stand the inner pressure inside the drillpipe alone. Therefore the filler material is placed to avoid the expansion of the liner tube and to transmit the pressure towards the wall of the drillpipe that is designed for standing those high internal pressures. Nevertheless it is also important to know how the liner tube would behave if there is a cavity inside the filler material due to vibration, forces and gravitation.

As long as $OD/ID < 1.2$ is valid (like it is the case here with $OD/ID = 80/76 = 1.05$) for a thin-walled tubular, the boiler formula could be applied to determine the stresses inside the walls.

The axial and the tangential stresses are calculated [3]:

Liner tube geometry and input data:

- E235 with R_e : 235N/mm² and ν : 0.28
- OD: 80mm
- ID: 76mm
- s: 2mm wall thickness
- p_i : 500bar assumed inner working pressure, p_o : 1bar assumed outer pressure
- E: 2.1×10^5 N/mm² Young's Modulus

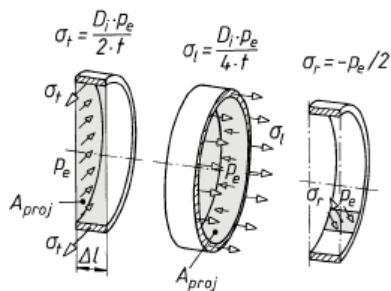

$$\sigma_t = \frac{p * D}{2 * s} \quad (\text{Eq. 1})$$

$$\sigma_a = \frac{p * D}{4 * s} \quad (\text{Eq. 2})$$

$$D = \frac{(D_a + D_i)}{2} = D_a - s \quad (\text{Eq. 3})$$

Figure 2: Stresses in Pipe Wall [4]

Wherein:

σ_t ... Tangential stress [N/mm²]

σ_a ... Axial stress [N/mm²]

p_i ... Inner pressure [N/mm²]

D ... Average Diameter [mm]

s ... Wall thickness [mm]

OD ... Outer Diameter [mm]

ID ... Inner Diameter [mm]

Resulting with an average diameter of 78mm in a σ_t of 975N/mm² and a σ_a of 487.5N/mm². The equivalent stress after von Mises is:

$$\sigma_v = \sqrt{\sigma_t^2 + \sigma_a^2} = 1090 \text{ N/mm}^2 \quad (\text{Eq. 4})$$

Also the radial deformation can be calculated as shown below [4]. But this would not make sense here because the equivalent stress is by far more than the allowable stress for E235 of 156N/mm² considering a safety factor of 1.5 (what is not too conservative). So the inner liner would burst.

$$\Delta r_x = \frac{p_i * r_x * r_i^2}{E * (r_a^2 - r_i^2)} * \left[\frac{r_a^2}{r_x^2} * (1 + \nu) + 1 - \nu \right] \quad (\text{Eq. 5})$$

Wherein:

Δr_x ... Change of radius at radius x [mm]

r_i ... Radius inner wall [mm]

r_o ... Radius outer wall [mm]

r_x ... Radius at radius x [mm]

p_i ... Pressure inner wall [N/mm²]

p_o ... Pressure outer wall [N/mm²]

E ... Young's Modulus [N/mm²]

ν ... Poisson's Ratio [-]

From that on also the required wall thickness can be calculated [4]:

$$s_{min} = \frac{p * D}{2 * \sigma} + s_1 + s_2 \quad (\text{Eq. 6})$$

Wherein:

s_{min} ... Required wall thickness [mm]

p_i ... Inner pressure [N/mm²]

D ... Average diameter [mm]

σ ... Max. allowable stress [N/mm²]

s_1 ... Accounting for tolerance errors [mm] for $s < 10$: 0.35, for $s > 10$: 0.5

s_2 ... Accounting for corrosion and erosion [mm] from 0 for stainless steel to 1 for ferritic steel

OD ... Outer Diameter [mm]

ID ... Inner Diameter [mm]

The required wall thickness at a safety of 1.5 would be around 12.5mm.

Pressure Loss Calculation

Having the inner liner assembly installed, the inner diameter of the 5in, 19.5lb/ft drillpipe reduces from 108.6mm to 76mm. This gives a higher friction pressure loss. Therefore it is necessary to determine the additional pressure drop and to evaluate if it is possible to drill the target well of 5000mMD (3000mTVD, 2000m departure).

NB: The following calculations have been done using an excel spreadsheet for well planning using a conservative Newtonian Modell. The tool joints are added at the bottom of the drillstring.

Example Well – 3 Sections

At first a normal well plan for a 3000m deep almost vertical wellbore using 5in drillpipe is calculated and the pressure losses for the normal drillpipe (DP) in comparison with the modified design are evaluated (in both cases the tool joints are also taken into account). The well is designed to be drilled in three sections with a medium size land rig – the Bentec EuroRig250. This rig is equipped with intermediate strong pumps with a max. pressure output of approximately 350bar (incl. safety). Larger rigs would have mud pumps up to 500bar what is today more or less the best you can get in the industry. The mud program is standard for that type of well as well as the operating parameter. The bit performance, hole cleaning and hydraulics are optimized for each case. Therefore the differences in pressure losses are just showing a trend and not the absolute difference between the standard DP and the modified DP.

Input Data

Drillstring Data

- 1) 5in DP, G105, IEU NC50, 19.5lb/ft (ID 108.6mm)
- 2) 5in DP, G105, IEU NC50 (ID 76mm)
- 3) DC 6.75in, ID 3, 105lb/ft

Surface Equipment

2x Triplex Bentec T-1600-AC
1,600HP
350bar max. pressure output

Surface Section

Wellbore Geometry

Conductor: 16in
Set @ 50m
15in OH Size (assumed average)
drilled with 14.5in bit with 2x 16/32in + 4x 12/32in nozzles
720mMD (720mTVD)

Mud Properties

Bentonite Mud
 MW 1200kg/m³
 PV 30cp
 YP 12lb/100ft²

Operating Parameters

Flow rate 3500l/min

Pressure Losses standard 5"DP

System Pressure Losses	Pressure [bar]	Horsepower [hp]	%
Surface Pressure Loss	3.3	25.7	3%
Pipe Pressure Loss	43.1	337.4	36%
Bit Pressure Loss	73.4	573.9	61%
Annular Pressure Loss	1.1	8.9	1%
Total (SPP)	120.9	945.9	100%
Safety Factor	20%	20%	
Required Pump Capacity	145.1	1136.1	

Pressure Losses modified 5"DP

System Pressure Losses	Pressure [bar]	Horsepower [hp]	%
Surface Pressure Loss	3.3	25.7	1%
Pipe Pressure Loss	212.4	1662.0	73%
Bit Pressure Loss	73.4	573.9	25%
Annular Pressure Loss	1.1	8.9	0%
Total (SPP)	290.2	2270.5	100%
Safety Factor	20%	20%	
Required Pump Capacity	348.2	2724.6	

Intermediate Section

Wellbore Geometry

Surface Csg: 11 3/8in, N-80, 60lb/ft

Set @ 700m

10 5/8in OH Size (assumed average)

drilled with 10 5/8in bit with 3x 12/32in + 1x 13/32in nozzles (standard drillstring)

drilled with 10 5/8in bit with 3x 14/32in + 1x 15/32in nozzles (modified drillstring)

2520mMD (2520mTVD)

Mud Properties

Bentonite Mud
 MW 1200kg/m³

PV 15cp
 YP 9lb/100ft²

Operating Parameters

Flow rate 1890l/min (standard drillstring)
 Flow rate 1700l/min (modified drillstring)

Pressure Losses standard 5"DP

System Pressure Losses	Pressure [bar]	Horsepower [hp]	%
Surface Pressure Loss	0.9	4.0	1%
Pipe Pressure Loss	47.8	202.1	39%
Bit Pressure Loss	70.1	296.2	56%
Annular Pressure Loss	5.4	22.6	4%
Total (SPP)	124.2	524.9	100%
Safety Factor	20%	20%	
Required Pump Capacity	149.1	629.6	

Pressure Losses modified 5"DP

System Pressure Losses	Pressure [bar]	Horsepower [hp]	%
Surface Pressure Loss	0.8	3.0	0%
Pipe Pressure Loss	176.7	671.6	83%
Bit Pressure Loss	31.0	117.8	14%
Annular Pressure Loss	5.3	20.1	2%
Total (SPP)	213.8	812.4	100%
Safety Factor	20%	20%	
Required Pump Capacity	256.5	974.9	

Production Section

Wellbore Geometry

Intermediate Csg: 9 5/8in, C-95, 58.40lb/ft
 Set @ 2500m
 9in OH Size (assumed average)
 drilled with 8.5in bit with 2x 11/32in + 1x 10/32in nozzles (standard drillstring)
 drilled with 8.5in bit with 2x 11/32in + 1x 12/32in nozzles (modified drillstring)
 3210mMD (3210mTVD)

Mud Properties

Bentonite Mud
 MW 1480kg/m³

PV 20cp
 YP 18lb/100ft²

Operating Parameters

Flow rate 1135l/min (for both drillstrings)

Pressure Losses standard 5" DP

System Pressure Losses	Pressure [bar]	Horsepower [hp]	%
Surface Pressure Loss	0.5	1.2	0%
Pipe Pressure Loss	31.8	80.7	21%
Bit Pressure Loss	96.3	244.3	63%
Annular Pressure Loss	23.2	58.7	15%
Total (SPP)	151.7	385.0	100%
Safety Factor	20%	20%	
Required Pump Capacity	182.1	462.0	

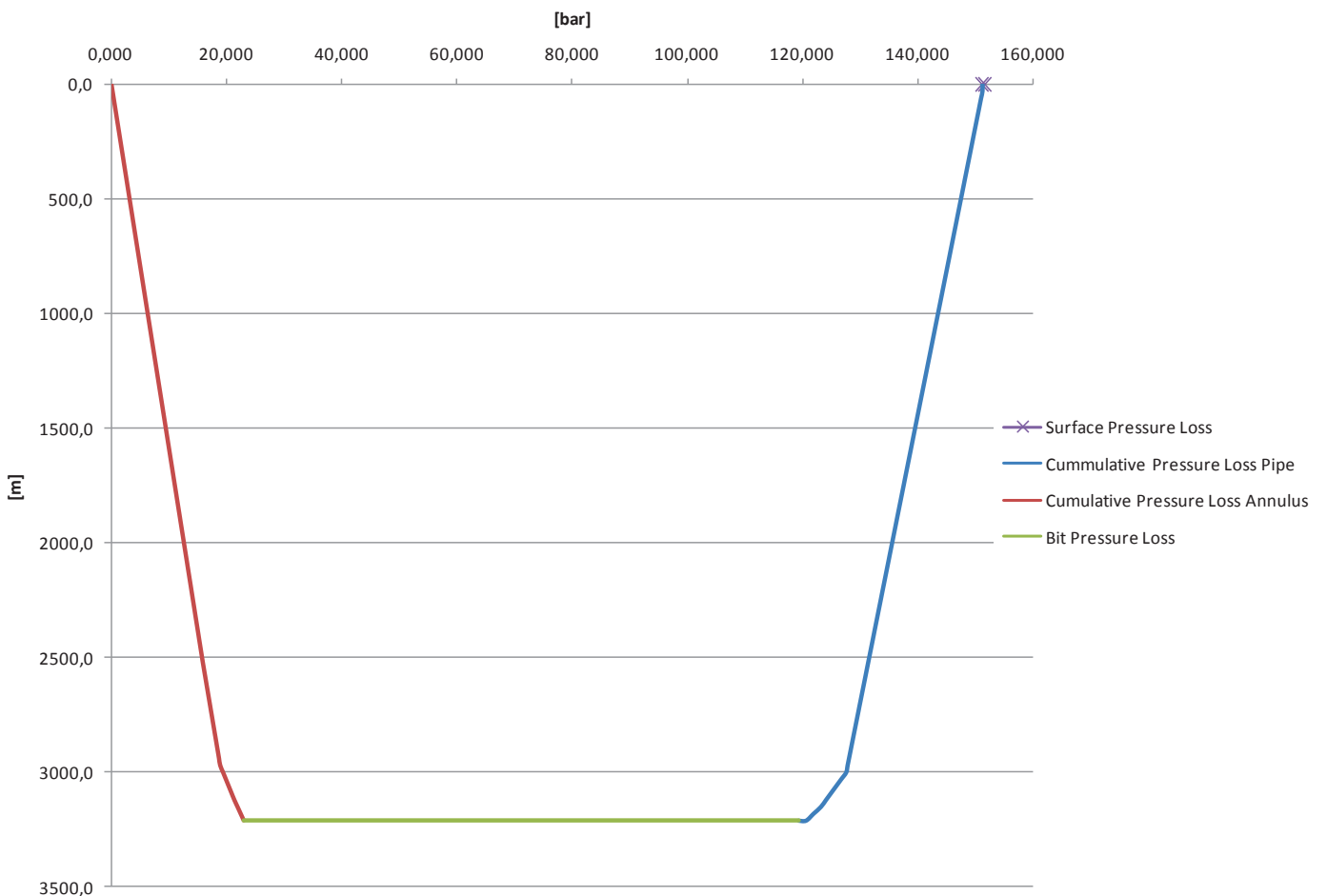

Figure 3: Pressure Profile Production Section – standard DP

Pressure Losses modified 5"DP

System Pressure Losses	Pressure [bar]	Horsepower [hp]	%
Surface Pressure Loss	0.5	1.1	0%
Pipe Pressure Loss	129.9	329.6	52%
Bit Pressure Loss	96.3	244.3	39%
Annular Pressure Loss	22.2	56.3	9%
Total (SPP)	248.8	631.3	100%
Safety Factor	20%	20%	
Required Pump Capacity	298.6	757.5	

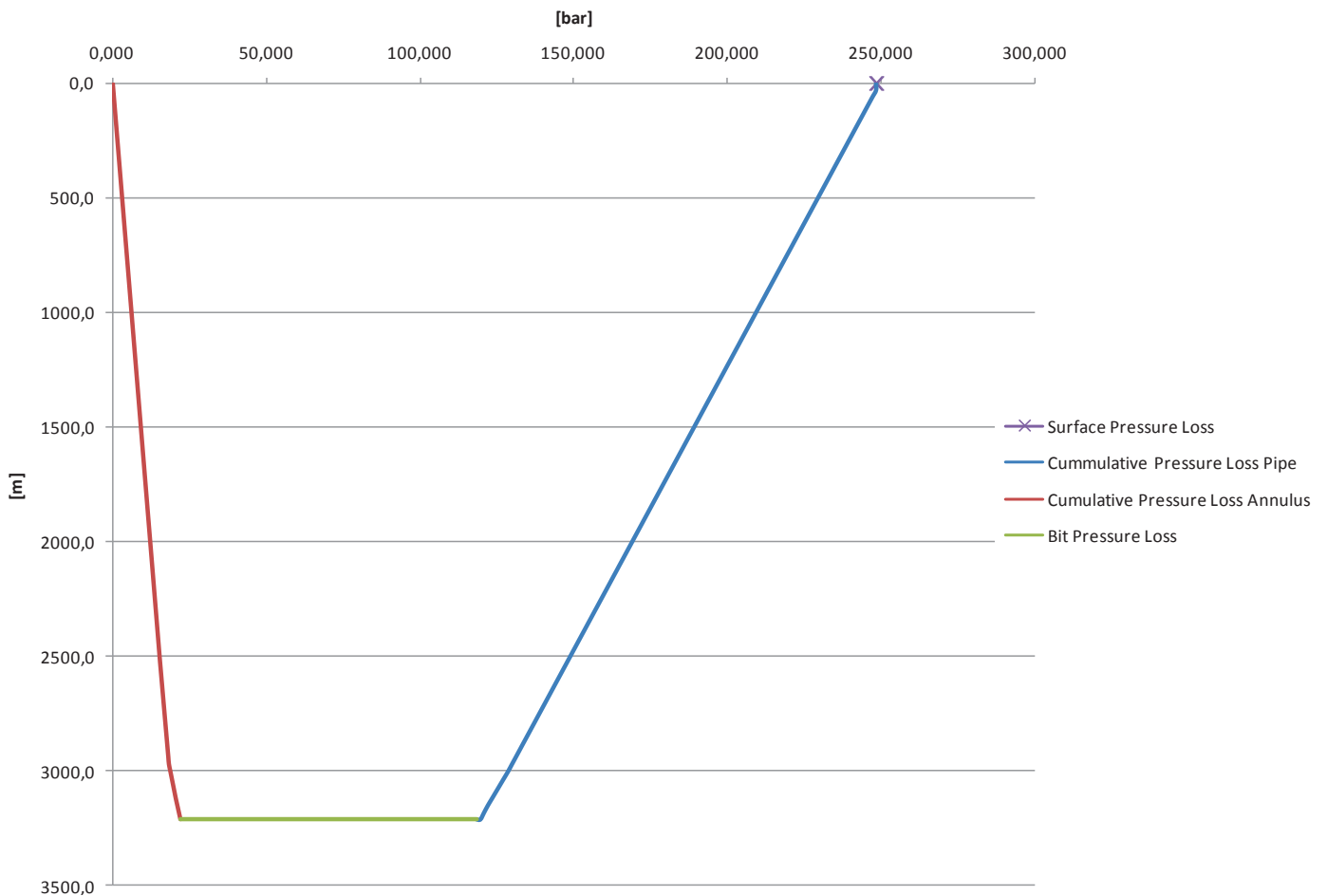

Figure 4: Pressure Profile Production Section – modified DP

Scenario 5000m well

Objective

The objective is to calculate the pressure profile of a 5000m deep wellbore (3000mTVD) using a standard 5in drillpipe string. Afterwards the results are compared to the pressure profile of the

same wellbore but using the modified 5in drillpipe instead.

Input Data

Wellbore Geometry

Csg: 9 5/8in, P-110, 47lb/ft

Set @ 3700m

9in OH Size (assumed average)

drilled with 8.5in bit with 3x 12/32in nozzles

TD 5040mMD

Drillstring

1) 5in DP, G105, IEU NC50, 19.5lb/ft (ID 108.6mm)

2) 5in DP, G105, IEU NC50 (ID 76mm)

Surface Equipment

2x Triplex Bentec T-1600-AC

1,600HP

350bar max. pressure output

Mud Properties

Bentonite Mud

MW 1300kg/m³ (3000mTVD with normal gradient results in 300-500bar formation pressure)

PV < 15cp

YP 18-20lb/100ft²

Operating Parameters

Flow rate 1100l/min

Calculation Results

5in DP standard

System Pressure Losses	Pressure [bar]	Horsepower [hp]	%
Surface Pressure Loss	0.4	0.9	0%
Pipe Pressure Loss	36.3	90.9	31%
Bit Pressure Loss	45.7	114.3	39%
Annular Pressure Loss	35.0	87.6	30%
Total (SPP)	117.3	293.8	100%
Safety Factor	20%	20%	
Required Pump Capacity	140.8	352.5	

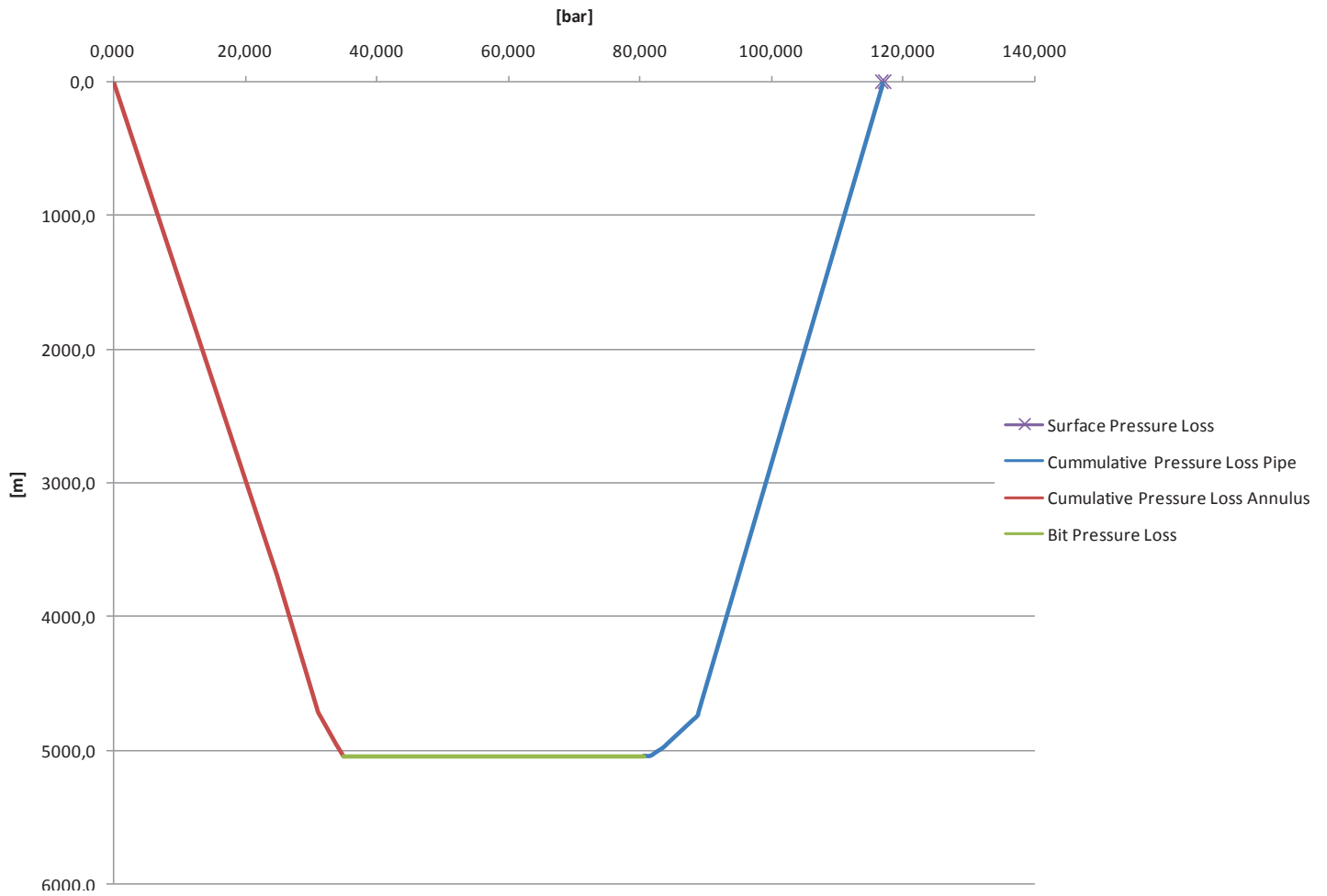

Figure 5: Pressure Profile 5000m Well – standard DP

5in DP modified

System Pressure Losses	Pressure [bar]	Horsepower [hp]	%
Surface Pressure Loss	0.4	0.9	0%
Pipe Pressure Loss	164.9	413.0	67%
Bit Pressure Loss	45.7	114.3	19%
Annular Pressure Loss	35.0	87.6	14%
Total (SPP)	246.0	615.8	100%
Safety Factor	20%	20%	
Required Pump Capacity	295.2	739.0	

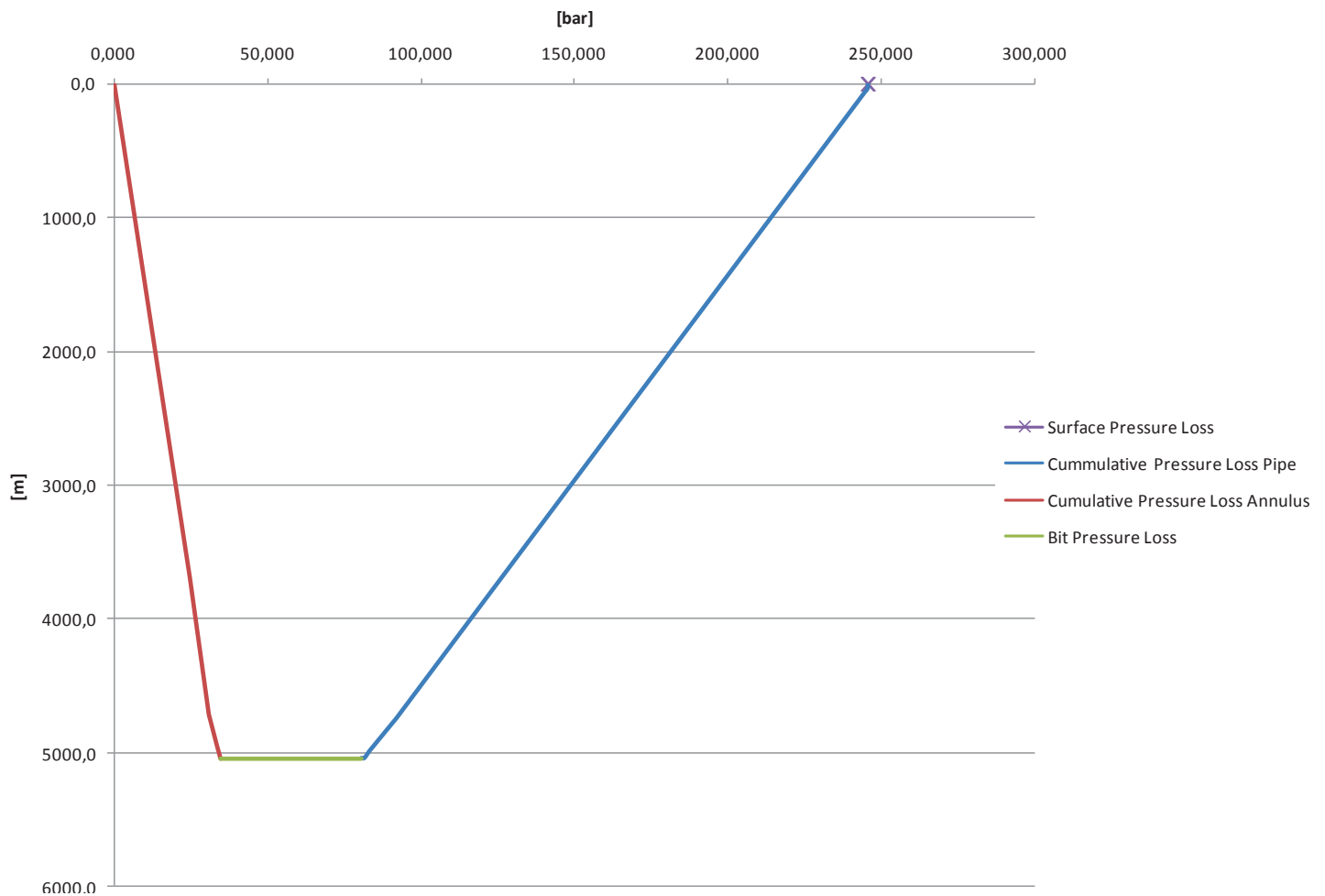

Figure 6: Pressure Profile 5000m Well – modified DP

Here a typical wellbore section down to 5000mMD drilled with a medium size standard rig (Bentec EuroRig250t) with common mud and operating parameters and optimized hydraulics is calculated. Using the modified 5in DP (with the reduced inner diameter) shows a significant higher pipe pressure loss: 165bar compared to 36bar for the standard 5in DP.

The major reason for the rather strong increase in pipe pressure loss for the smaller ID DP is the flow rate. The combination of the 5in DP together with the 8.5in bit makes it necessary to adjust the lower flow rate limit to above 1100l/min to keep the cutting lifting velocity in the annulus above the required 120ft/min.

Smaller bit sizes (down to 6 5/8in are possible for 5in DP) decrease the annular volume and smaller flow rates could be used. Here a standard csg/openhole-size example was calculated. But also a low-clearance solution would minimize the pressure loss by lower flow rates again because of a smaller annular volume.

It can be stated: The smaller the flow rate the smaller the differences in pipe pressure losses between the standard drillpipes and the modified design. Also in normal drilling operations flow rates up to 2000l/min or even 3000l/min are common and could impose a limitation to the application of the modified drillpipe. But still, the 5,000m target well can be drilled.

Pressure Loss vs. Flow Rate Comparison

To determine the absolute difference in pressure loss between the standard 5in DP and the modified 5in DP having the inner liner with the reduced diameter, it is necessary to compare the pressure losses inside the drillpipes on their own without optimizing hydraulics and without altering any parameter that might influence or mask the actual results. Therefore now the pressure losses inside a drillstring of a certain length consisting only of drillpipe (including the tool joints but no bit) are calculated. The pressure losses of a string of the standard 5in drillpipe are compared to the losses inside a string of the 5in modified drillpipe by calculating three different lengths of the drillstring (1000m, 2000m and 3000m) and using three different muds having different properties. The following muds are used:

Mud	MW [kg/m ³]	PV [cP]	YP [lb/100ft ²]
1	1100	5	15
2	1200	15	18
3	1400	30	20

In the chart below, the pressure losses in dependence of the flow rate are shown. A multiplier (factor) is showing the ratio of the pressure losses of the string of the modified drillpipe to the pressure losses of the string consisting of the standard drillpipe. It is obvious that when the flow rate is high enough that in both types of drillstrings the flow would be turbulent, the pressure losses in the modified drillpipes are roughly about 5times higher than the ones in the standard pipes. The results are showing that this behavior is almost independent of the length of the drillstring as well as independent of the mud properties (charts for all combinations are shown in Appendix A).

Example: 2000m length and Mud2

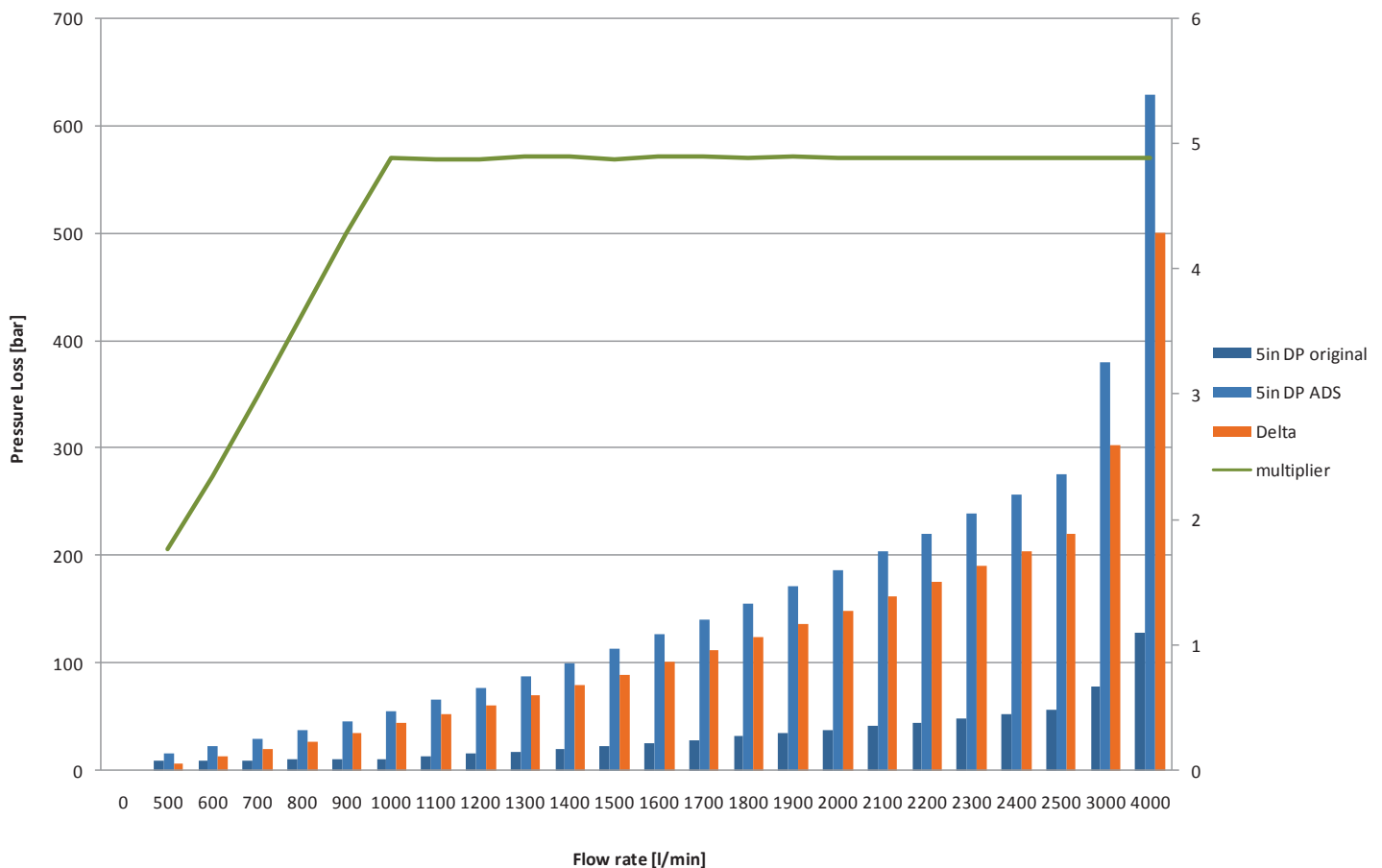

Figure 7: Pressure Loss Comparison in dependence of the Flow Rate

In that case the approximate transition from laminar to turbulent flow in the standard DP is around 1000 l/min where else the transition in flow behavior for the modified DP would be around 500 l/min.

As turbulence criteria that flow pattern that gives the greater frictional pressure loss is assumed (compare Bourgoyne et al. "Applied Drilling Engineering", p155).

Here can be stated that a factor of 4.88 between the pressure losses of the modified drillpipes to the standard pipes is valid for flow rates higher than 1000 l/min.

Multipliers:

Mud	1000m	2000m	3000m
1	5.07	4.89	4.83
2	5.06	4.88	4.83
3	5.07	4.89	4.83

E.g.: Drilling with a 3000m drillstring and pumping Mud Nr.3, the pressure losses inside the drillstring consisting of the pipes of the modified design would be 4.83 times higher than the pressure losses inside the drillstring consisting of the standard 5in drillpipe.

Pressure Loss in bar/1000m:

5in Standard DP	1000l/min	2000l/min	3000l/min
Mud 1	4.1	13.3	27.1
Mud 2	5.6	18.7	38.1
Mud 3	7.4	25.0	50.8

5in Modified DP	1000l/min	2000l/min	3000l/min
Mud 1	20.1	67.6	137.4
Mud 2	28.2	94.9	193.0
Mud 3	37.7	126.7	257.6

Conclusions

- For low flow rates the differences in pressure losses are not sever. Today larger rig pumps have a max. pressure output of 500bar and can handle the additional pressure loss.
- Also in normal drilling operations flow rates up to 2000l/min or even 3000l/min are common and these higher flow rates could impose a limitation to the application of the modified drillpipe.
- But still it is no problem to drill a 5000mMD well with a 8.5in bit (8.5in is relatively large for drilling a production section in that depth. Normally bits are smaller, what makes the hydraulics design easier)
- For higher flow rates (approximately starting from pump rates of 1000l/min upwards), the pressure loss in the modified drillpipe is about 5times higher than for the standard 5in drillpipe. This rule of thumb is only valid if the flow rate is high enough that in the standard drillpipe as well as in the modified drillpipe the flow would be turbulent.

- For operating the modified drillpipes: Trying to keep the flow rate to a minimum (smaller annular space...) although if the bit performance suffers. It is easier to optimize bit performance with the standard drillpipe design because of having higher flow rates available. If the flow rate is too low for a good hole cleaning – for lifting the cuttings to surface – then think about pumping viscous pills etc.
- Rules of thumb, like there should be around/ at least 50-60% of the overall pressure loss at the bit cannot be used for the modified drillpipe. Therefore the bit performance should be optimized by adjusting the bit to 2-5HHP/in²
- Adjust the plastic viscosity and the specific gravity of the mud to the lower limit
- The modified 5in DP can be – regarding the inner diameter – compared to a 5in heavy weight (5x3 HWDP). If possible use larger drillpipe sizes having the inner liner design. E.g. 5 ½ in.
- In case of revision of the design, do not further reduce the ID of the liner tube to increase its wall thickness. A reduction of the ID to 76mm for example would result in more than 6times higher pressure losses.

The Liner Sealing

One of the most important issues during the design process of the inner liner assembly is to guarantee that the annulus between the inner liner tube and the drillpipe is sealed against the hydraulic pressure inside the drillpipe that is caused by the mud that is pumped through the drillstring. This inner pressure depends on the one hand on the hydrostatic pressure caused by mudweight and the TVD when the pumps are stopped and on the other hand on the pump pressure inside the drillstring when fluid is circulated down the well. These pressures are mainly influenced by the fluid properties, the flow rate and the inner diameter of the drillstring. The inner pressure in a drillpipe can vary over a wide range but for normal drilling operation a maximum of 550bar inner pressure can be used as a fair assumption [5]. Certainly higher pressures can turn up, but for designing the seals a pressure of 500bar inside the drillpipe was used for calculation.

On the box-end of the drillpipe, the inner tube is screwed into the tool joint and by that fixed and kept in position.

On the other end the liner is sealed by two metal rings that are moved against each other, thereby expanded and pressed towards the drillpipe wall. In detail: A pin having an external thread is screwed in the corresponding nut that is welded on the liner tube. Between nut and pin the two metal rings are placed. The rings are moved against each other for 0.1mm what can be achieved by applying torque to the pin in a range between 790Nm for a friction coefficient (μ) of 0.1 (bare steel on steel oiled or MoS_2 ...) to 2370Nm for a μ of 0.3 (bare steel on steel slightly lubricated). Also the inner pressure helps to force the rings against each other and against the drillpipe wall. By that a seal is created [1]. The figure below is showing the distribution of the contact pressure of that seal group calculated by finite element analyses [6].

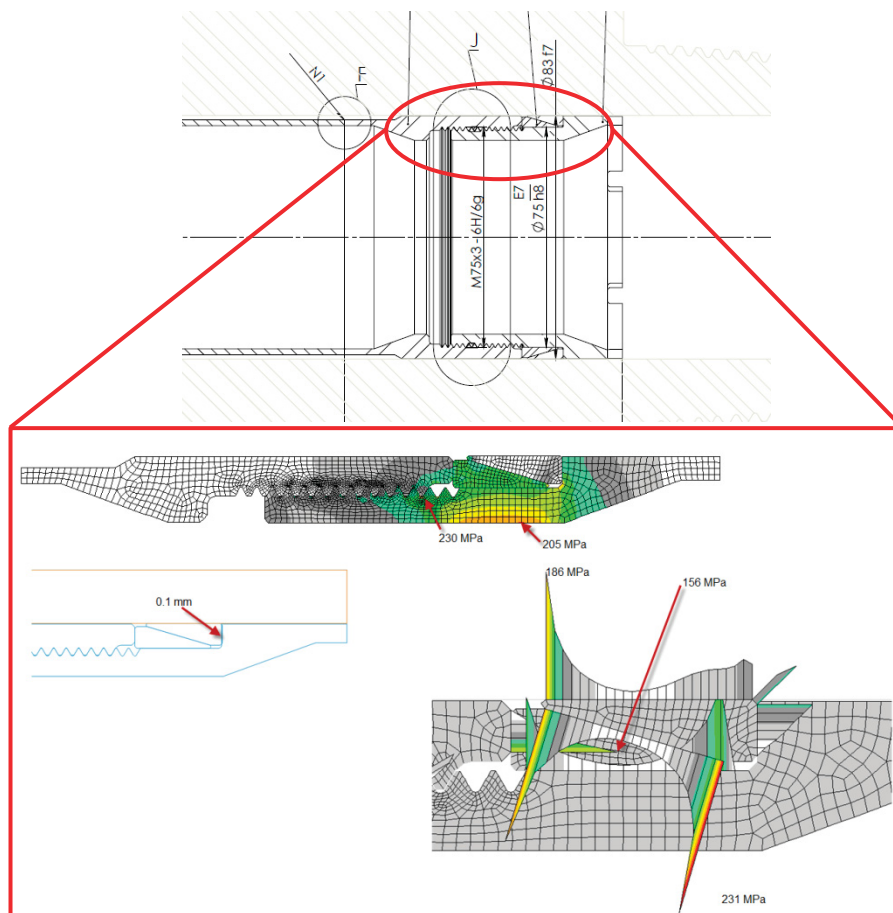

Figure 8: FEA for Seal Group Liner Nut x Pin with Metal Seal Rings [6]

This mechanical sealing mechanism is not rigid and therefore having the advantage that the sealing can slide some small distance along the drillpipe wall in case of elongation and compression of the liner tube due to thermal changes (e.g. geothermal application) or mechanical influences like forces on the drillstring (e.g. bending). If both ends would be fixed like the other end that is screwed inside the tool joint, severe stresses due to the thin wall size of the liner would turn up and could lead to a failure of the inner liner system.

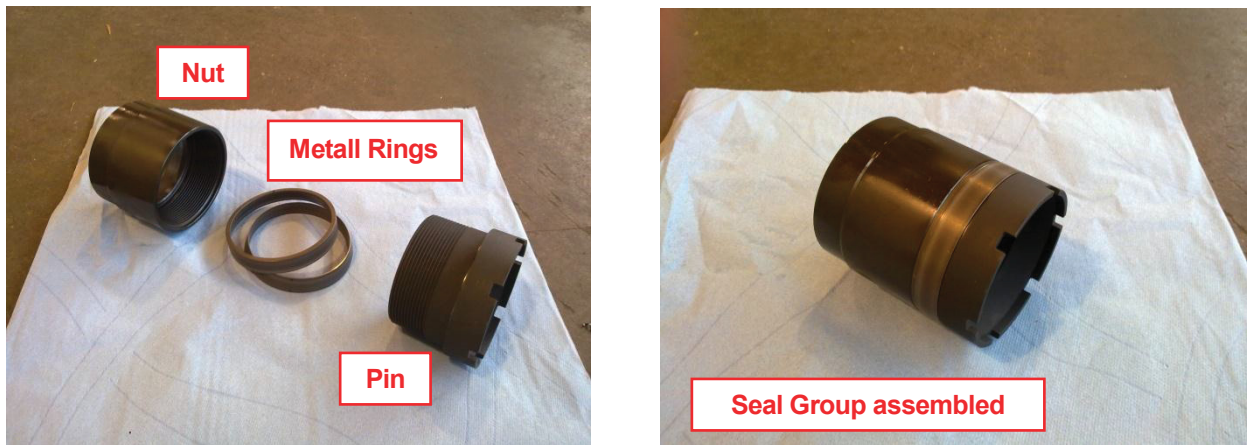

Figure 9: The Components of the Sealing Assembly – Nut, Inner and External Ring, Pin

The second sealing mechanism used for the liner system is only slightly different. Here again metal surfaces are pressed versus each other and by that a hydraulic seal is created. This method is used at both ends of the protective bushing: the one end has a nose that is screwed inside the nut of the liner tube and on the other end also a nose is placed inside the pin end of the subsequent pipe. These both seals were again calculated by using finite element analyses. The distribution of the contact forces is shown in the figures below [1].

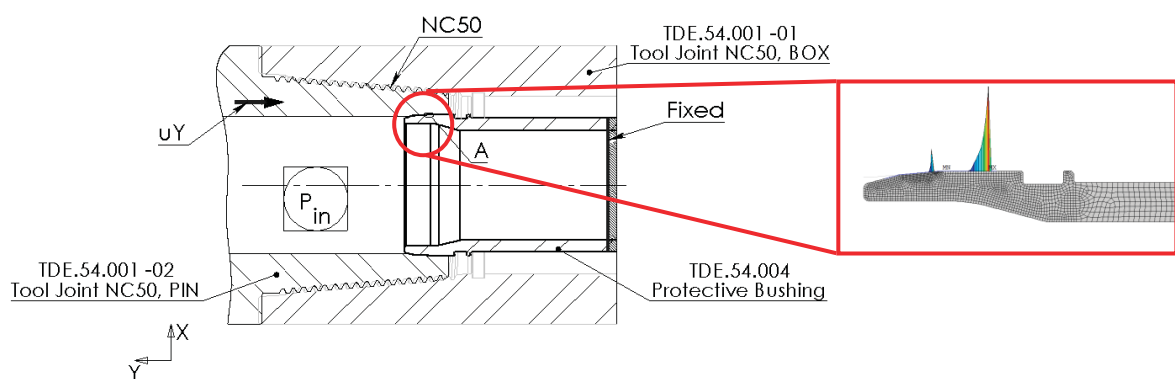

Figure 10: FEA for Seal Group Protective Bushing x DP [7]

A seal is created here for an axial tightness (movement of the metal surfaces vs. each other) in the range from 0.178mm to 1.2mm.

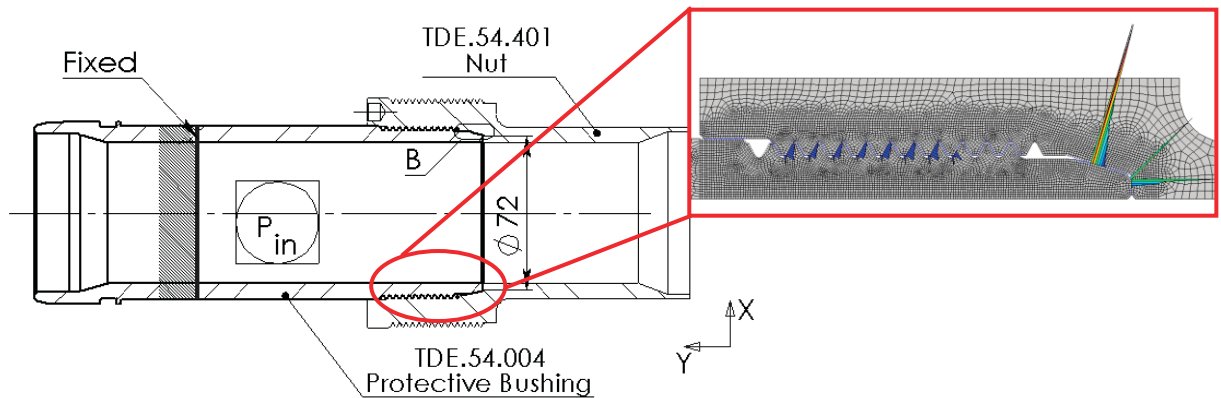

Figure 11: FEA for Seal Group Protective Bushing x Liner Nut [8]

To create a sealing here, the protective bushing needs to be installed with a torque between 549Nm (μ of 0.1) and 1656Nm (μ of 0.3).

The Annular Filling Material

Required Properties of the Filler Material

The main duty of the annular filling material is to transmit the pressure of the drilling mud that is exerted on the inner wall of the liner tube to the inner wall of the drillpipe. The thin-walled liner would not be able to stand these pressures alone and would expand. Therefore it is the most important that the filler material has a high compressive strength. Also the grain size is very important. The bigger grains should be less than one mm in diameter to be able to fill also the smaller cavities inside the annulus. The grain size distribution should be equal and it is also extreme important that the grains of the filler material are spherically shaped. The better the roundness, the less is the impact of the grains acting on the surfaces of the liner tube. It would not only weaken the material if the grains are pressed into the surface of the liner tube, also installations on the liner like a flat copper cable would suffer from pressing sharp-edged grains on it. As the inner liner assembly could also serve as insulated drillpipe, also the thermal (insulation) properties are important. Last but not least the filler material should be as light as possible, but of course offering a high compressive strength at low specific gravity. Using light weight filler material would lead to a reduction of the weight of the drillpipe per length when floating in mud. This is because the annular volume is now packed by the light filler material instead of being occupied by drilling mud like in a conventional pipe [1].

The following materials were considered as possible solutions: construction sand, fracturing proppants from the E&P industry and ceramic beads. Steel shots and cut wire was not taken into consideration because of their square shape. Polymer granulate that is used for extruding cannot stand elevated temperatures as caused by the geothermal gradient during drilling a well. Also hydraulic oil is not an option because fluid as filler material would make it necessary to install high pressure seals. Fluids in general might seem ideal for filling the smallest cavities but cannot be used as long as they expand under heat [1].

Construction Sand

The main advantage of construction sand is the good availability and the low costs. But a low compressive strength makes it more or less useless.

Fracturing Proppants

High strength proppants like sintered bauxite would offer superior compressive strength at relatively low weight. Also thermal properties of some proppants are excellent for insulation and a round shape is also available. Therefore the following proppant types would be the ideal filler material: Resin coated sand with strength up to 8,000psi, fused ceramics and sintered bauxite ranging approximately from 5,000-10,000psi compressive strength and sintered bauxite with corundum having a compressive strength larger than 10,000psi [9].

Ceramic Beads

Unfortunately proppants are not available in small quantities. Therefore ceramic beads that are used for sandblasting and surface finishing were now chosen as filler material.

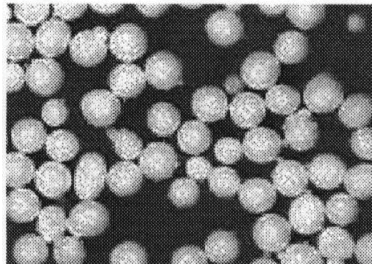

Figure 12: Ceramic Beads as Filler Material [10]

Technical data of the proposed filler material [10]:

- Chemical Analyses: ZrO_2 60-70%, SiO_2 28-33%, Al_2O_3 <10%
- Grain Structure: monoclinic zircon crystal
- Hardness: ca. 700 HV (after Vickers) equal to 60-65 HRC (after Rockwell)
- Specific gravity: ca 3.80kg/l
- Bulk density: ca 2.30kg/l
- Grain size distribution: 250-425 μ m (1% larger, 4% smaller)

Method of Filling

The annular space can be filled by gravity when putting the drillpipe in a vertical position. But also filling the pipe by using a vacuum pump or injection would be an option – this has the huge advantage that it can be done horizontally [11].

Testing Method of Filling

Filling the annular space might be accomplished in an upright position. The four fill-ports in the liner-nut at the box-end are used therefore. To determine the amount of fill ports necessary and to estimate the time how long filling of one drillpipe takes, tests were carried out. In a rubber block a fill port was placed having the standard length, diameter, thread size and thread depth. Concerning friction factors the rubber has similar surface properties like the liner-nut made from steel. Then the ceramic beads, as described above, were poured through the bore by gravity only. The time that a certain amount needed was taken. By knowing the annular volume of the drillpipe, the time that is needed to fill a drillpipe could be calculated. The experimental arrangement is shown in the sketch below.

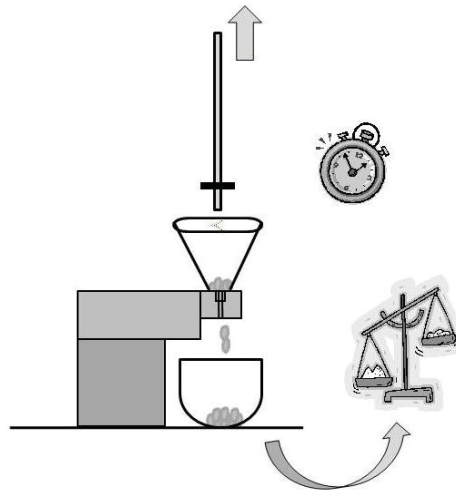

Figure 13: Arrangement for Filling Tests

500g of the ceramic beads were filled in a funnel. A plug was pulled and the test started. After the continuous flow stopped, the time was stopped too. The amount that was gravitated through the fill port during that time was weighted.

As a result, after a few attempts, can be stated that in average 493g of the ceramic beads need 36sec to travel through the bore. This means that the annular volume of the drillpipe of approximately 37.8l (calculated with the suggested liner length and standard upset/drillpipe dimensions) can be filled – considering the bulk density of the beads and by using four bores – in approximately 26.5min. But this is only valid for an upright (vertical) position and without compaction by vibration.

Pros and Cons

Advantages of Inner Liner Assemblies

The inner liner system that is mounted inside a standard drillpipe offers many advantages: An annular space is created that can be used for placing sensors and electronics as well as data transmission and power supply cables. These applications are perfectly protected against the drilling mud as well as against cuttings and mechanical forces on the drillpipe. The liner system also offers advantages if no equipment is placed inside the annulus: Depending on the filler material the buoyant weight of the drillstring can be reduced, vibrations could be dampened and depending on the thermal properties also an insulation for geothermal applications (for cool drilling fluid) is possible.

Disadvantages of Inner Liner Assemblies

The liner system is of cause linked to higher costs per drillpipe but the major downside is that hydraulics are heavily influences and about 5times higher friction pressure losses inside the drillpipe could be observed. For illustration: The geometry of the 5in DP having the inner liner can be compared to a 5in heavy weight drillpipe, having also a 3in bore. These higher pressure losses might be compensated by stronger rig pumps but bit hydraulics and performance due to flow rate restrictions as well as maximum drillable MD could be limited. Also the DP – in air and depending on the filler material – can be up to 40% heavier and the pressure rating is reduced (for burst compared to original drillpipe) [1].

Applications

Insulated Drillpipe

Today already inner liner systems are used to place insulation material at the wall of the drillpipe (Insulated Pipe by Cool Drill Inc. using fracturing proppants as filling material [11]). By that it is possible to use almost every kind of material as insulation material even if it is granular, compacted, uncured or loose.

Wired Drillpipe

Today wired pipes have proven in the field. Normally an armoured cable is tensioned between the upsets of the tool joints (IntelliPipe/IntelliServe by Novatek/NOV – National Oilwell Varco [12]). Having an inner liner system in a drillpipe makes it possible to better protect the cable but also have more and thicker power and data lines.

Sensor Sub

The annular space makes it possible to place all different sensors there with having them sealed against the drilling fluid.

Inner Pressure Test Bed

General Aspects

The target was to pressure test the sealing components of the inner liner system to 700bar (atmospheric back pressure between liner and drillpipe). In order to evaluate the integrity of the assembly this test pressure was selected – as suggested in API Spec 7 for Rotary Drill Stem Elements – above the expected working pressure of 500bar to that the pipe might be subjected during normal drilling operations [13]. The inner working pressure was set to the value of 500bar because on the one hand the liner system should be designed for drilling wells with 5000mMD and 3000mTVD (300-500bar formation pressure considering a normal gradient) and on the other hand, as stated in the literature and in similar R&D projects, the inner pressure in DP seldom exceeds 550bar [11] in normal drilling operations. Modern rig pumps are having a maximum pressure output of 500bar. The maximum standpipe pressure therefore is slightly lower (reduced by safety and surface line losses). This means that the maximum circulation pressure at the very top of the drillstring – where there is no back pressure due to the hydrostatic in the annulus – cannot be more than this value.

In fact there are three crucial points within the liner system (three metal to metal seals that are highlighted by circles in Fig 1.): the nut at the pin-end of the liner having the two metal seal rings, the nut at the box-end of the liner, where the protective bushing is screwed in and the nose of the protective bushing that is engaged with the pin of the subsequent pipe when making connection of two drillpipes on the rig.

Therefore an inner pressure test bed – what is more or less a high pressure test cell – had to be designed. In principle pressure is applied and a drop of the pressure would indicate a leakage somewhere. For safety reasons the pressure is applied by using a hydraulic hand pump with hydraulic oil. Due to the fact that there is more than one sealing within the liner system it turned out to be the best solution to pressure test each crucial element on its own. This allows detecting leakage of the element just by observing a pressure drop. If all elements would be tested in just one pressure vessel a pressure loss would just indicate that there is a leaking part somewhere, but not knowing which sealing is working and which is not. For the three sealing parts, three test cells were built plus one larger inner pressure test bed that allows evaluating the behavior of the liner tube itself (sealing, expansion, deformation, filler material...).

All blueprints are given in Appendix B. For overview and orientation the following the table is given:

Nr	Test Bed	For testing	Blueprints on page	Part List on page
100	Liner+Sealing Tester	Liner Tube, Filler Material, Metal Seal Rings, Pin, Nut	92 (Appendix B)	102 (Appendix C)
200	Sealing-Only Tester	Metal Seal Rings and Pin	93 (Appendix B)	103 (Appendix C)
300	Protective Bushing Tester 1	Nose of Protective Bushing	94 (Appendix B)	104 (Appendix C)
400	Protective Bushing Tester 2	Thread of Protective Bushing and corresponding Nut	95 (Appendix B)	105 (Appendix C)

Sealing-Only Tester

Requirements and Features

At first it is important to pressure test the nut at the pin-end of the drillpipe where metal rings are creating a seal. Because the function of that seal is highly influenced by the shape and the surface finishing of that rings, it is of great importance to test them on their own since some changes on the design might be necessary before the sealing is working. A pin that is screwed into the nut is forcing the rings towards the drillpipe wall what is sealing-off the annular space of the liner system against the hydraulic pressure created by the drilling mud inside the drillstring. Here only a rather cheap and small test cell is built first to allow experiments on the design (shape, material...) of the inner and the outer seal ring without having the costs and handling problems of a larger-sized testing apparatus.

Basic Idea and Function

A pressure cell as shown in the figure below was developed that allows to test this sealing on its own. The test bed is consisting of a pipe (200-01) closed by two end plates (200-02, 03). Inside the pipe the sealing assembly (200-04) is placed.

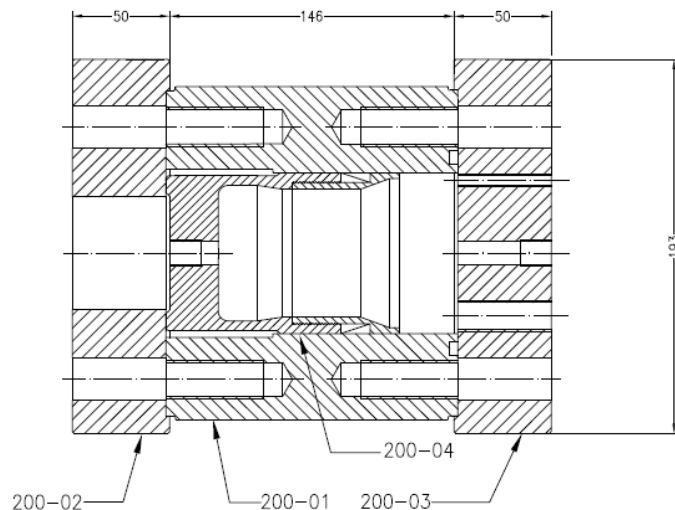

Figure 14: Sealing- Only Test Bed

Therefore a pipe of short length having the same inner diameter as the tool joint at the pin-end of the drillpipe where the sealing is placed is used. On the other end, the pipe has a slightly larger inner diameter. This enlarged ID should make a pressure drop more significant. End plates are covering the front ends of this short pipe. Inside the heavy walled pipe the sealing assembly consisting of nut, pin and the metal rings is placed.

These sealing parts are the same as in the original inner liner design. Only the nut is slightly modified compared to the original design: The original nut – that is more or less a hollow cylinder – has two open ends – one that is welded on the liner tube and one having an internal thread where the pin is screwed in. For the modified nut here the threaded end is the same as for the original but the other side of the nut is closed. This modified nut is manufactured from a full cylindrical piece of steel and not from a pipe what makes it possible to have one side closed without needing welding or screwing. Therefore this closed end can be regarded as perfectly tight and perfectly sealed. So if a pressure drop occurs during testing, the leaking part must be the metal rings. At the closed end of the nut the hydraulic hand pump is directly connected to the inner volume. To have a tight connection between the pump and the modified nut, the surface is rather smooth with a roughness of 1.6. At this end also four shallow bores are places.

These bores serve while installation to counterforce when the pin is screwed into the nut. Since hydraulic pressure is working in all directions, the closed end of the nut might be deformed. To avoid influences on the sealing capacity of the nut and the whole sealing assembly by deformation due to the test pressure, the modified nut has a kind of ring milled at the outer front of the closed end. Only that ring is in contact with the end plate that has a circular opening in the middle. Due to that the modified nut can deform because of the inner pressure without being pressed against the end plate. By this influences due to deformation and axial forces on the sealing rings can be avoided.

In the other end plate openings for filling the pipe with hydraulic oil and for venting trapped air are placed. These openings are plugged with screws. For the filling port a M16 screw of quality 10.9 is used and for the venting port a M6 10.9 screw is used. These screws were selected with the largest possible length to have the best possible sealing there and also to prevent a loosening of the screws by internal pressure. A third opening in this plate is for the pressure gage having a size of G1/4in.

The end plates and the pipe are joined by M20 10.9 screws. On the pin-side, where the sealing assembly is open, an o-ring is placed in a groove inside the front face of the heavy walled pipe. This o-ring has to stand a pressure of 700bar. Therefore self-reinforcing metal o-rings would be the ideal solution that could stand several thousand bars. Due to the high costs for that kind of metal o-rings it was chosen to use rubber o-rings instead. Polyurethane o-rings having a shore A hardness of 95 were selected. The higher the hardness, the higher the pressure rating of rubber sealing rings. 95 A is probably the hardest that is suitable for that kind of application. Although these rings are only rated for pressures of 550-650bar – depending on the manufacturer – a good processing, groove design and installation makes it possible to use that rings up to 1000bar [14]. Therefore it is necessary that the gap between the sealing surfaces is almost zero and that the surface opposite to the groove of the ring is rather smooth with a roughness of about 1.6Ra.

Furthermore the end plates are flattened on one spot at the perimeter to have a stable stand of the test cell during testing.

Mechanical Design and Layout

Main Pipe

The main pipe is seamless E470 (HSB/ 1.0536) with R_e of 470N/mm², the strongest steel grade for pipes that is commercially on stock available. The wall thickness of the pipe is selected to stand a pressure differential of 700bar. An excel-spreadsheet was used that calculates on the basis of the equations that are shown below the equivalent stresses in the wall of the pipe.

Tangential (σ_t), radial (σ_r) and axial stress (σ_a) [N/mm²] for heavy walled pipes [3]:

$$\sigma_t = \frac{1}{(r_a^2 - r_i^2)} * \left[p_a * r_a^2 * \left(1 + \frac{r_i^2}{r_x^2} \right) - p_i * r_i^2 * \left(1 + \frac{r_a^2}{r_x^2} \right) \right] \quad (\text{Eq. 7})$$

$$\sigma_r = \frac{1}{(r_a^2 - r_i^2)} * \left[p_a * r_a^2 * \left(1 - \frac{r_i^2}{r_x^2} \right) - p_i * r_i^2 * \left(1 - \frac{r_a^2}{r_x^2} \right) \right] \quad (\text{Eq. 8})$$

$$\sigma_a = \frac{(p_i * r_i^2 - p_a * r_a^2)}{(r_a^2 - r_i^2)} \quad (\text{Eq. 9})$$

Wherein:

r_i ... radius ID [mm]
 r_o ... radius OD [mm]
 r_x ... radius at position x [mm]
 p_i ... pressure inside [N/mm²] = 700bar
 p_o ... pressure outside [N/mm²] = 1bar

Because the pipe is subjected to inner pressure, the tangential and radial stress will be the maximum at the inner wall of the pipe (the axial stress is the same at all radii).

The equivalent stress is calculated by the vector sum of all three stresses.

$$\sigma_v = \sqrt{\sigma_t^2 + \sigma_r^2 + \sigma_a^2} \quad (\text{Eq. 10})$$

Setting the minimum required safety factor to three and the ID to the required tool joint ID of the original pipe (83mm) where the sealing assembly is placed, the necessary OD of the pipe and by that the required wall thickness was figured out. Looking up the available pipe sizes and taken into account the manufacturing process at the lathe, delivering tolerances as well as design criteria, the pipe dimensions at the position of the smallest wall thickness were calculated.

OD: 171.9mm

ID: 87mm

$\sigma_v = 139.5\text{N/mm}^2$

$$S = \frac{R_e * 0.9}{\sigma_v}$$

S=3

End Plates

For the end plates round bar steel V320 (42CrMo(S)4+QT according EN10083, EN10060) as material was chosen because no welding there is necessary and V320 offers much higher yield strength what is important for holding the lock screws in the end plate.

In this step it is necessary to figure out the required thickness of the end plates so that there is not a joint opening and leakage between end plate and pipe due to deformation caused by the internal pressure. The deformation (f) under pressure applied is calculated according the following considerations [15]:

The end plate on the right side of the design drawing above can be seen as articulate supported disk on that a single force (the inner pressure) is acting.

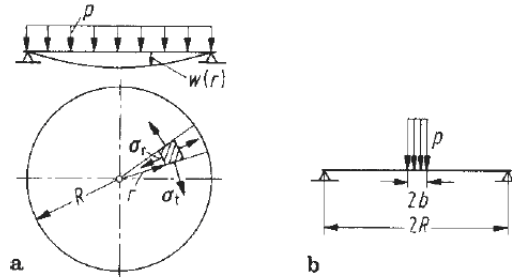

Figure 15: Deformation Calculation of a Circular Plate under Single Force [15]

Wherein according to sketch:

p (pressure applied) = 700bar = 70MPa = 70N/mm²

b = 41.5mm

h = 48mm

R = 96.5mm

E (Young's Modulus) = 2.1×10^5 N/mm²

$$\sigma_t = \sigma_r = 1.95 * \left(\frac{b}{R}\right)^2 * \left[0.77 - 0.135 * \left(\frac{b}{R}\right)^2 - \ln\left(\frac{b}{R}\right)\right] * \frac{p * R^2}{h^2} \quad (\text{Eq. 11})$$

$$\sigma_t = \sigma_r = 149 \text{ N/mm}^2$$

$$f = 0.682 * \left(\frac{b}{R}\right)^2 * \left[2.54 - \left(\frac{b}{R}\right)^2 * (1.52 - \ln\left(\frac{b}{R}\right))\right] * \frac{p * R^4}{E * h^3} \quad (\text{Eq. 12})$$

$$f = 0.062 \text{ mm}$$

Due to the fact that the second end plate is more or less a ring having a large circular opening in the middle, the disk spring equation has to be applied instead of the equations above.

The disk spring equation is given by [16]:

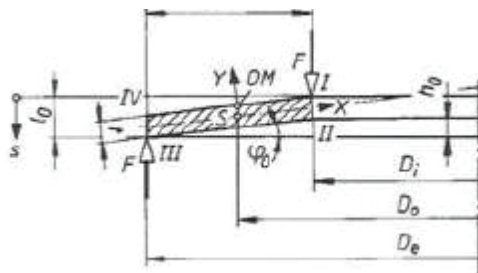

Figure 16: Disk Spring Equation [16]

Wherein:

h_0 (spring deflection) = 0 [mm]

t (thickness of the plate) = 50 [mm]

F (force) = 70 [N/mm²] * 35² * π = 269392 [N]

D_e (external radius of disk) = 193 [mm]

D_i (internal radius of disk) = 50 [mm]

μ (friction factor) = 0.3 [-]

K_1 (statistic table value) = 0.8 (Table 10-8a in Roloff/Matek Formula Book [16] with $D_e/D_i=3.86$)

$$F = \frac{4 * E}{1 - \mu^2} * \frac{t^4}{K_1 * D_e^2} * \frac{s}{t} * \left[\left(\frac{h_o}{t} - \frac{s}{t} \right) * \left(\frac{h_o}{t} - \frac{s}{2t} \right) + 1 \right]$$

(Eq. 13)

Using a try and error solution in Excel the “deformation” s was found.

$s = 0.076\text{mm}$ (for $F = 269392.446\text{N}$; a difference to the actual F of 0.446N)

Screws for Connecting Pipe and End Plates

Screwing depth:

Recommended minimum screwing-in depth for 10.9 screws is calculated by 1.5 times the nominal diameter: $1.5 \times 20 = 30\text{mm}$ (actual in the design 40mm)

Static safety for M20x2x90 10.9 regular threaded screw that are connecting the end plates and the pipe:

R_m ... tensile strength = 1000 [N/mm²]

R_e ... yield strength = 900 [N/mm²]

σ_{\max} ... maximum allowable stress = $0.9 \times R_e = 810$ [N/mm²]

E ... Young's Modulus = 2.1×10^5 [N/mm²]

d ... basic diameter = 20 [mm]

d_2 ... pitch circle diameter = 18.376 [mm]

d_3 ... core diameter = 16.933 [mm]

d_h ... bore diameter = 22 [mm]

l_k ... length of thread engagement = 50 [mm]

b ... length of screw = 90 [mm]

μ ... friction factor = 0.1 [-]

The settlement of the screw can be calculated as follows [17]:

$$\delta_s = \frac{1}{E} * \left(\frac{0.4 * d}{A_n} + \frac{l_1}{A_1} + \frac{l_2}{A_2} + \frac{0.5 * d}{A_3} + \frac{0.4 * d}{A_n} \right)$$

(Eq. 14)

Wherein:

$$A_n = A_1 = \pi * \frac{d^2}{4}$$

$$A_2 = A_3 = \pi * \frac{d_2^2}{4}$$

$l_1 = l - b = 0$ and $l_2 = l_k - l_1$

$\delta_s = 1.759 \times 10^{-6}$ mm/N

The settlement of the part where the screw is placed can be calculated as follows [17]:

$$\delta_t = \frac{l_k}{A_{sub} * E}$$

(Eq. 15)

Wherein:

A_{sub} ... substitutional cross-section [mm²]

$$A_{sub} = \frac{\pi}{4} * (d_w^2 - d_h^2) + \frac{\pi}{8} * d_w * (D_A - d_w) * [(x + 1)^2 - 1]$$

(Eq. 16)

Wherein:

$$x = \sqrt[3]{\frac{l_k * d_w}{D_A^2}}$$

(Eq. 17)

With:

d_h ... bore diameter = 22 [mm]

d_w ... diameter of screw head = 27.7 [mm]

D_A ... affected diameter = 40 [mm]

Resulting in $\delta_t = 0.597 \times 10^{-6}$ mm/N

Now the minimum assembly preload force (FVM_{min}) has to be calculated [18]:

$$FVM_{min} = FK_{req} + FZ + (1 - n * \varphi_k) * FA$$

(Eq. 18)

Wherein:

FK_{req} ... required pressing force [N]

FZ ... setting force [N]

n ... statistical table value [-]

φ_k ... setting factor [-]

FA ... force on screw [N]

The required pressing force (FK_{req}) is dictated by the sealing. For an o-ring with shore A 95 hardness and 5.3mm cord thickness, the recommended pressing is approximately 1300N [19].

FZ is calculated by [20]:

$$FZ = \frac{f_z}{\delta_s + \delta_t}$$

(Eq. 19)

Wherein:

$$f_z = 3.29 * \left(\frac{l_k}{d}\right)^{0.34}$$

(Eq. 20)

$$FZ = 1505.8N$$

n is a table value, for average 0.5 is taken.

$$\varphi k = \frac{\delta_t}{\delta_s + \delta_t} = 0.25$$

(Eq. 21)

FA is calculated from the force that is exerted on a screw by the internal pressure that is applied on the test bed.

The inner pressure p_i is 700bar (70N/mm²). The ID of the pipe is 83mm, so the area on that the pressure acts on the end plate is 5412mm². This results (F=p*A) in a total force of 378743N, having 8 screws on each side, the applied force per screw (FA) is 47343N.

Inserting the results in the equation above, the minimum assembly preload force is 44676N.

The settlement of the screw and the part are calculated:

$$f_{SV} = \delta_s * FVM = 76.5\mu m$$

(Eq. 22)

$$f_{TV} = \delta_t * FVM = 25.9\mu m$$

(Eq. 23)

From that point on a graphical solution is used – the stress triangular method: The settings in μm are plotted vs. the preload force in N and then the applied force per screw is drawn in the graph to get the static force on a screw (FS).

FS (roughly) = 55000N

$$\sigma = \frac{FS}{A_2} = 225N/mm^2$$

$$Safety = \frac{\sigma_{allowable}}{\sigma} = 3.6$$

The minimum torque (MA) when mounting the screws depending on the calculated preload force is approximated from the following equation [21]:

$$MA = 0.17 * FVM * d = 148Nm$$

(Eq. 24)

Above the static force on a screw was considered. This means if the screws can hold the end plate when pressure applied. But it is also important to verify that the threads in the plate can hold the screws when force from inside is applied.

The area of the thread that is holding the screw in the pipe can be calculated as shown below:

$$A_{thread} = n * d_2 * \pi * H_1 \quad (\text{Eq. 25})$$

Wherein for the used M20 screws:

$$n = \frac{l}{p} \quad (\text{Eq. 26})$$

With

l ... thread engagement = 40 [mm]

p ... pitch = 2.5 [mm]

H₁ ... middle pitch height = 1.534 [mm]

$$A_{thread} = 1416.92 \text{mm}^2 \quad (\text{Eq. 27})$$

$$\sigma = \frac{F_{total}}{A_{thread}} = \frac{p_i * A_1 + FS}{A_{thread}}$$

The maximum allowable stress σ_{max} for an E470 pipe is 470*0.9N/mm².

$$Safety = \frac{\sigma_{max}}{\sigma} = 8.5$$

Threads of Screws and Connectors in the End Plates

For the M6 screw (ventilation bore) the needed input values are [22]:

d₂ = 5.350mm

l = 16mm (40mm were planned but only 16mm could be manufactured)

p = 1mm

H₁ = 0.613mm

dk/2 = 3.9 (calculated from the equation below [24])

d₃ = 4.773mm

A₁ ... nominal area = 20.1mm²

R_e for a V320 plate with a diameter of 200mm (before manufacturing) is given on the Data Sheet by Böhler with 510N/mm² and therefore the max allowable σ_{max} is 90% of the 510N/mm².

$$\frac{d_k}{2} = 0.65 * d \quad (\text{Eq. 28})$$

At first the preload force of the screw FVM has to be calculated [modified from 24]. Therefore a torque (MA) of 40Nm for the M6 screw is assumed.

$$FVM = \frac{Ma}{0.159 * p + \mu_{total} * (0.577 * d_2 + \frac{d_k}{2})} \quad (\text{Eq. 29})$$

With an assumed μ_{total} of about 0.15 [24] FVM is 40.103N.

The force on the M6 screw FS caused by the inner pressure is $\pi * A_1 = 1978.9\text{N}$.

Therefore the total force on the thread is

$$F_{total} = FVM + FS = 2019\text{N}$$

The area of the thread is calculated by the equation given already above.

$$\sigma = \frac{F_{total}}{A_{tread}}$$

$$Safety = \frac{\sigma_{max}}{\sigma} = 37$$

The same procedure is done for the M16 thread (oil inlet/outlet) in the same end plate having the following properties [22]:

$$d_2 = 14.701\text{mm}$$

$$l = 40\text{mm}$$

$$p = 2\text{mm}$$

$$H_1 = 1.227\text{mm}$$

$$d_3 = 13.546\text{mm}$$

$$A_1 = 157\text{mm}^2$$

$$MA \text{ (assumed)} = 60\text{Nm}$$

$$Safety = 32$$

Also the threads of the G1/4in connectors (pressure gage and hydraulic hand pump) in the same end plate and in the modified nut having the following properties [22] are verified:

$$\text{OD thread min.} = 12.907\text{mm}$$

$$\text{OD thread max.} = 13.157\text{mm}$$

$$\text{ID thread min.} = 11.445\text{mm}$$

ID thread max. = 11.890mm

MA (assumed) = 40Nm

l = 6mm

$d_2 = 12.30\text{mm}$

$d_a = 13\text{mm}$

$d_3 = 14\text{mm}$

$\mu_{total} = 0.14$

φ ... pitch angle = 1.96°

A_1 (calculated) = 154mm²

Like for the M6, FVM is first calculated but this time the formula is slightly different [25]:

$$FVM = \frac{Ma}{0.5 * d_2 * [\mu_{total} + (1 + \frac{d_a + d_3}{2 * d_2}) + \tan\varphi]}$$

(Eq. 30)

From that point on the procedure is the same for A_{thread} and for the stresses.

For the G1/4in bore in the end plate with a diameter of 193mm (R_e for that diameter V320 is 510N/mm²) the safety is 1.34.

And for the G1/4in bore in the modified nut with a diameter of 80mm (R_e for that diameter is 635N/mm²) the safety is 1.67.

O-Ring Selection and O-Ring Groove

As mentioned before, polyurethane was selected as material for the o-rings. The dimensions, especially the cord thickness – that is linked to the OD and the o-ring material (hardness) – were selected according to manufacturer recommendation. The dimensions were set to 95mmID and 5.3mm thickness.

The shape and the dimensions of the groove are of vital importance to the tightness of the o-ring. As suggested by o-ring manufactures [26, 27] the groove was designed (incl. tolerances and surface roughness) according the sketch below:

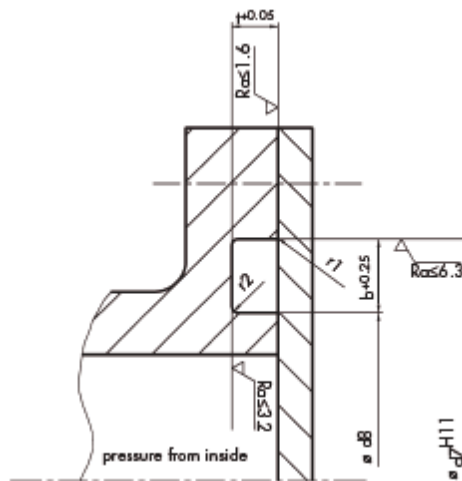

Figure 17: Groove Design for Axial Cover under Inner Pressure [26]

- d7...105.6mm (+0/-0.5mm)
- b...7.2mm (for 5.3 ring thickness)
- t...4.2mm (for 5.3 ring thickness)
- r1...0.2mm
- r2...0.6mm

For sealing against inner pressure (as it is the case here) the OD of the wall of the groove should be equal or slightly smaller than the ring OD. This ensures that the o-ring is in contact with the outer groove wall and by that in compression (so o-ring OD should be up to 3% larger than groove) [26].

Manufacturing and Construction

Pipe and end plates as well as the modified nut were turned at the lathe. The pin, internal and external seal rings were manufactured on a CNC lathe.

The modified nut as well as the pin were mangese phosphated to protect the threads (corrosion...).

Sealing Assembly

The modified nut is made from V320 (42CrMo(S)4+QT according EN10083, EN10060) round bar steel. In the original design the nut is from E355 because it has to be welded on the liner tube there. In that case here no welding is necessary but the hydraulic pump is directly connected. The focus of the testing is on the metal rings. Therefore using a higher grade material for the nut is possible. It is beneficial using V320 instead because this means less deformation of the closed end of the modified nut and a stronger thread.

The pin as well as the metal rings (internal and external ring) are made from the same V320.

At first it was thought to heat treat the metal rings by plasma nitriding to increase hardness of the surfaces but it turned out that the thickness of the rings was increased. Also the steepness is randomly altered in a way that the rings do not fit any more and would never create a hydraulic seal. Therefore no heat treatment should be applied because the changes in shape are rather unpredictable for such a thin part. Also testing the heat treatment at a sample ring might not display in how far the subsequent rings for manufacturing will be pulled out of shape because these changes also depend on smallest differences in the metallurgy of the base material.

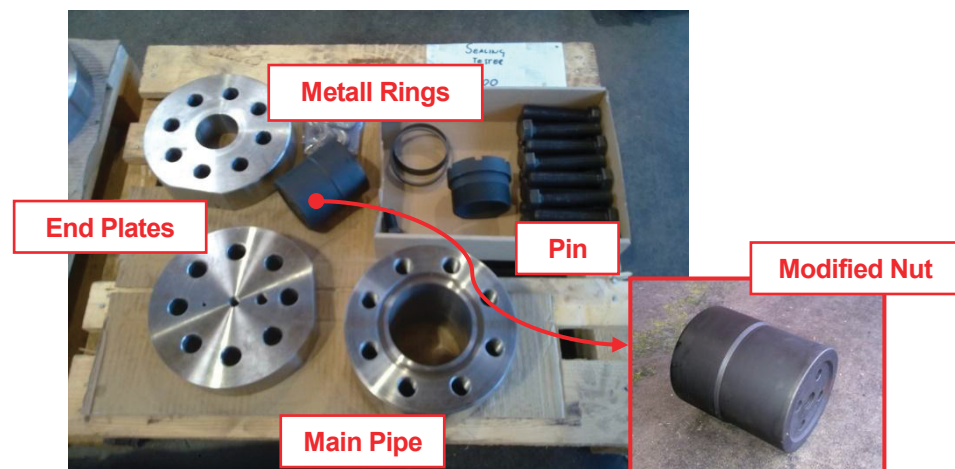

Figure 18: Manufactured Components for the Test Bed (200)

Liner & Sealing Tester

Requirements and Features

After having verified with the Sealing-Only Tester, which is described before that the metal sealing rings are working, the behavior of the whole liner tube should be tested too. In the smaller testing assembly the nut at the pin-end of the liner was modified. In contradictory to that the test cell now should allow to test standard pin, metal rings as well as a standard nut which is welded on a shorter inner liner tube. This liner tube is placed inside a heavy-walled pipe so that – like in the original design – an annular volume is created. This should be used to test the performance of different filler materials. Also the upset geometry as well as the geometry of the modified tool joints (where the liner is seated) should be simulated. To sum up the test bed to design should serve for two functions: on the one hand the test cell should allow ensuring the tightness of the nut at the pin-end of the inner liner having two metal rings as sealing elements and, as second function, the liner tube itself should be pressure tested together with the selected filler materials. Here not only the nut should be the original design, also the inner liner tube as well as the annulus should have the same dimensions as in reality.

Basic Idea and Function

To best fulfil the requirements mentioned above, it was decided to build in fact a model of the inner shape of a 5in, 19.5lb/ft, G105 drillpipe but without the NC50 connectors. Having the same diameters as the original makes it possible to place the original size liner tube as well as the original sealing assembly inside. Also the internal upset geometry of the tool joints is reconstructed. Because a drillpipe would have roughly nine meters, what would make the test bed costly and difficult to handle, the length was reduced, so that the liner tube length is approximately ten times its diameter. Concerning the upsets at the tool joints the pitches and the diameters are the same as in reality, only the lengths where there is no change in diameter have been reduced. These are valid simplifications since for pressure testing the lengths are not of great importance.

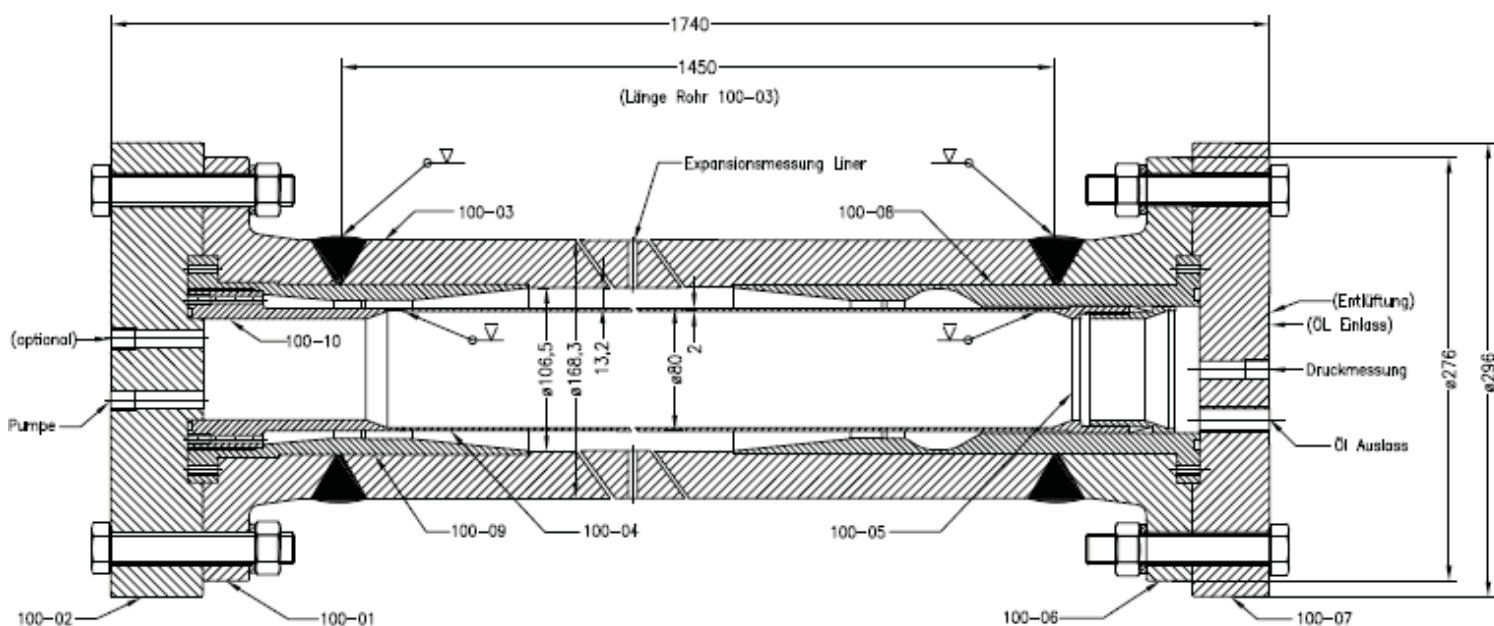

Figure 19: Main Inner Pressure Test Bed

The test bed – that is shown in the sketch above – consist in fact of ten major components: the main pipe (100-03) with the two main flanges (100-01,06) welded on, two end plates (100-02,07), two hollow cylinders (100-08,09) that are simulating the upset geometry and the tool joints, the inner liner pipe (100-04), the sealing assembly (100-05) and one nut (100-09) for liner tube fixation. The function and the parts are now described:

Main Pipe with Flanges

The main pipe simulates the drillpipe. Therefore it is important that this pipe has the same inner diameter as the original 5in, 19.5lb/ft pipe. As stated in API Specification for Rotary Drill Stem Elements [28], the inside diameter of a drillpipe is governed by the tolerance of the outside diameter (what is in the range between +1% and -0.5% for drillpipes larger than 4.5in) and the weight tolerance for the wall thickness. The OD of the main pipe does not influence the test at all. It is only important that the inside of the drillpipe is represented in the test bed using the actual diameter. This gives the opportunity to use normal E355 steel for the main pipe. To achieve the same strength as the G105 drillpipe (or at least to stand the test pressure of 700bar) the OD of the main pipe is larger than the original drillpipe OD. But E355 steel has the major advantage that it can be easily welded without needing larger heat treatments. When using higher grade steels as material for the pipe (or flanges), heat treatments before (preliminary annealing) and especially after (stress relief treatment/ stress free annealing) welding would have been necessary. Considering the larger dimension as well as the weight of the main pipe, it is obvious that high costs would have been involved with that.

The main pipe should just simulate a short part of a real drillpipe (the length of the middle section is reduced where there is no change in shape and diameter), without having the NC50 male and female connectors. Instead of the connectors, flanges are welded on the pipe ends in order to be able to create a closed pressure cell. These flanges are again made from E355 steel in order to have no welding problems. The flanges were custom made from a block of round steel. The design of the flanges is optimized for standing the axial force that is exerted on the closed test cell by the inner pressure.

The welding seam between the flanges and the main pipe is of huge importance. It must be ensured that this seam also hold the inner pressure of 700bar.

In the middle section of the main pipe eight bores are drilled. In these holes studs can be inserted which contact the liner tube at their lower end. At their upper end the studs are kept in position by being connected with a wire. An expansion of the liner tube due to inner pressure would press the studs a little bit more outwards. This movement with increasing pressure applied could be measured and by that a possible radial expansion of the inner liner tube can be monitored and investigated. One important consideration is that these studs should on the one hand move easily and without giving too much resistant to the inner tube but on the other hand the gap between stud and bore should not be too large so that the fine grained filler material is not lost. Therefore studs having a positive tolerance were chosen. These studs were polished until a perfect fit was achieved. NB: The same bores could be used to contact strain gages.



Figure 20: Main Pipe with Flanges

End Plates

The two flanges at each side are closed by circular shaped end plates that are slightly larger in diameter as the flanges. For connecting end plates and flanges 8 M20 10.9 high strength screws are used on each side. Due to the fact that there is no welding on the end plates, the plates are made from V320 steel (42CrMo(S)4+QT according EN10083, EN10060). This is important because in the end plates there are all connectors placed. On the left end plate (where the box-end of the drillpipe would be) there is the G1/4in connection for the hydraulic hand pump. The outer surface is polished in that area to reduce surface roughness in order to create a good seal where the pump is installed.

On the right end plate (where the pin-end of the drillpipe would be) there is in the center again a G1/4in thread for the pressure gauge. For the first tests the internal pressure is monitored by using an analog manometer. But a second G1/4in thread is planned at the box-end in order to mount a pressure sensor there to be able to digital record the pressure exerted on the inner liner assembly. This thread is only planned, but not yet cut in order not to have sealing problems or problems with the tightness of the test cell when plugging that thread.

On the same side as the manometer are also the openings for filling the interior of the test bed with hydraulic oil. One upper M16 opening is used for filling the cell where else the lower M16 opening is used as outlet for the oil. The smaller M6 bore is just for ventilation. It is of great importance that there is no trapped air inside before pressure is applied. The position of these holes is rather easy to find: When the end plate is in the right position, the inlet as well as the ventilation outlet should be at the highest possible spot. The outlet for the oil should be at the lowest spot. This arrangement makes it possible to fill and discharge the test bed in a slanted position. But still – in case a forklift is available – the test bed should be filled with hydraulic oil in a vertical position. The inlet and the outlet can be plugged by the corresponding M16 10.9 screws with the maximum length of 40mm. Also the bore for venting can be plugged by a M6 screw of the same strength and length. No standard lock screws were used because for that required pressure rating none were available. Therefore 10.9 screws with the greatest possible length were used instead – as customized lock screw so to say. The high strength as well as the length is important to hold the screws in the threads of the end plate (also the material of the end plate plays an important role – therefore V320 was chosen).

On both sides of the end plates are sealing surfaces. On the one side because of the connectors (pump and manometer) and the lock screws and on the other side because of the rubber o-rings to seal between the flanges and the end plates. The thickness of the end plates is chosen to stand the 700bar without too large deformation to avoid opening of a joint and leakage at the o-ring. The strength at the weakest point has to be sufficient therefore.

The end plate at the box-side has a larger groove at the inner surface. In that groove the fixation nut of the liner is placed. This groove also serves for centering the end plate at that side. Also the second end plate (at the pin-side) has a circular lowering for centering the end plate on the cylindrical insert there.

Cylindrical Inserts

The target also was to simulate the internal upset and the inner tool joint geometry. Due to the fact that manufacturing these complicated shapes in the big main pipe would be demanding, it was chosen to insert hollow cylinders at the ends of the main pipe. These cylindrical inserts can be easily manufactured from E470 (HSB) steel pipes to simulate the inner upset geometry of the pin- and the box-end of the original pipe. Therefore all diameters as well as all flank inclinations are full size, only the sections where there is no change in inner diameter have been reduced. For placing them inside the pipe, the main pipe has a slightly enlarged inner diameter at both ends. These inserts can be exchanged to modify the inner geometry.

The insert on the right side (that simulates the pin-end of the drillpipe) has a groove in the plain end where a polyurethane o-ring (same material and size as in the short tester) can be placed.

The insert on the left side (that simulates the box-end of the drillpipe) has an internal thread at the end. Here the liner fixation nut is screwed in. Many different ways of fastening the inner liner tube on the box-side of the test cell were discussed during the design process (mounting sets, welding...). But the presented solution by having a thread inside the insert offers two main advantages: On the one hand the annular volume is perfectly sealed and on the other hand this perfectly matches reality where also the nut of the liner tube is screwed into the tool joint of the box.

Both cylindrical inserts offer at the end an enlarged outer diameter. These rings are used to place the cylinders in the both flanges and are ensuring that not the flange surface but the plain ends of the inserts (or liner fixation nut) where the sealing elements are placed are in contact with the end plates. This creates a gap between the flange and the end plate. When setting and defining the tolerances for manufacturing it is of major importance to always check that this gap still exists also for the “worst case”.

At the plain end of the insert on the left side again, four M6 borings are placed there. These threads serve for two reasons: at first they can be used holding the insert in place when the fixation nut (and by that the liner) is screwed in, and second after testing the liner can be pulled out of the main pipe there by screwing in four longer sized M6 ring screws.

Liner Tube with Fixation Nut

The liner tube is made from the same material as the original and having also the same OD and the same wall thickness (E235, OD 80 mm, ID 76 mm, for more information on that see chapter “General Aspects – The Liner Assembly Design”). The length of the liner (1360mm) was determined to more or less center the sealing assembly in the middle of the end section of the cylindrical insert simulating the pin-end. It must be mentioned that for the original drillpipe two inner tubes must be welded together. Because of the shorter length, this is not the case for the test bed. So a failure of the liner tube due to a possible break down of the welding seam between the two liner tube parts cannot be excluded.

The fixation nut that is welded on the box-end of the liner is not to be tested in that pressure cell, but nevertheless it has almost the same dimensions and shape as the original nut but is slightly modified: There are no inner threads for mounting the protective bushing. At the plain end there is a groove placed for installing again a polyurethane sealing ring there (same material as before, but smaller in size). The nut offers four through holes with M6 threads. These openings are used for filling the annular volume with the ceramic beads. The openings are somewhat different from the original fill ports. In the original design M8 borings are used with a thread depth of 15mm. Therefore a filling test (as described in the chapter on the filler material) was carried out. It turned out that with the calculated annular volume of the test bed, what is 5.088l considering the chosen liner tube length, the filling in a vertical position would take 8.5 minutes. But these M6 openings – that are plugged during testing by the corresponding allen screws – are not for filling only, also the tool for screwing the liner in the cylindrical insert can be mounted by using M6 10.9 screws. The nut is only screwed-in to that point where its plain end, where the sealing o-ring is placed, is slightly in front of the plain end of the cylindrical insert in order to ensure a good sealing at the o-ring there. In that way the cylindrical insert will not be exposed to the inner pressure.

Sealing Assembly

The metal sealing assembly including nut (that is welded on the pin-end of liner tube), internal and external metal seal ring and pin is absolutely the same as in the original liner layout. A description of the material and the design can be found in the chapter “General Aspects – The Liner Assembly Design”.

To sum up: The inner pressure test bed is in fact a model of a 5in, 19.5lb/ft, G105 drillpipe (without connectors). Due to this and having also exchangeable inserts for the upsets the test bed can also be used later on as inner pressure test cell for various purposes.

Mechanical Design and Layout

The mechanical layout is carried out to achieve building a test cell that can stand an inner pressure of 700bar. Therefore the following considerations and material verifications were made:

Main Pipe Dimensions and Wall Thickness

To ensure good weldability E355 was chosen as material for the main pipe. The downside is that a rather large wall thickness is needed (and by that the test bed gets heavy). When ordering such a seamless, normalized steel pipe (S355J2H/ E355+N according to EN10220/10210-1/10297-1) it is important to account for a 12.5% tolerance of the ID.

In a first step the required wall thickness for E355 (R_e of 355N/mm²) was figured out. A wall thickness of 30mm turned out to be sufficient at the necessary ID.

The length of the pipe was set to 1450mm. To select the pipe, the ID should be in the range of the ID of the original drillpipe what is about 108.62mm. From the available pipes that pipe was selected that is first as close as possible to the ID of the drillpipe (accounting for the tolerances for the original drillpipe and for the steel pipe) and second has a wall thickness of at least 30mm. Therefore the following dimensions were selected: Nominal ID of 108.3mm (delivered slightly larger but still in range and 114mm as largest ID after manufacturing) and OD of 168.3mm.

Using the excel spreadsheet (same as for the smaller test bed as well) the maximum equivalent stress in the drillpipe wall (that is at the inner circumferential) could be calculated:

$$\sigma_v = 209.8N/mm^2$$

The maximum allowable stress is 90% of the yield strength of the E355 (what is 355 times 0.9).

$$\sigma_{max} = 319.5N/mm^2$$

The safety (S) is now given by:

$$S = \frac{\sigma_{max}}{\sigma_v} = 1.52$$

Screws

That M20 screws with strength of 10.9 can stand 700bar inner pressure in a cell of roughly that dimensions was already proven in a rather scientific way for the smaller test bed before. Therefore it is only necessary here to make a quick validation with the following considerations:

$$Safety = \frac{Allowable\ Stress}{Applied\ Stress}$$

The allowable stress for a 10.9 screw is 90% of the strength of 900N/mm² what is 810N/mm².

The applied stress (σ) can be quickly estimated from:

$$\sigma = \frac{\text{Applied Force}}{\text{Effective Area}}$$

As there are eight screws on each side connecting end plate and flange, the force on each screw (FS) is given by the force that is exerted by the inner pressure (70MPa) on the end plate (having a diameter of 80mm that is exposed to the inner pressure) divided by eight:

$$FS = \frac{70 * (40^2 * \pi)}{8} = 43983N$$

The effective area (As; considered core diameter) for a M20 screw is: 225mm² [29].

The applied tension therefore is:

$$\sigma_{\text{applied}} = \frac{FS}{As} = 196N/mm^2$$

So the safety is about 4 (without preloading).

Verification of the Threads

The connectors for the hydraulic pump and the manometer (G1/4in threads) as well as for the oil inlet and outlet (M16, M6 threads) are the same like in the small tester. The end plates are again made from V320. Therefore the safety is also about the same. The only thing that changed is the size of the end plates and by that the yield strength of the V320 changes a bit. The yield strength for a V320 having a diameter larger than 250mm is between 450-500N/mm². As average 480N/mm² was considered what leads to a minimal safety for the G1/4in threads in the end plate of 1.3 (for calculations see the corresponding chapter for the layout of the Sealing-Only Tester).

End Plates

The end plates are made from V320 round bar steel. The validation was done at their thinnest (weakest) spot according to equation 12 on page 35.

For the end plate at the box-end:

$$P = 700\text{bar}$$

$$b = 33\text{mm}$$

$$h = 50\text{mm}$$

$$R = 148\text{mm}$$

$$E = 2.1 \times 10^5 \text{N/mm}^2$$

Giving a deformation under load applied of: 0.099mm

For the end plate at the pin-end:

$$P = 700\text{bar}$$

$$b = 41.5\text{mm}$$

$$h = 45\text{mm}$$

$$R = 148\text{mm}$$

$$E = 2.1 \times 10^5 \text{N/mm}^2$$

Giving a deformation under load applied of: 0.589mm

Weld design

The welding seam between flanges and main pipe is very critical because an inner pressure of 700bar should be handled. Therefore the pipe as well as the flanges are made from E355 to ensure good weldability.

Validation of the welding seam:

The welding seam between the flanges and the main pipe can be simplified by the following sketch:

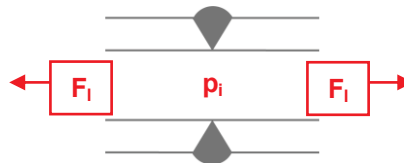

Figure 21: Sketch of Welding Seam

At first the required thickness (t) of the circumferential welding seam is calculated [modified from 30]:

$$t = \frac{OD * p_i}{2 * \frac{R_e}{S} * v + p_i}$$

(Eq. 31)

Wherein with:

R_e ... here 355N/mm² for E355

v ... 0.85 (for welding seam not inspected)

S ... 1.5 as safety factor

OD ... Outer Diameter (of 168.3mm)

p_i ... Inner Pressure (of 700bar = 70N/mm²)

This results in a required thickness of 25mm. So the 28mm in the design are by far sufficient.

Now the safety of the welding seam can be calculated according the following considerations [31]:

The welding seam is mainly subjected to axial force (tension because pressurized pipe with closed end plates can be seen as chamber) and lateral force.

The axial stress (σ_a) is calculated by:

$$\sigma_a = \frac{\text{axial Force}}{\text{affected Area}}$$

The axial force (F_a) is the inner pressure times the area on that the inner pressure acts. So it is 70MPa on a circular area with a diameter of about 80mm (on end plate) what leads to 378743N.

The affected Area (A_N) for the main pipe (OD 168.3. ID 108.3) can be calculated:

$$A_N = \frac{\pi}{4} * (OD^2 - ID^2) = 13035mm^2$$

Inserting F_a and A_N above, the axial tension is 29N/mm².

The lateral stress is calculated by:

$$\tau = \frac{\text{lateral Force}}{\text{affected Area}}$$

The lateral Force (F_l) is calculated from the inner pressure (70MPa) acting on the seam area. This area is the circumferential of the inner tube having a diameter of 76mm times the length of the from the welding process influenced region what is approximated with 30mm (thickness is equal width). Therefore F_l is 957600N.

The affected area (A_N) is again 13035mm².

Therefore τ is 74N/mm².

The maximum lateral force is two times the mean force what is 148N/mm².

Now calculating the equivalent stress (σ_v):

$$\sigma_v = \frac{\sigma_a}{2} + \sqrt{\left(\frac{\sigma_a}{2}\right)^2 + \tau^2} = 89.9N/mm^2$$

(Eq. 32)

The safety factor is again the maximum allowable stress divided by the equivalent stress.

At first the maximum allowable stress has to be calculated:

$$\sigma_{max} = v_1 * v_2 * \frac{R_e}{S}$$

(Eq. 33)

Wherein:

v_1 ... type of welding seam

v_2 ... quality factor

R_e ... yield strength (assumes same as base material)

S ... additional safety for material

With

v ... 1 for (circumferential) butt weld; tension applied [30]

v_1 ... 0.8 for welder certified but seam not checked [30]

R_e ... 355N/mm²

S ... 1 (not necessary in that case)

$$\sigma_{max} = 284N/mm^2$$

So the safety of the welding seam is: 3.2

O-Ring Selection

The o-ring selection as well as the groove dimensions follow the same principle as for the Sealing-Only Tester (see [26] as well as corresponding chapters in the thesis).

Again polyurethane 95 shore A o-rings are used with the following dimensions:

On the box-side in the groove of the fixation-nut: 73mm ID x 3.55mm cord thickness

On the pin-side in the groove of the cylindrical insert: 95mm ID x 5.3mm cord thickness

Manufacturing and Construction

The flanges were first manufactured to their basic shape having only the rough outer dimensions and the bore but not their final inner shape. These prepared flanges were welded on the main pipe. The main pipe – including the flanges now – was clamped in a large size lathe and the final inner shape of the flanges and the pipe was created.

For welding the flanges on the pipe electric arc welding for construction steels (electrode welding) was selected on recommendation of a welding specialist who was also in charge of the execution of the welding afterwards. The following stick electrode (welding consumable) was used: FOX EV50 by Böhler Welding – welding rod for steel lower or equal 355N/mm² yield strength.

The liner fixation nut, the nut of the sealing group as well as the pin were manganese phosphate coated in order to protect the threads against corrosion and mechanical forces. The fixation nut as well as the nut of the sealing assembly were welded on the liner tube.

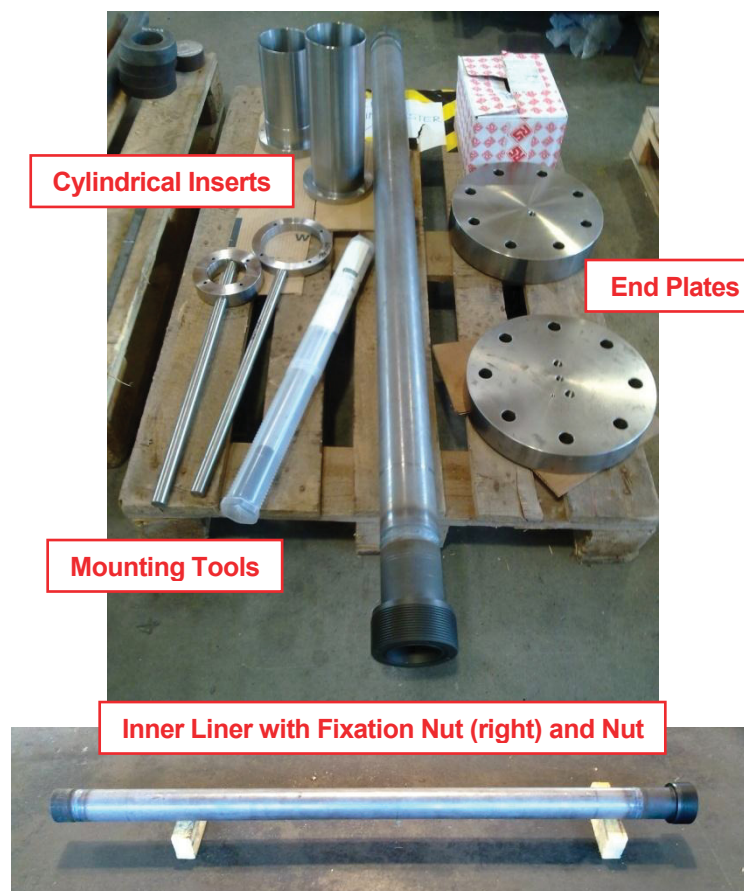

Figure 22: Manufactured Components for the Test Bed (100)

Protective Bushing Tester 1

The protective bushing has two sealing ends: The first is the nose of the bushing that is engaged with (pressed against) the pin of the subsequent drillpipe when two pipes are connected in one stand, and the second sealing is the thread where the protective bushing is fixed in the nut of the liner tube. Because there are two spots where leakage can occur, two test cells were built to investigate each one on its own.

Requirements and Features

With the first tester the sealing capacity at the nose of the protective bushing that is seated in the pin-end of the subsequent drillpipe should be checked. The shape of the nose is a crucial design feature of the liner assembly. This shape is determining the contact pressure, the load distribution as well as the distance of the movement of the nose inside the pin-end when making connection. This all is of major importance to the compression of the protective bushing at the nose end what is ensuring the tightness of the sealing there. Therefore it should be possible to test several nose designs as well as several pin-end shapes. Also the contact pressure and the movement of the nose of the bushing inside the pin should be adjustable. Again an inner pressure of 700bar should be applied.

Basic Idea and Function

Therefore the test bed that is shown below consists of the following main parts:

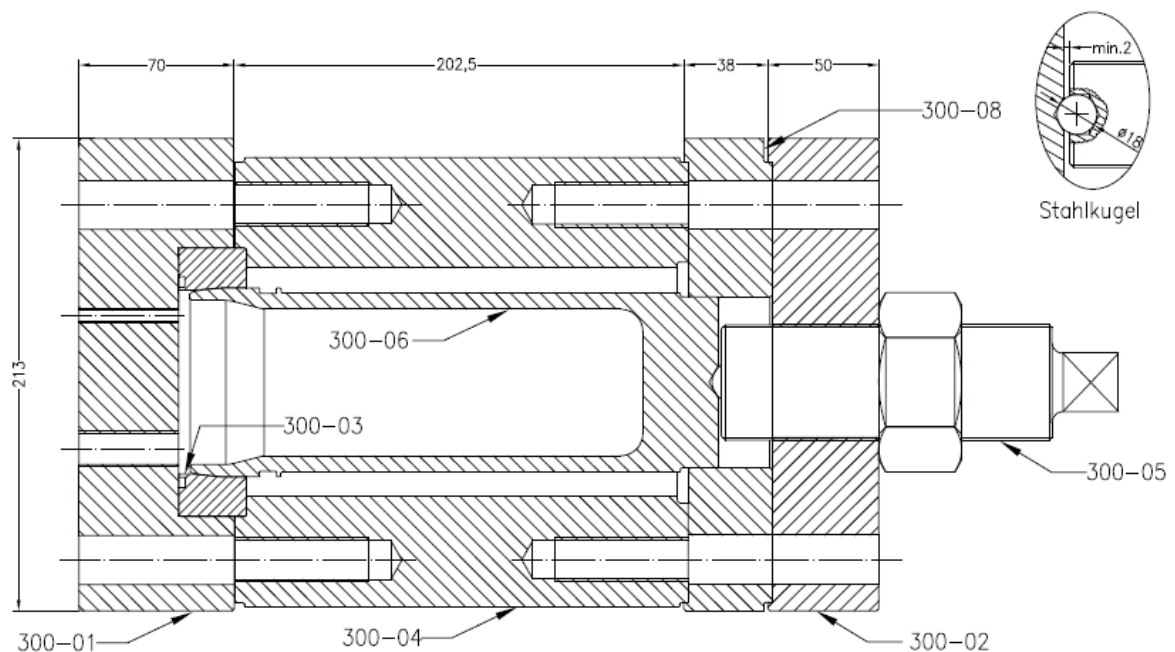

Figure 23: Protective Bushing Tester 1

300-01, 300-02 ... end plates; 300-03 ... pin insert; 300-04 ... main pipe; 300-05 ... motion screw; 300-06 ... protective bushing; 300-08 ... middle plate

Main Pipe

The main part is again a steel pipe for containing the pressure. Because no flanges are welded on, this pipe is made from E470 what has higher yield strength and by that a smaller wall thickness can be used. Upsets at the pipe ends allow to centralize the pin insert as well as the right end plate.

End Plates

To create a pressure chamber the main pipe is closed by two end plates made from V320 again to hold the connectors and screws. In this case all threads and all bores have to be in the left end plate because this is the only access to the interior of the protective bushing. There are two G1/4in threads for the pump and the manometer, one M16 thread for oil inlet/outlet and one M6 hole for ventilation. As this area is used for sealing it is polished to a surface roughness of 1.6. The right end plate has in its center a M52x2 internal thread to engage the motion screw there.

Pin Insert

To be capable to exchange the shape of the pin-end, the pin-end of the subsequent pipe is simulated by a ring that is inserted in the left end plate. It makes sense to not cut the shape of the pin directly in the end plate because several tries might be necessary until a seal is created. This pin insert is held in place by eight M6 screws. Only the strength 8.8 is necessary because the pin insert is pressed between the main pipe and the end plate. So there is a gap between these two components. When setting the tolerances it is very important to ensure that this gap is still present also in the "worst case". The axial compression that is necessary to hold the insert against the 700bar inner pressure is created by the M20 10.9 screws that are connecting end plate and main pipe. For sealing a polyurethane o-ring again is mounted in the groove of the insert. The material is again heat treatable steel (V320).

Motion Screw

To be able to move the protective bushing versus the pin insert and to regulate the compression of the nose of the bushing a custom made M52x2 motion screw is used that can be precise adjusted because of its fine pitch. As material V320 is chosen. Also the end plate having the corresponding internal thread is made from V320. This ensures that the thread holds the high inner pressure. A steel ball with a diameter of 18mm and a hardness of 62 HRC is placed between the motion screw and the protective bushing. This should ensure that the protective bushing is not twisted when the motion screw is turned and axial force is applied. A customized nut is used to counterforce the screw.

Protective Bushing

The shape of the protective bushing made from V320 (material as described in the previous chapters) is the same as the original, but having a closed end where the external thread would be. This has the advantage of only one open end where unwanted leakage of the test bed can occur.

Middle Plate

The middle plate just has the function to center the protective bushing. Therefore it is made from S235JR only.

Mechanical Design and Layout

Main Pipe

No welding at the main pipe makes it possible to use E470 (HSB, material number 1.0536 according to standard EN10294-1) as material having a yield strength of 470N/mm². Due to the higher strength of the material and the fact that the ID does not play that important role for that test bed, selecting the pipe is not as complicated as for the test beds before. A quick calculation using the excel spreadsheet based on the equations 7, 8 and 9 (p. 33) again should verify if the pipe can stand the inner pressure. The input parameters are:

OD: 202.5mm

ID: 103mm

Max. allowable stress (90% of yield strength): 423N/mm²

Inner pressure: 700bar

External Pressure: 1bar

Results in a max. equivalent stress that is located at the inner pipe wall of: 139.8N/mm²

The safety now is 3, what is by far enough to also make slight inner diameter changes during manufacturing.

End Plates

Also the deformation of the left end plate (300-01) is calculated at its weakest point under pressure applied. Therefore equation 12 (p. 35) is used inserting the data given below. The right end plate (300-02) as well as the middle plate (300-08) are not directly subjected to inner pressure because of the closed end of the protective bushing.

Left end plate (300-01):

b = 41.5mm

R = 110mm

h = 45mm

E = 2.1x10⁵N/mm²

p = 70MPa

Results in a deformation of 0.524mm

Screws and Threads

Again M20 10.9 screws are used for connecting the end plates to the main pipe. As mentioned before, this type of screw can stand the 700bar inner pressure in a pressure cell of approximately the given dimensions. Nevertheless a quick calculation is made.

For the M20 in the end plate on the left side (300-01) the same procedure as for the M20 in the Sealing-Only Tester before is applied:

The area of the end plate where the pressure of 700bar acts on has a diameter of 83mm (inside diameter of the pin insert). This gives an axial force on the plate of 378743N, having eight screws the force on each screw is 47343N. For a M20 screw the effective cross-section is 225.2mm² and the maximum allowable stress is 810N/mm² (90% rule). Following this, the axial stress on each screw is 211N/mm², what means a safety of 3.8.

For the end plate on the right side (300-02) the force exerted on the motion screw has to be taken into account. This force can be calculated from the pressure inside (700bar) and the area of the closed end of the protective bushing (diameter of 66mm). This results in a force of 239484N that the motion screw must hold. This force also acts on the end plate (300-02), having again eight M20 10.9 screws. This leads to a stress of 133N/mm² per screw, what means a safety of 6.

The threads for connecting the pump and the manometer (G1/4in) as well as the M6 and M16 threads for the oil filling are again the same as for the Sealing-Only Tester (end plate is also of approximately same sized V320).

But the thread of the motion screw inside the right end plate has to be verified. Here it is just important that the M52x2 thread of the motion screw can hold the protective bushing in place that is subjected to the 700bar inner pressure.

The input data for a M52x2 (fine threaded) screw is:

L...50mm (nut to counterforce screw is not considered)

p...2mm

H₁...1.7321mm [32]

d₂...50.701mm [32]

The thread area is calculated as usual: 6897.3mm²

The force that the screw must hold can be seen from above: 239484N. This leads to a stress on the thread of 35N/mm².

The maximum allowable stress for round V320 with a diameter of 220mm is again 90% of the respective yield strength for that delivery bar size: 441N/mm² (yield strength for that size assumed to be 490N/mm², according to V320 Data Sheet provided by Böhler).

This gives us a safety of rather reassuring 14.

The motion screw is a fine threaded customized screw of larger size used to have a small axial movement for a rather large angle when turning. This makes calibration and monitoring of the pressing force as well as the axial movement of the protective bushing easier.

O-Ring Selection

There is only one polyurethane o-ring necessary to seal the pin insert in the end plate. The material, design of the groove and selection criteria are again the same like for the other test beds. Here the dimensions were set to 88mm ID x 3.55mm cord thickness.

Manufacturing and Construction

The motion screw as well as the end and middle plates were manufactured from round bar steel on a normal lathe in the workshop as well as the pipe. The difficult shape and the fine tolerances of the protective bushing and the pin insert made the use of a CNC machine necessary. The bushing needed to be made from round bar steel because of the closed end. The ring for the insert instead was cut from a plate. Both, protective bushing and pin insert are made from heat treatable V320 and therefore heat threatened (plasma nitriding) to achieve approximately the same hardness as for an original tool joint. These parts are additionally manganese phosphate coated.

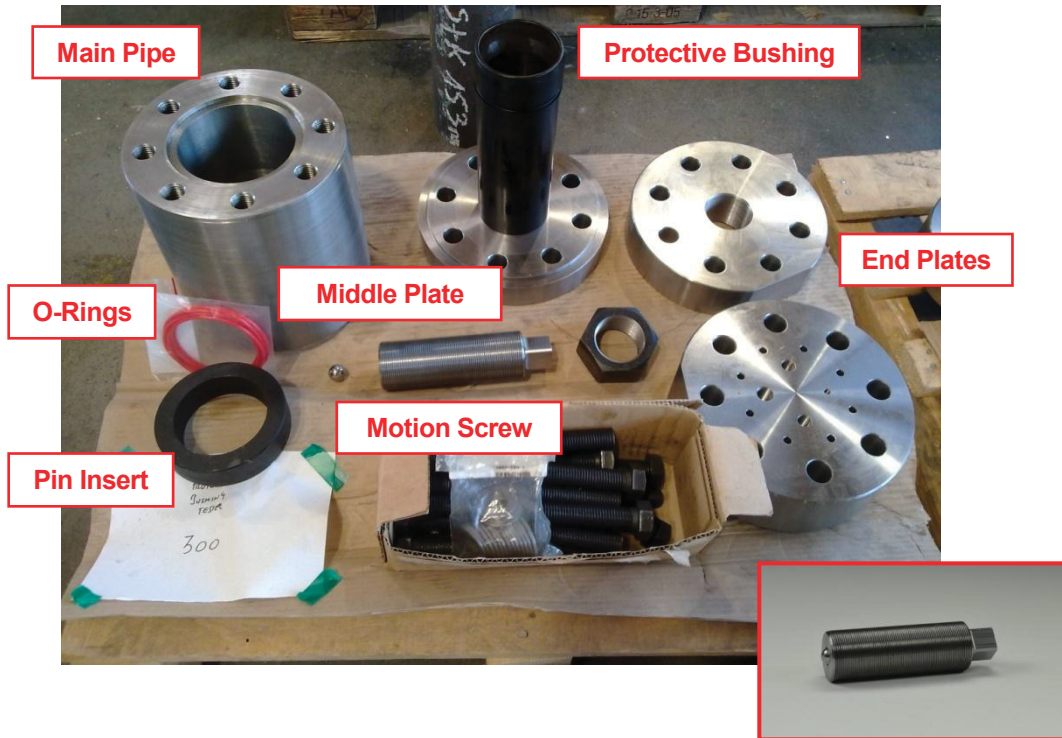

Figure 24: Manufactured Components of the Test Bed (300)

Protective Bushing Tester 2

Requirement and Features

Now also the threaded connection between protective bushing and the liner nut has to be pressure tested. There a nose is pressed against the corresponding part of the nut by using a M80x3 left-handed thread.

Basic Idea and Function

Because of saving costs it was chosen to use the same main pipe as for the Protective Bushing Tester 1. This is possible because here again the ID of the pipe does not play a major role and also a protective bushing is installed inside. It has just to contain the inner pressure (for safety and in case of severe failure).

The main parts can be seen from the drawing below:

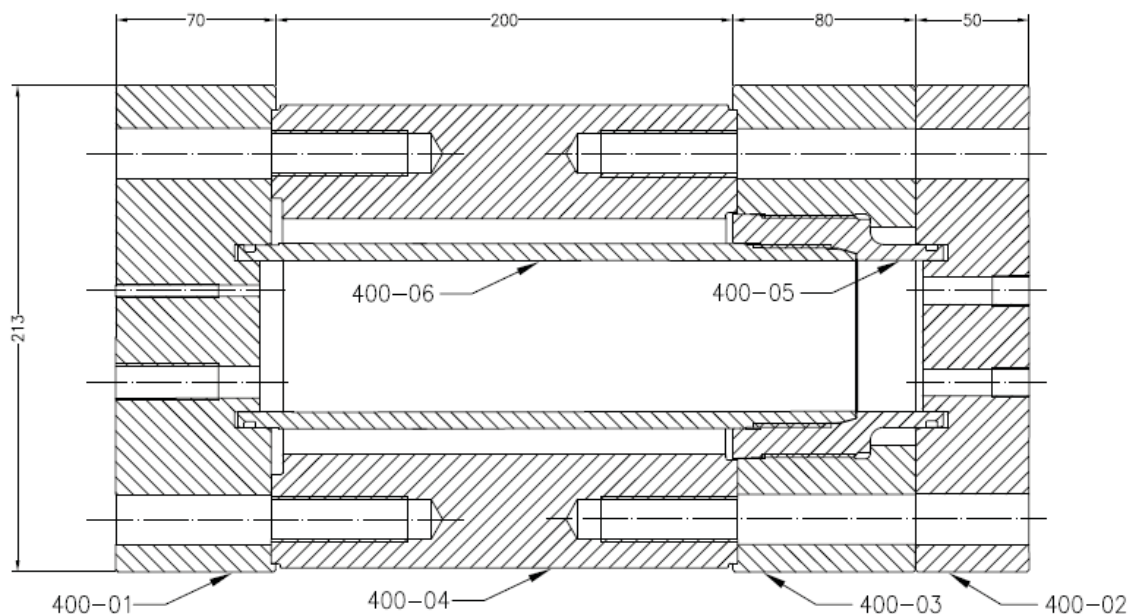

Figure 25: Protective Bushing Tester 2

400-01 and 400-02 ... end plates; 400-03 ... middle plate; 400-04 ... main pipe; 400-05 ... liner nut; 400-06 ... protective bushing

The principle of this test bed is the same as for the other test cells. Therefore also the main pipe and the end plates serve for the same duties as in the others. The parts that are new are:

Middle Plate

This middle plate can be seen as the tool joint in reality. Here the liner nut is fixated. This plate made from V320 (to have comparable strength to the tool joints) has a M106x3 left-hand inner thread in the center. This is the same (also same length) as in the original tool joints. There the liner nut can be placed. This thread is not cut into the main pipe in order to reuse the pipe and to easier make changes on the thread itself.

Liner Nut

The liner nut is the same as in reality having an outer thread (M106x3, left-hand) in order to be placed in the middle plate and an inner thread (M80x3, left-hand) to be engaged with the protective bushing. The shape of the sealing surfaces is the same as for the original. Only the length is slightly different. Also a radial groove is added to the right end in order to place an o-ring there to be seated in the corresponding groove of the end plate. The liner nut has no openings for filling like in the original and also the bores for using mounting tools are changed slightly. For the test bed three M6 threads are used giving the opportunity to use mounting tool as described in the chapter on the assembling procedure. The tool is a metal ring with three 7mm bores and a lever used to engage M6 10.9 screws with the corresponding M6 threads of the liner nut.

Protective Bushing

The protective bushing should be as close to reality as possible having all diameters the same as in the original. Therefore it has no closed end to avoid axial tension on the threads on the right side. The right side of the protective bushing is the same as the original having the M80x3 left-hand thread with the sealing nose. The nose at the other side of the bushing that is engaged with the pin-end of the subsequent pipe is not rebuilt because this has already been tested before. Instead of this nose there is a radial groove for placing an o-ring that is sealing in the corresponding groove of the end plate.

Mechanical Design and Layout

Main pipe, screws and threads are the same as in the Protective Bushing Tester 1. As well as the end plate thicknesses are comparable. In both test beds the protective bushing is pressurized and therefore the same diameter is subjected to the inner pressure. This gives always the same forces.

O-Ring Design

Only the o-ring design is different. To ensure that the protective bushing or the liner nut is not compressed or tensioned axially, like in the original drillpipe-liner design, the o-rings were placed in radial grooves at the ends of the inner components that are therefore placed in grooves in the end plates.

The concept is the same as for a piston packing but only loaded statically. The dimensions (as shown below [26]) are therefore given in the blueprints in the Appendix B. The following o-rings (same for each side to save costs for manufacturing) were selected because the rings should be mounted slightly tensioned.

O-rings: 73mm ID x 3.55mm cord thickness made from polyurethane 95 shore A.

The manufacturing tolerances in axial direction of the components (length of protective bushing...) were of major importance to perfectly place the o-rings in the grooves of the end plates.

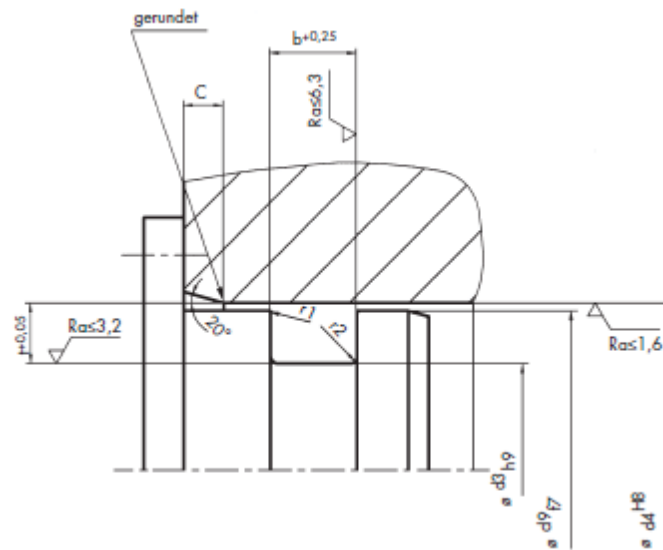

Figure 26: Groove Design for Piston Packing [26]

Manufacturing and Construction

Although of having a large inner bore the protective bushing is made from V320 round bar steel (equal 42CRMO(S)4+QT/ 1.7225; EN10083, EN10060) in order to have the high strength that is needed and to be able to harden the component by heat treatment. The liner nut instead is made from E355 steel pipe (EN 10220/ 10210-1/10297-1). Both parts were manganese phosphated.

The end plates and middle the plate does not only offer centralizing lugs, also the bottom is flattened to provide a good stand.

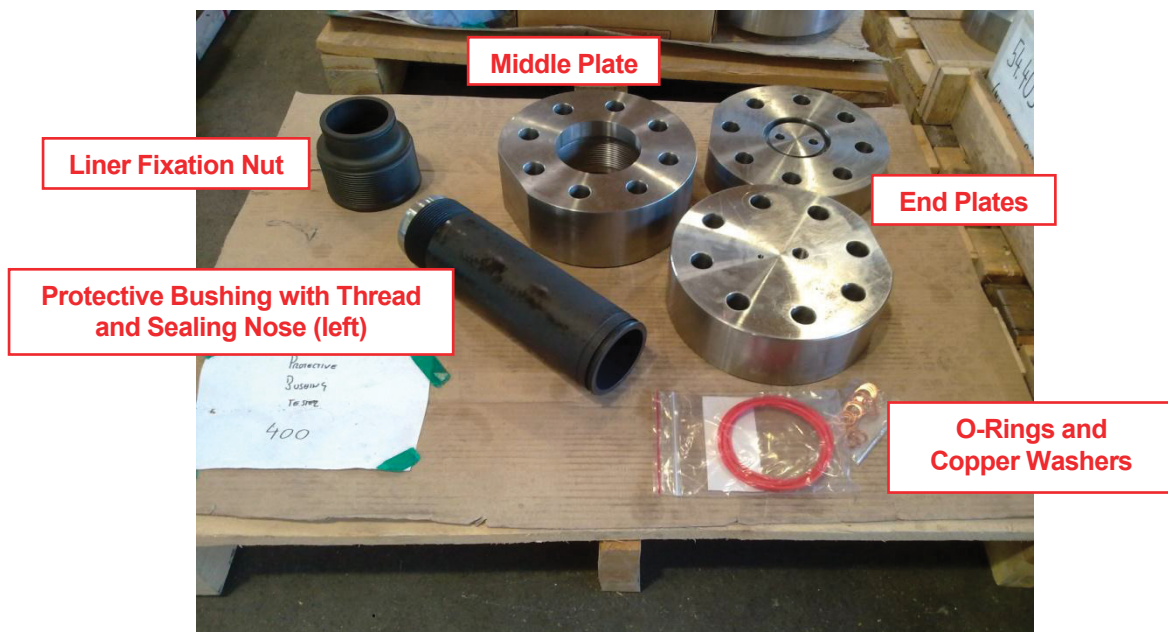

Figure 27: Manufactured Components of the Test Bed (400)

Hoisting and Safety Equipment

Bench with Cover

A wooden table was constructed to place the test beds in a comfortable working height. This is necessary when assembling and disassembling the test cells. Also filling with hydraulic oil is much easier. When getting the oil or the filler material out again, the test cells only have to be tilted and two openings in the table plate allow discharging the filler material/ oil in pots located below the table. This table is constructed to allow a load of 300kg what is the maximum weight of the Liner+Sealing Tester (filled with ceramic beads in the annulus and hydraulic oil in the interior). Also the size of the cover is suitable to the largest test bed.



Figure 28: Wooden Table with Cover

But what is even more important is the wooden frame and the Plexiglas cover. Therein the test beds can be placed for safety reasons. This frame can be lifted by handles from the table to allow placing the test beds before putting the cover above. The Plexiglas at the top can be opened to have access to the test cells during the testing processes. The cover protects when due to the high inner pressure of up to 700bar oil is squeezed out of the test cells, a sealing is leaking or a screw loosens. A little hole in the frame allows guiding the hydraulic line from the hand pump to the tester.

But nevertheless, the thickness of the wooden plates can just stand squeezed out oil and not if a thread of a lock screw or a connection totally fails. Therefore it is always of extreme importance to never stand in front of the end plates when the tester is subjected to inner pressure because the G1/4in connectors (manometer, pump) there present the weakest spot of the whole system. It is an option to place metal plates at the front and the end of the cover therefore.

Hoisting Equipment

When filling the test cells it is important to do that in an upright position or at least in a tilted position to not trap air inside. Also when discharging the hydraulic oil and the filler material the testers have to be tilted. Therefore a chain hoist is used (pulling capacity of 1000kg) that is attached on the 2.2m high framework to be used in conjunction with the wooden bench (lower horizontal bar is fixed below the table plate).

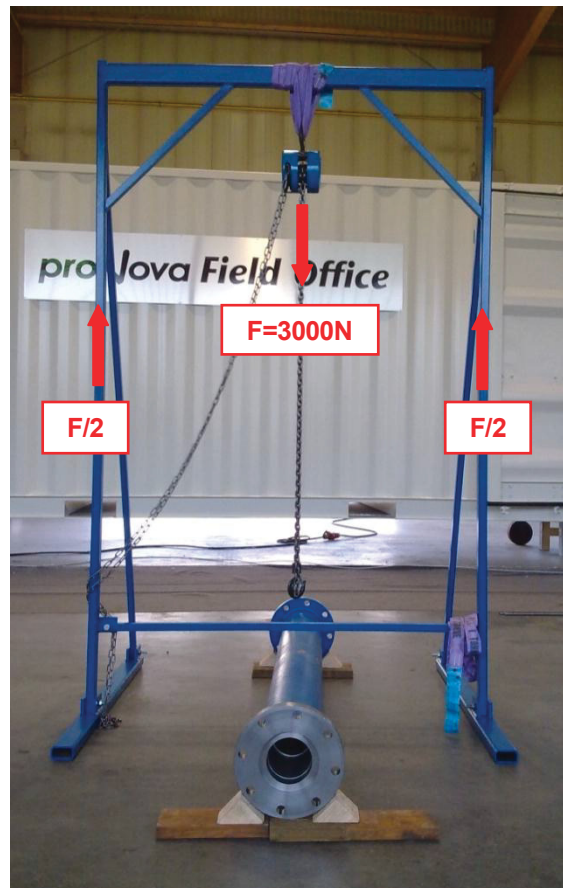

Figure 29: The Hoisting Equipment

The frame was built out of square construction pipes. Most parts were welded together but the beam in the lower section is attached with screws to iron plates. This is because the frame has to be used cross to the table. A fixed connection there would make it impossible to move the frame.

The material is S235 having a yield strength of 235N/mm². In the following it is calculated if the construction can pull the load of 300kg of the main tester. Only the main framework (two vertical and one horizontal pipe) are taken into consideration. The reinforcements make the framework again much stiffer and stronger.

At first the bending of the horizontal beam (70x30 external and 50x20 internal dimensions) under a load of 300kg is calculated. To have a much higher section modulus the pipe is welded on the frame in an upright position.

Together with the shear force at the welding seam the equivalent stress and from that on the safety can be calculated.

The bending stress of the upper horizontal bar can be calculated by having a maximum allowable load of 300kg (max. weight of largest assembled test bed including filler material and hydraulic oil). This gives a load of 3000N (F) what is 1500N for each vertical pole.

The horizontal beam has a length of 1300mm (a; this is needed to use the frame over the width of the table). The bending moment is therefore:

$$Mb = \frac{F}{2} * \frac{a}{2} = 975Nm$$

The section modulus (SM) against bending for the cross-section of the horizontal beam in an upright position [32] is now calculated.

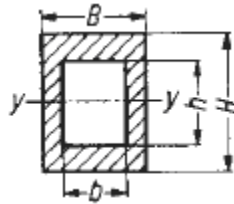

Figure 30: Cross-section of horizontal beam [32]

$$SM = \frac{BH^3 - bh^3}{6H} \tag{Eq. 34}$$

Inserting the dimensions:

H...70mm

B...40mm

h...60mm

b...30mm

gives a SM of 17238mm³ and the bending stress can be calculated:

$$\sigma_b = \frac{Mb}{SM} = 56.6MPa$$

Also the shear force plays a major role and can be calculated by taking into consideration the area of the cross-section (A):

$$\tau_{shear} = \frac{F}{A} = 3MPa$$

From the bending and the shear stress, the equivalent stress (σ_v) is calculated:

$$\sigma_v = \sqrt{\sigma_b^2 + 3\tau^2} = 56.8MPa \tag{Eq. 35}$$

As the beam is from S235, having yield strength (R_e) of 235N/mm², the safety can be calculated:

$$S = \frac{R_e}{\sigma_v} = 4$$

Also the resistance to buckling for the two main vertical pipes has been evaluated according to Euler [34].

The critical buckling load (F_c) is evaluated according instance 1 (assumed as “worst-case” that upper end of the vertical bar is not guided or fixed).

$$F_c = \frac{\pi * E * I}{lk^2} \tag{Eq. 36}$$

Wherein:

I ... area moment of inertia according the axis y (case 1) or the axis x (case 2)

$$I = \frac{1}{12} * (BH^3 - bh^3) \tag{Eq. 37}$$

The dimension of the cross-section of the vertical pole for case 1 are:

B ...30mm; H ...40mm; b ...24mm; h ...34mm

resulting in $I_y = 81392\text{mm}^4$

The dimension of the cross-section of the vertical pole for case 2 are:

B ...40mm; H ...30mm; b ...34mm; h ...24mm

resulting in $I_x = 50832\text{mm}^4$

This makes clear that buckling will first occur according to the x -axis of the plain. So from now-on only case 2 is considered.

E ... Young's Modulus of 2.1×10^5 MPa for steel

lk ... effective buckling length that is according to Euler instance 1 two times the length of the beam = 4400mm

The critical buckling force (F_c) divided by the actual applied force gives the safety for buckling.

$$S = \frac{F_c}{F} = 1,15$$

NB: when mounting the lifting slings like shown in the picture, it is possible to double their hoisting capacity what is therefore 2000kg.



Figure 31: Using the Bench and the Hoisting Equipment (right for oil discharge)

Pressure Testing in the Shop

Safety Rules for Inner Pressure Test Beds

- Never exceed pressure of **700bar**
- Never use test beds without the wooden side-frame and the Plexiglas cover
- Optional: insert metal plates at the front and end inside the wooden frame
- Secure the frame on the bench and ensure that sealing lips between frame and cover are in good shape
- Ensure secure position of pipe on table and good and horizontal stand of table
- Ensure that sealing o-rings used in the test beds are in good shape as well as that the groove is free of grease
- Ensure that all air is vented before usage - totally fill the test bed with hydraulic oil in an upright position so that no air can be trapped
- Never stand in front of the outlets (end plates)
- Ensure that all connections are tightened (torque according to test bed description)
- Never loosen or tighten a connection or screw under pressure
- If test cell is kept pressurized over a longer period, inform staff in the shop, close off the area around the test bed and put up warning signs
- Always totally bleed off pressure before working on the test bed (e.g. discharging the hydraulic oil)
- Only use hydraulic hand pump for pressurizing the cell; do not use pipes or tools to elongate the lever of the hand pump
- Wear safety glasses (squeezing out of oil) and safety shoes (heavy weight parts)
- Do not exceed the weight of 300kg for hoisting equipment
- Always monitor the pump connection, manometer and screws in the end plates of the tester – the pump and pressure gauge connection are representing the weakest points of the system
- If screws are turned out off the end plates, immediately bleed off pressure (therefore use hand pump)
- If manometer is indicating a pressure drop: stop pumping
- Ensure that hydraulic lines are in good condition and not bent too hard
- When using the high pressure ball valves, do not keep the pressure too long/ keep in mind the reduced pressure rating of these valves (500bar) NB: ball valves for standing more than 700bar (next size: 1000bar) would cost by far more because this is already not high pressure rated but highest pressure available
- For assembling and filling the test beds: before testing it is very important to vent the hydraulic lines. Therefore the ventilation bore (that should be on the highest spot) is opened and some pump strokes are performed until only oil seeps out at that bore.

Pressure Testing the Liner Assembly

Sealing-Only Tester

Testing Arrangement and Procedure

Recommendations for Assembling and Test Layout

When assembling the test bed – what should be only done right before testing – the end plate having the circular opening in the middle is mounted first on the pipe end with the enlarged inner diameter by using four M20 10.9 screws. A torque between 450-500Nm depending on lubrication and friction factors is recommended [34]. Then the modified nut is placed. The nut is kept in position by using a customized cone wrench (as shown on the photo) and a suitable ring spanner. Then the pin together with the two metal rings is inserted and tightened using the switch with the elongation and the torque wrench. The torque therefore is 1580Nm what is the average for the range from 790Nm ($\mu=0.1$) to 2370 ($\mu=0.3$). When using the elongation with an overall length of 3715mm (3100mm lever and 615mm wrench) the wrench should be adjusted to set off at 262Nm when applying a load of 425N (42.5kg). When considering the weight of the elongation itself then only 210Nm have to be set because this torque is added after the wrench. When tightening the pin in the nut, two things are important: at first all threads as well as the surfaces of the metal seals have to be lubricated by using copper paste to achieve a suitable (recommended) friction factor. And second the pipe has to be secured in the fixation prism. This ensures that the pipe is not turned when tightening the pin.



Figure 32: Cone Wrench to hold Modified Nut while tightening Pin



Figure 33: Optional Socket Wrench for Pump Connection



Figure 34: Switch for tightening Pin

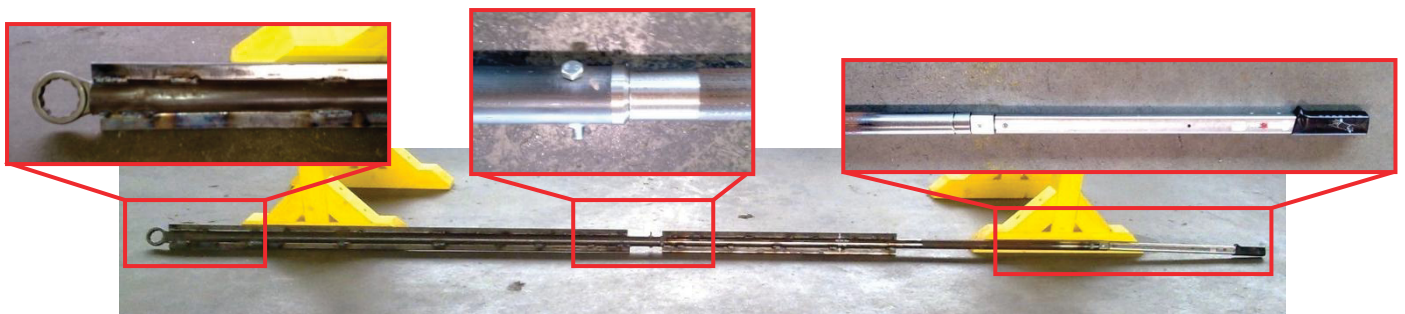

Figure 35: Elongation Lever for Torque Wrench

For the elongation lever some considerations were necessary before using: Having a torque of approximately 1500Nm at the end of the ring wrench, a force of approximately 400N (40kg) has to be applied at the torque wrench. Considering the section modulus for the two pipes (S235) that are different in OD and ID, it became obvious that both front (left) ends of the pipes have to be reinforced to avoid bending. Therefore the two joined pipes were reinforced with rectangular flat iron bars that are welded on the top and bottom in an upright position. Adding the section modulus of the iron bars, the elongation lever can stand the bending moment along the whole length. A plug insert of full round steel is connecting the two pipes to have no kinking at that crucial spot.

Afterwards the o-ring is inserted in the groove of the pipe. This groove should be free of grease and lubrication. The second end plate with a cleaned sealing surface is mounted like the other before.

When connecting the hydraulic hand pump to the modified nut a crossover connector to G1/4in is needed. A ball valve should be connected to the hydraulic hose of the pump and from that valve another hose is guided to the test bed. This valve allows locking the pressure inside the tester for long term pressurizing the sealing elements.

Then the thread for the manometer is closed by a G1/4in plug. Now the chamber can be filled with oil in an upright position until oil is seeping out at the ventilation hole. Then the fill port is closed and the manometer mounted. After venting the hydraulic lines also this bore can be closed. Always using Teflon tape and copper washer for sealing-off the threads. Now the test bed is ready for testing and pressure can be applied until a pressure drop is indicated at the manometer. This gives the maximum pressure rating for the metal seal rings.

Assembling Procedure in Pictures

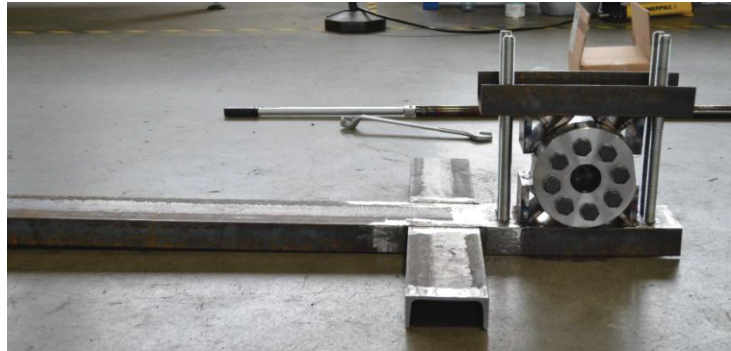

Figure 36: Main Pipe in Fixation Prism



Figure 37: Testbed in Fixation Prism with Axial Fixation ready to apply Torque



Figure 38: Filling of the Test Cell in upright Position



Figure 39: Test Bed ready to apply Pressure

Testing Results

At first the objective of the testing was to pressurize the metal seal rings to the maximum possible pressure.

Two days after tightening the pin to 1580Nm, it was tried to retension the seal group but no settlement occurred and the torque of 1580Nm was still present. Then the testcell was assembled, filled and pressurized to the maximum pump output that was reached at 680bar. No leakage occurred.

Afterwards a long term test was carried out. Therefore the ball valve was used to lock the pressure inside the test cell. The pressure was kept above 640bar for 19hours. The first 5hours of the test are shown in the chart below. During the whole time no leakage at the metal rings (or any other spot of the test cell) occurred. After disassembling it was possible to examine the annular space that was sealed with the metal rings. This surface was totally clean and no oil film was present (Figure 40). Before also the torque of the pin in the nut was checked. Again the torque of 1580Nm was kept.

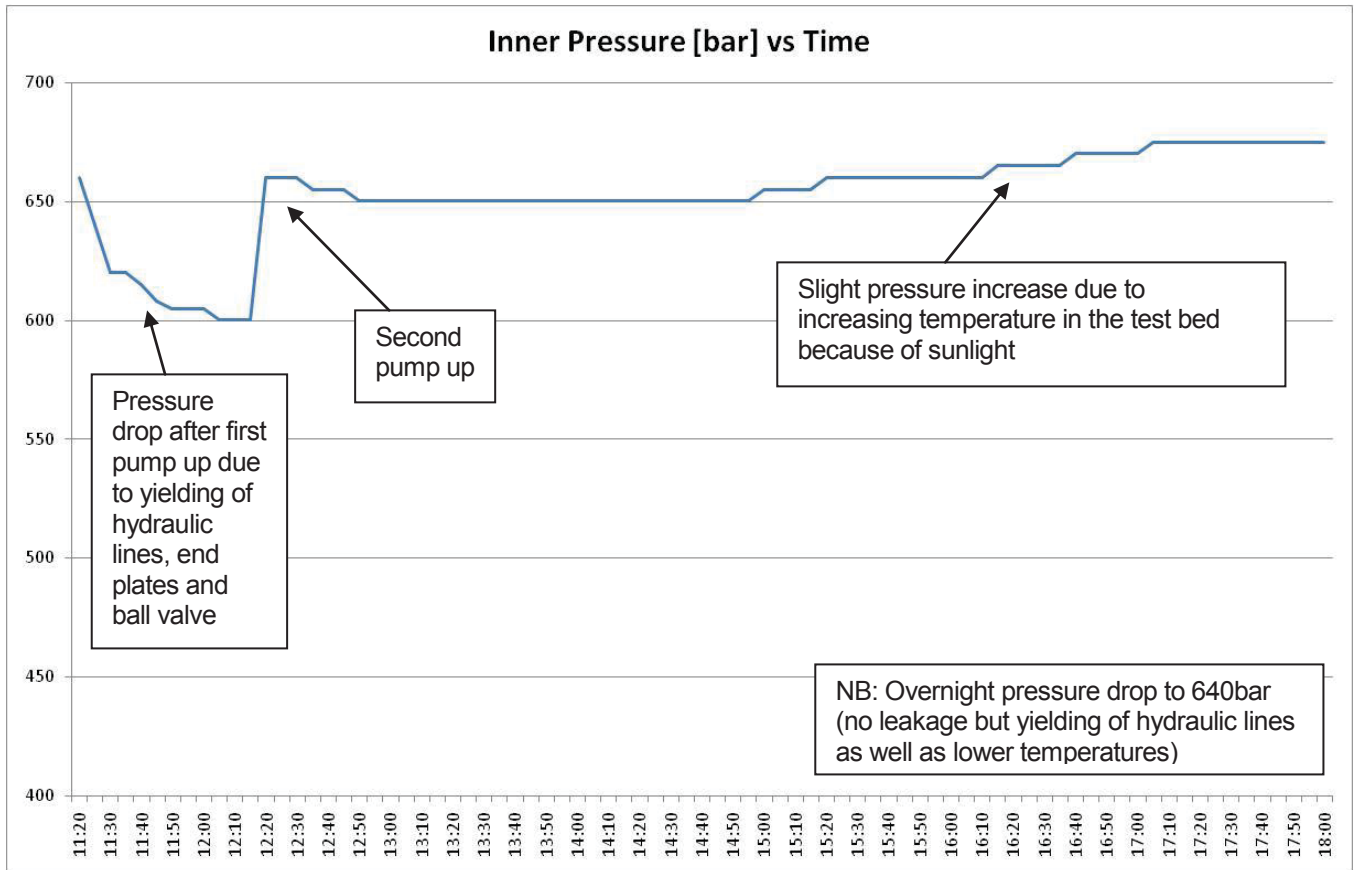

Figure 40: Time vs Pressure Chart

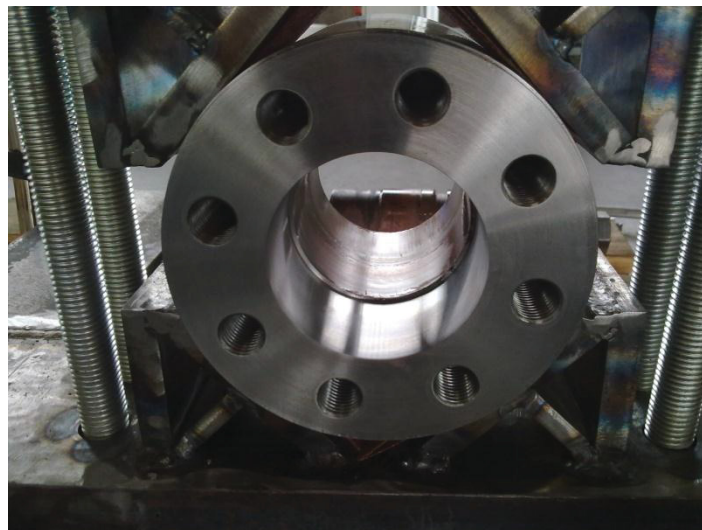

Figure 41: Main Pipe after Testing

Conclusion

- There is no need to retension the metal seal rings for service purpose
- The metal seal rings can stand at least 640bar (probably more)

Liner&Sealing Tester

Testing Arrangement and Procedure

Recommendations for Assembling and Test Layout

When assembling the test bed at first the cylindrical insert of the box-end is screwed on the fixation nut of the liner tube (fixation nut and nut already welded on the tubular). This is done by using a fixation prism and the two installation tools that are presented in the picture below. The larger one should be attached to the backside of the cylindrical insert and fixated by using four M6 10.9 screws. The smaller tool should be engaged from the front side to the fixation nut by using again M6 10.9 screws that are fasten in the bores for filling. It is important to take high strength screws to prevent shearing off the bolts when turning the liner into the cylindrical insert. Although using the 10.9 screws what makes possible to apply a torque of more than 2,000Nm, the liner is only screwed in the cylindrical insert to a point where the plain end of the fixation nut is still in front of the plain end of the cylinder (ensures the contact of the o-ring with the end plate). This can be done without monitoring the applied torque because with a lever length of 1m more than 200kg have to be applied to go above the allowed 2000Nm that the screws can hold.



Figure 42: Tools for Liner&Sealing Test Bed

Then the cylindrical insert at the pin-end is just placed in the main pipe. The liner assembly together with the box-insert is place in the main pipe. The lubricated pin of the sealing group together with the inner and the outer metal ring is screwed in the nut of the liner. Therefore the same switch as for the Sealing-Only Tester that is described above is used. The two installation tools from the working step before are also used again: The larger one is used like before (again M6 10.9 screws) to hold the cylindrical insert at the pin-end in place so that it is not turned with the metal seal rings. The smaller installation tool is engaged at the other end of the liner, at the front of the fixation nut (same procedure: use four M6 10.9 screws) to counterforce the liner itself when fastening the pin at the other end to compress the metal seal rings to force them against the main pipe wall. As mentioned for the Sealing-Only Tester, this pin should be tightened in a range from 790Nm for a μ of 0.1 to 2370Nm for a μ of 0.3. As long as the friction factor is not known when assembling the test bed only assumptions can be made. For metal on metal that is slightly oiled and lubricated a friction factor quite in the range of 0.1 to 0.3 can be assumed. Therefore the pin of this seal group should be again tightened to the average of 1580Nm. Depending on the torque applied, the levers for the mounting tools have to be reinforced or elongations have to be used.

After the liner is fixed in the main pipe, the annular volume between liner tube and main pipe can be filled with the ceramic beads. Therefore the test bed should be brought to vertical with

the fixation nut on top. Prior to filling, the eight studs are inserted in the corresponding holes in the middle of the main pipe. The studs are contacting the liner tube with their lower end and are connected and kept in position via a thin wire. This wire should have a certain degree of elasticity to not force the studs against the inner tube when pressure is applied.

For filling two funnels were customized. As shown in the picture below, the smaller funnel is fit in the seal ring groove of the fixation nut and the other funnel ring is fixed at the edge of the nut. This gives a double cone shape what makes it easy to fill the annulus by gravity. Knocking with a rubber hammer during the filling process should compress the filler material. After about 6l of the material have gravitated down, the annulus can be regarded as filled. The inlets (bores for filling) can be plugged by four M6 allen screws of the length of 15mm.



Figure 43: Funnels for Filling the Liner&Sealing Test Bed

Now the test cell can be closed. The rubber sealing rings can be placed in the corresponding grooves of the fixation nut at the box-end and the cylindrical insert at the pin-end of the test bed. Then the end plates are mounted by using eight M20 10.9 screws with a length of 120mm and washers and nuts. A torque between 130 and 500Nm should be applied. The lower limit is the required pressing force for the 95 shore A hard o-ring and the upper limit is the approximately pre-loading force for a 10.9 screw [35].

If the test bed is filled with the hydraulic oil in a vertical position, the thread for connecting the hydraulic pump is first plugged with a G1/4in seal plug. Then the outlet for the oil on the other end of the tester is closed by using a M16 10.9 screw (do not forget to use Teflon sealing tape on the threads and a copper washer for better sealing). The manometer can also be attached by using sealing tape again. The ventilation hole is kept open and the oil can be filled in the test chamber until oil seeps out. Then the both remaining openings are closed in the same manner as before. The test bed can also be filled with the hydraulic oil in a slightly slanted but still horizontal position. Therefore it is important to tilt the test bed in a way that the ventilation hole is on the highest position. When filling that way, it is possible to connect the hydraulic pump prior to the filling process. If it is intended to keep the pressure in the test cell over an extended period of time, a ball valve should be installed between the pump and the test bed. Therefore a second hydraulic line can be used. Again also the lines must be vented.

During increasing pressure it is important to measure the studs in the middle section of the pipe to know if there was an expansion of the liner.

Disassembling

After testing, pressure is bled off by using the hand pump. After discharging the oil by tilting the test bed, the end plates can be removed and the pin of the seal group is now loosened. The liner can be pulled out off the main pipe by using M6 ring screws in the bores of the cylindrical insert at the box-end. Then the liner tube can be examined.

Redesign

The tests have not been carried out yet because it is under discussion to use a thicker walled tubular made of higher strength material that is covered outside with a carbon layer. This might make it possible to get rid of the filler material. To test the new liner design plus the composite layer it might be necessary to change the ID of the cylindrical pin insert from 83mm to 85mm (depending on new liner design).

Protective Bushing Tester 1

Testing Arrangement and Procedure

Recommendations for Assembling and Test Layout

When assembling the test cell the given order should be followed:

At first the pin insert is fixed in the end plate – not forgetting about the o-ring. Then the left end plate is mounted on the main pipe using M20 10.9 screws (length 120mm) and tightened like for the other test beds. After this the pipe should be brought to vertical, having the open end at top. This allows inserting the protective bushing (lubricated nose). The middle plate and the end plate are mounted using M20 10.9 screws (length this time 145mm). After torquing, the steel ball and the motion screw is inserted. The screw is turned in until resistance is felt. The filling process is done again vertical. The connections of the pump and the manometer, the lock screws (10.9) of the inlet/outlet as well as of the ventilation hole are installed like for the other test beds using Teflon tape and copper washers. NB: As there is limited space, it might not be easy to apply the spanner wrench for tightening the M16 screw of the oil inlet for example. One possible solution is to close the G1/4in threads with small lock allen screws during filling before screwing there in the manometer and the pump that need more space. The M6 screw having the smallest head can be the last.

The target of the testing is now to figure out how much compression of the nose of the bushing is needed to create a hydraulic seal for pressures at least similar to the pressure rating of the metal seal rings. The movement (and by that the compression – called axial tightness) of the protective bushing can be adjusted by the motion screw. For creating a seal the contact pressure should be equal or higher the inner pressure. According FEA a seal for 500bar inner pressure should be established for axial tightness between 0.13 and 1.15mm.

Spare protective bushings are stored in the workshop that are only pre-worked to their basic shape and dimensions in order to only have to manufacture different nose geometries.

Assembling Procedure in Pictures

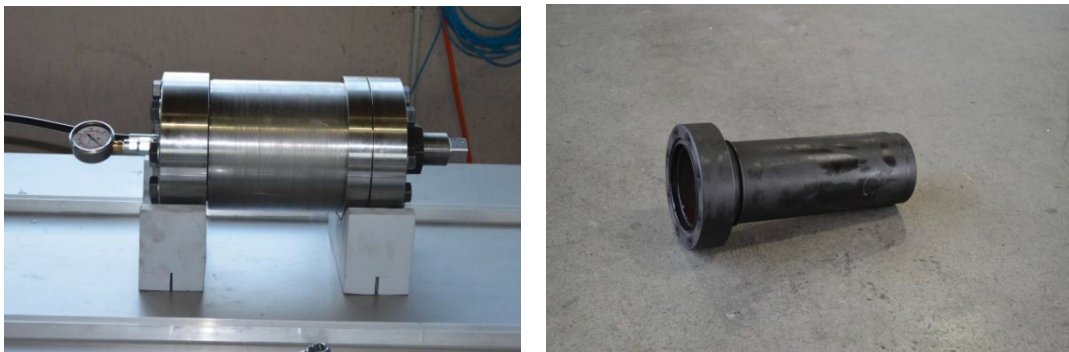

Figure 44: Exterior and Interior of the Test Bed



Figure 45: Filling of the Test Bed

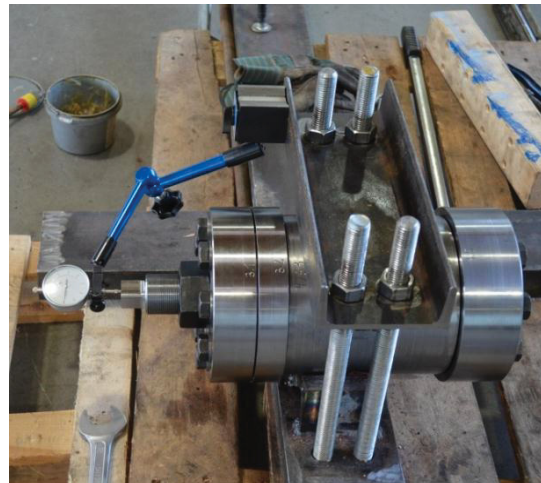

Figure 46: Using a Dial Extensometer for adjusting the Axial Tightness

Testing Results

After the first contact of the nose of the protective bushing in the pin insert (motion screw only hand-tight), the lowest value for the axial tightness (0.15mm) was tested. The maximum pressure that could be applied was only 400bar. In the next step, an axial tightness of 0.32mm was tested and leakage occurred already at 450bar.

Also remarkable that almost the whole preloading of the protective bushing was lost during pressure testing.

All dimensions of the protective bushing were recorded before and after testing but did not change. The nose was also examined in the microscope but no major wear (equal on the circumference) was visible.

The distance the motion screw is pushed out of the test bed when pressure applied was roughly measured by using the extensometer on a bow (figure below). For that amount the axial tightness is reduced.



Figure 47: Test Setup for the Extensometer

Preload before Test (axial tightness) [mm]	Max. Pressure before Leakage [bar]	Reduction in axial tightness [mm]	Residual Preload after Test [mm]
0.15	400	0.04	0,05
0.32	450	0.06	0.05
0.50	540	0.11	0.10

Conclusion

The nose of the protective bushing should have the same pressure rating as the rest of the liner system. Therefore further investigation is necessary.

In a next step it is necessary to precisely measure the distance that the motion screw is pressed out of the test bed under pressure because of the closed end of the protective bushing. It might be that the inner pressure pushes the nose out of the seat in the pin insert. If that is the case it is necessary to increase the axial tightness (axial movement of the motion screw) to account for that effect. But thereby it is important to not enter the plastic region.

To be closer to reality it might be necessary to create a hybrid out of the two protective bushing tester to test a “real” protective bushing. The second possibility would be adapting the “300” test bed in a way that the same pressure acts also from behind on the protective bushing.

Protective Bushing Tester 2

Testing Arrangement and Procedure

Recommendations for Assembling and Test Layout

The assembling procedure follows the same principle as for the other test beds. But basically the protective bushing should be first mounted in the liner nut. Therefore the mounting tool below can be used (6 bores for 6 10.9 screws and V320 lever). The bushing itself is kept in place in the fixation prism. For tightening a torque of 1097Nm should be used (middle value for a friction factor ranging between 0.1 and 0.3). Therefore use torque wrench with same elongation lever as before. The torque wrench is therefore set to trigger off at 110Nm (length and self-weight of elongation taken into consideration). Then the middle plate is mounted in the fixation prism and the nut with the protective bushing having still the mounting tool on is screwed in (same torque). This assembly is inserted in the main pipe. The o-rings are installed and the end plates are mounted (same as for the other test cells). It can be tricky to keep the o-rings in position because the o-rings having a rather high hardness (95 shore A) for a radial placed o-ring. The connection of the pump and the manometer as well as the filling and plugging follows the same procedure as for the other test cells (filling in upright position).



Figure 48: Tool for Protective Bushing Test Bed 2

Pressure is built up inside, until a pressure drop can be observed. This gives the pressure rating for the threaded end of the protective bushing.

In case of not working or too early pressure drop again spare parts (protective bushing) are available.

Assembling Procedure in Pictures



Figure 49: Protective Bushing screwed in Liner Nut (hand tight) with Ring of Mounting Tool

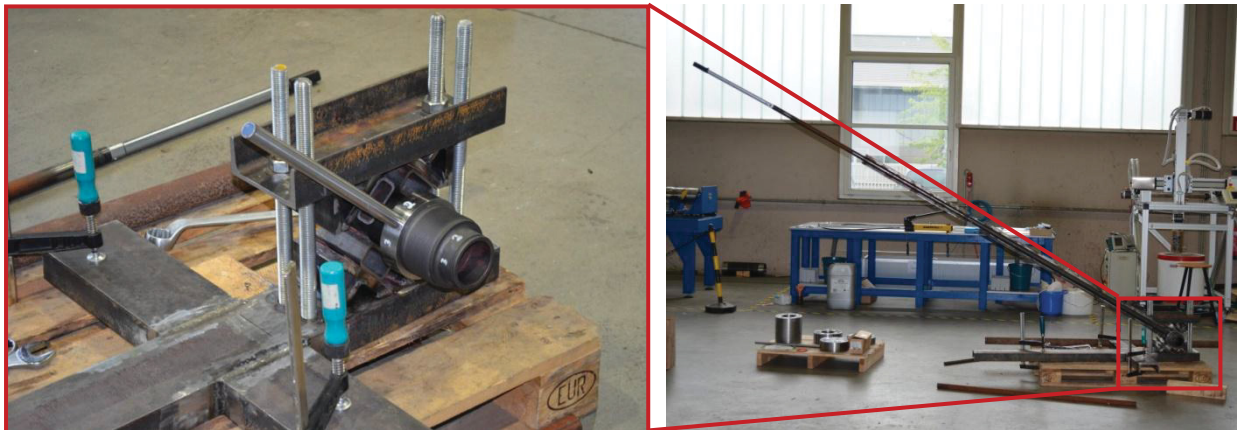

Figure 50: Protective Bushing in Fixation Prism to apply Torque

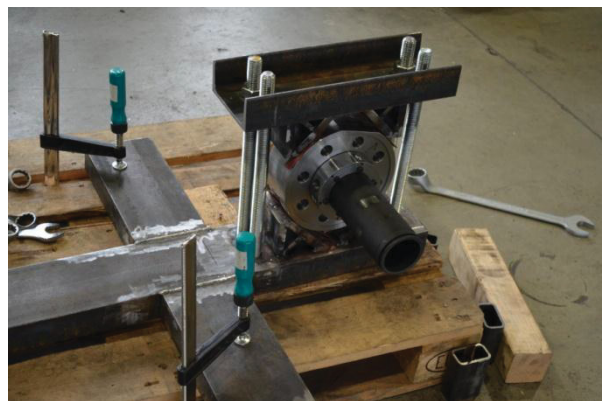

Figure 51: Middle Plate with Protective Bushing in Fixation Prism



Figure 52: Mounting O-rings and End Plates



Figure 53: Preparing for Testing

Testing Results

The test cell was pressurized to the maximum pressure output that was reached at 660bar. After this first pump-up the pressure dropped – as expected – slightly (air dissolves in oil, backflow in pump, deformation of end plates, hydraulic lines, screws...). After a second pump-up the pressure was kept at 640bar for more than 5hours without any leakage. After additional 17hours the pressure dropped to 620bar (small leakage at filling port). When disassembling the test cell afterwards, no oil in the annulus could be found (only little greasy film at the ending of the thread due to the mounting paste).

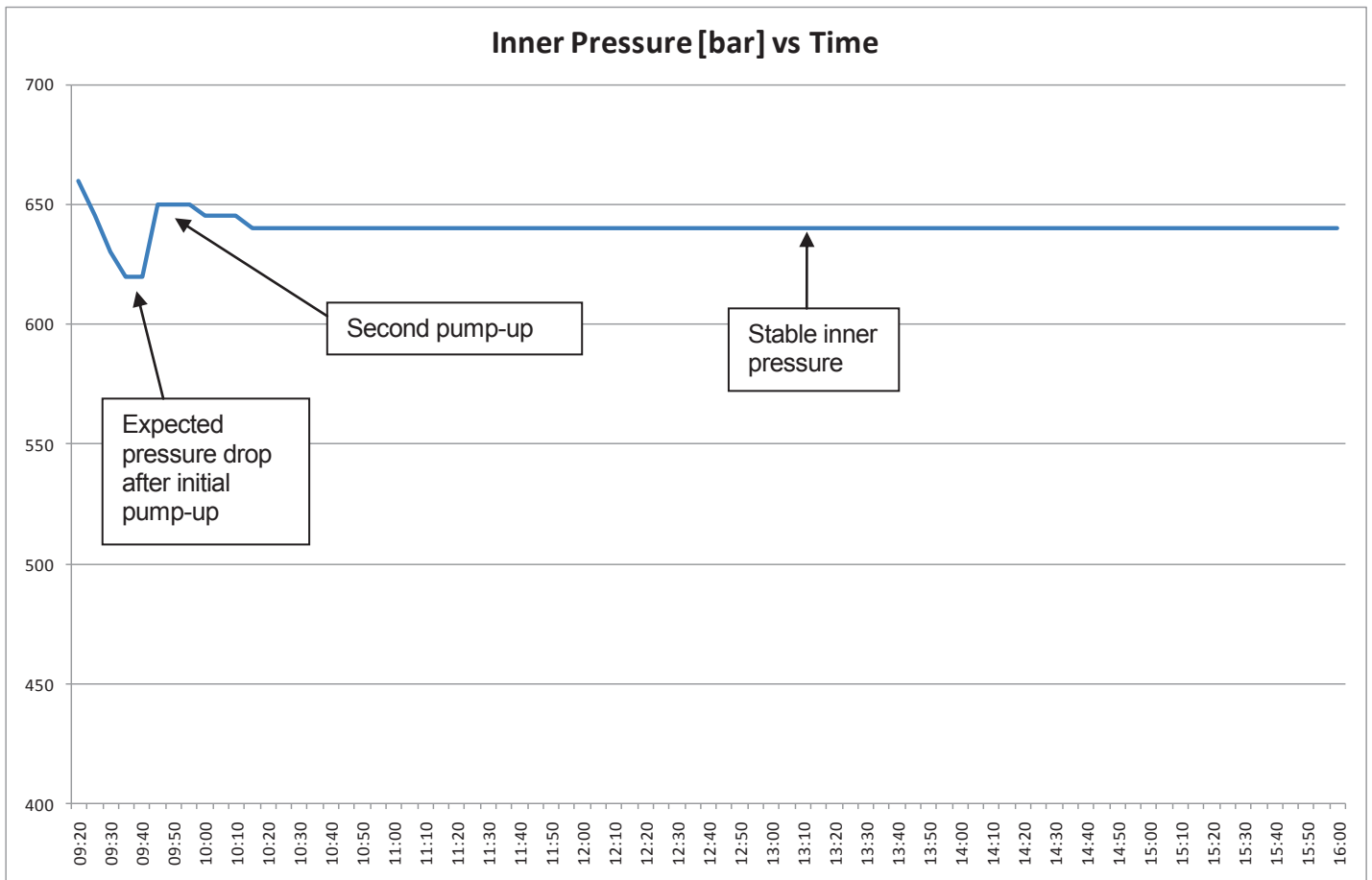

Figure 54: Time vs Pressure Chart



Figure 55: Oil-free Inner Components after Testing

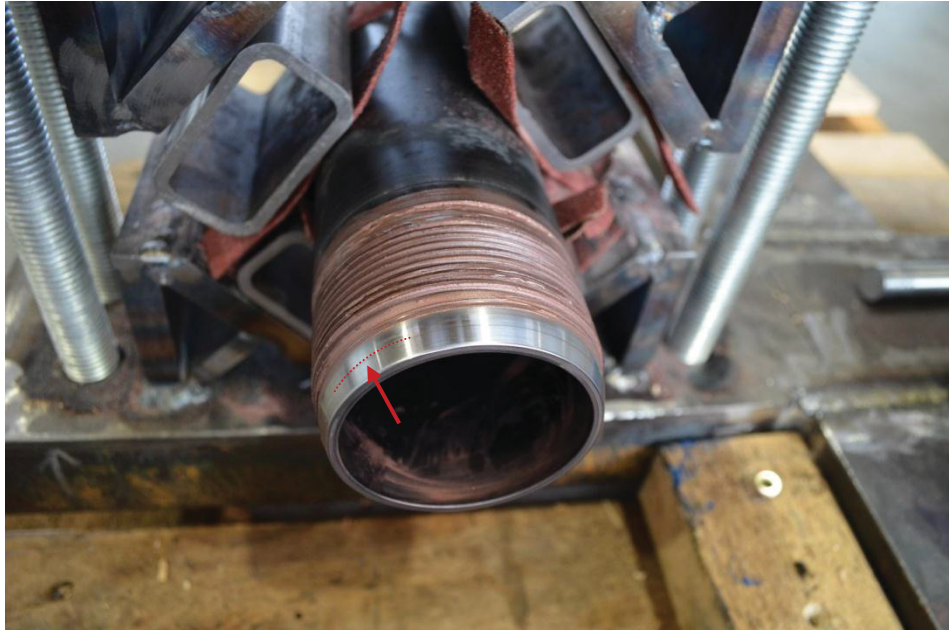

Figure 56: Circumferential Contact of Protective Bushing in Liner Nut

Conclusion

- The thread of the protective bushing can stand at least 640bar

Conclusion

It was possible to design several test beds according to pressure test the proposed inner liner system that is placed inside an internal-external 5in – 19.5lb/ft – G105 drillpipe. The maximum pressure that could be applied to the test beds is 700bar. All given requirements stated at the beginning were fulfilled.

In the following the results of the pressure tests for the three crucial spots within the liner system are summarized:

Metal Seal Rings

- The metal seal rings can stand at least a pressure of 680bar (the maximum pressure output of the hydraulic pump was reached)
- During the long-term test the inner pressure was kept above 640bar for 19hours and no leakage occurred
- There is no need for retensioning of the metal seal rings

Protective Bushing – Threaded End

- The threaded end of the protective bushing can stand at least 660bar (the maximum pressure output of the hydraulic pump was reached)
- For the long-term test the pressure in the test bed was kept above 620bar for 22hours without leakage

Protective Bushing – Nose

- Up to now 540bar was the maximum pressure that could be applied before leakage occurred
- After pressure testing almost all preload of the protective bushing was lost
- Further investigation and tests are necessary because the nose of the protective bushing should have the same pressure rating as the rest of the liner system
- Therefore the next testing steps should involve:
 - Measuring the distance that the protective bushing might be pushed out of the pin insert when pressure is applied. To account for that, the axial tightness has to be increased by that amount in the next test.
 - In the actual test bed design the end of the protective bushing is closed. This does not exactly depict reality and might have a stronger influence than thought. One solution could be to create a “hybrid” of both protective bushing testers in order to be able to test the nose of a original protective bushing having no closed end. Therefore only the end plates on the main pipe have to be exchanged.
 - If the pressure tests still are not satisfying, the axial tightness has to be increased in general.

Abbreviations

μ ... friction factor [-]	l ... length of thread engagement [mm]
A ... cross-section [mm ²]	MA ... torque [Nm]
A_1 ... nominal area of screw [mm ²]	MD ... Measured Depth [m]
A_n ... affected area [mm ²]	MW ... Mud Weight [kg/m ³]
A_{sub} ... substitutional cross-section [mm ²]	OD ... Outer Diameter [mm]
b ... length of screw [mm]	OH ... Open Hole
csg ... casing	p ... pitch of screw [mm]
d ... basic diameter of screw [mm]	P ... Pressure applied [bar]
D ... Diameter [mm]	p_e ... external pressure [bar]
d_2 ... pitch circle diameter screw [mm]	p_i ... inner pressure [bar]
d_3 ... core diameter of screw [mm]	PV ... Plastic Viscosity [cp]
D_A ... affected diameter [mm]	r ... radius [mm]
DC ... Drill Collar	R_e ... Yield Strength [N/mm ²]
De ... external radius [mm]	r_i ... radius inner wall [mm]
dh ... bore diameter for screw [mm]	R_m ... Tensile Strength [N/mm ²]
Di ... internal radius [mm]	r_o ... radius outer wall [mm]
DP ... Drillpipe	S ... Safety factor
d_w ... diameter of screw head [mm]	s ... wall thickness [mm]
E ... Young's Modulus [N/mm ²]	SM ... Section Modulus [mm ³]
F ... Force [N]	t ... plate thickness [mm]
F_a ... axial force [N]	TVD ... True Vertical Depth [m]
FA ... force on screw [N]	ν ... Poisson's ratio [-]
F_c ... critical buckling force [N]	ν_1 ... type of welding seam
FK_{req} ... required pressing force [N]	ν_2 ... quality factor for welding seam
F_l ... lateral force	YP ... Yield Point [lb/100ft ²]
f_{sv} ... settlement of screw [μ m]	Δr_x ... Change of radius at x [mm]
f_{st} ... settlement of component [μ m]	δ_s ... settlement of screw [mm/N]
FVM_{min} ... minimum preload force [N]	δ_t ... settlement of component [mm/N]
FZ ... setting force [N]	σ_a ... axial stress [N/mm ²]
H_1 ... middle pitch height [mm]	σ_b ... bending stress [N/mm ²]
HHP ... Hydraulic Horse Power	σ_r ... radial stress [N/mm ²]
h_o ... spring deflection [mm]	σ_t ... tangential stress [N/mm ²]
I ... area moment of inertia [mm ⁴]	σ_v ... equivalent stress [N/mm ²]
ID ... Inner Diameter [mm]	φ ... pitch angle [°]
IEU ... Internal/ External Upset	φk ... setting factor screw/component [-]

References

- [1] ADS internal communication with J. Jud, A. Fine, A. Kotov; ADS design drawings Rev A4, TDE 54.500ff from spring 2012 (design work in process)
- [2] modified from ADS drawing ADS.54.400 by A. Kotov, 11 March 2012
- [3] A. Schweizer „Festigkeitsberechnung von Rohren und Behältern“ downloaded from www.schweizer-fn.de on 24 January 2012
- [4] Dieter Muhs et al. „Roloff/Matek Maschinenelemente“, 18th edition, published by Vieweg, 2007, Chapter 6 “Schweißen” (welding), C 6.3, p.171, picture 6-48
- [5] J.T. Finger et al. „Development and Testing of Insulated Drillpipe“, IADC/SPE paper 9144, presentation at the 2000 IADC/SPE Drilling Conference held in New Orleans, Louisiana, 23–25 February 2000
- [6] A. Kotov, FEA study: “Equivalent Stress and Contact Pressure Distributions in metal seal group”, ADS internal document, June 2012
- [7] A. Kotov and A. Fine, Integrity study: “FEA Pin x Protection Bushing sealing”, ADS internal document, March 2012
- [8] A. Kotov and A. Fine, Integrity study: “FEA Nut TDE.54.401 x Protection Bushing sealing”, ADS internal document, March 2012
- [9] M. J. Economides and T. Martin: “Modern Fracturing: Enhancing Natural Gas Production”, Chapter 8-3 Proppants, Energy Tribune Publishing Inc., Houston, 2007
- [10] Data Sheet “Keramikperlen” (ceramic beads) provided by Kugel Pomel company
- [11] Al T. Champness et al., Topical Report “Preliminary Design of Insulated Drill Pipe for High Temperature, High Pressure Drilling”, Drill Cool Systems, Inc., February 2007
- [12] Information available at <http://www.nov.com/intelliserv>, February 2012
- [13] American Petroleum Institute, Specification 7A, “Specification for Rotary Drill Stem Elements”, 39th edition, December 1997 (effective date: 1 June 1998)
- [14] Trelleborg “Static Seals”, Catalogue by Trelleborg Sealing Solutions, 2007
- [15] K.-H. Grote and J. Feldhusen “Dubbel - Taschenbuch für den Maschinenbau“, 22nd edition, published by Springer, 2007, Chapter 3 “Festigkeitslehre” (strength of material), C 5.1.2 “Kreisplatten” (circular plates), p.C34ff
- [16] Dieter Muhs et al. “Roloff/ Matek Maschinenelemente – Formelsammlung” (formulas), 8th edition, published by Vieweg, 2006, Chapter 10 “Elastische Federn” (elastic springs), p. 112/23 (TB 10-8a)
- [17] Dieter Muhs et al. “Roloff/Matek Maschinenelemente“, 18th edition, published by Vieweg, 2007, Chapter 8 “Schrauben” (screws), p.234ff
- [18] Dieter Muhs et al. “Roloff/ Matek Maschinenelemente – Formelsammlung” (formulas), 8th edition, published by Vieweg, 2006, Chapter 8 “Schraubenverbindungen” (screw connections), p. 74ff, formulas 19, 21, 32
- [19] Trelleborg “Static Seals”, Catalogue by Trelleborg Sealing Solutions, 2007, p.24, figure 17
- [20] Dieter Muhs et al. “Roloff/Matek Maschinenelemente“, 18th edition, published by Vieweg, 2007, “Tabellenbuch” (tables), Table: Tb8-10a
- [21] Dieter Muhs et al. “Roloff/Matek Maschinenelemente“, 18th edition, published by Vieweg, 2007, Chapter 8 “Schrauben” (screws) p8/9/76

- [22] Dieter Muhs et al. "Roloff/Matek Maschinenelemente", 18th edition, published by Vieweg, 2007, "Tabellenbuch" (tables), Table: Tb8-1,
- [23] information provided at www.gewinde-norem.de, January 2012 (DIN/ ISO 13 - metric regular thread; ISO 22-1 - BSP)
- [24] K.-H. Grote and J. Feldhusen "Dubbel - Taschenbuch für den Maschinenbau", 22nd edition, published by Springer, 2007, Chapter 7 "Mechanische Konstruktionselemente" (mechanical construction elements), p G39 (1.6 "Schraubenverbindungen" - screws)
- [25] Dieter Muhs et al. "Roloff/ Matek Maschinenelemente – Formelsammlung" (formulas), 8th edition, published by Vieweg, 2006, Chapter 8 "Schraubenverbindungen" (screw connections), p.75 formula 30
- [26] Dichtomatik "O-Rings Manual", provided by Dichtomatik Sealing Company, Hamburg, Germany
- [27] COG "Das O-Ring 1x1", provided by C. Otto Gehrckens GmbH & Co. KG, Seal Technology, Pinneberg, Germany
- [28] American Petroleum Institute, Specification 7A, "Specification for Rotary Drill Stem Elements", 39th edition, December 1997 (effective date: 1 June 1998)
- [29] Dieter Muhs et al. "Roloff/Matek Maschinenelemente", 18th edition, published by Vieweg, 2007, "Tabellenbuch" (tables), Table: Tb8-1
- [30] Dieter Muhs et al. "Roloff/Matek Maschinenelemente", 18th edition, published by Vieweg, 2007, Chapter 6 "Schweißen" (welding), C 6.3.4, p.172
- [31] Univ.Prof. DI Dr. W. Eichelseder and DI Dr. I. Godor "Machine Elements I", lecture notes, Chair for Mechanical Engineering, Mining University of Leoben, 2007/08
- [32] calculated with the thread calculation program at www.iso-gewinde.at
- [33] K.-H. Grote and J. Feldhusen "Dubbel - Taschenbuch für den Maschinenbau", 22nd edition, published by Springer, 2007, Chapter 3 "Festigkeitslehre" (strength of material), 2.4 "Biegebeanspruchung" (bending), p.C11, table 1
- [34] K.-H. Grote and J. Feldhusen "Dubbel - Taschenbuch für den Maschinenbau", 22nd edition, published by Springer, 2007, Chapter 3 "Festigkeitslehre" (strength of material), 7 "Stabilitätsprobleme" (stability problems), 7.1 "Knicken" (kinking), p.C39
- [35] information on high strength screws provided at www.wegerteder.com, January 2012

Appendix A – Pressure Loss Calculation

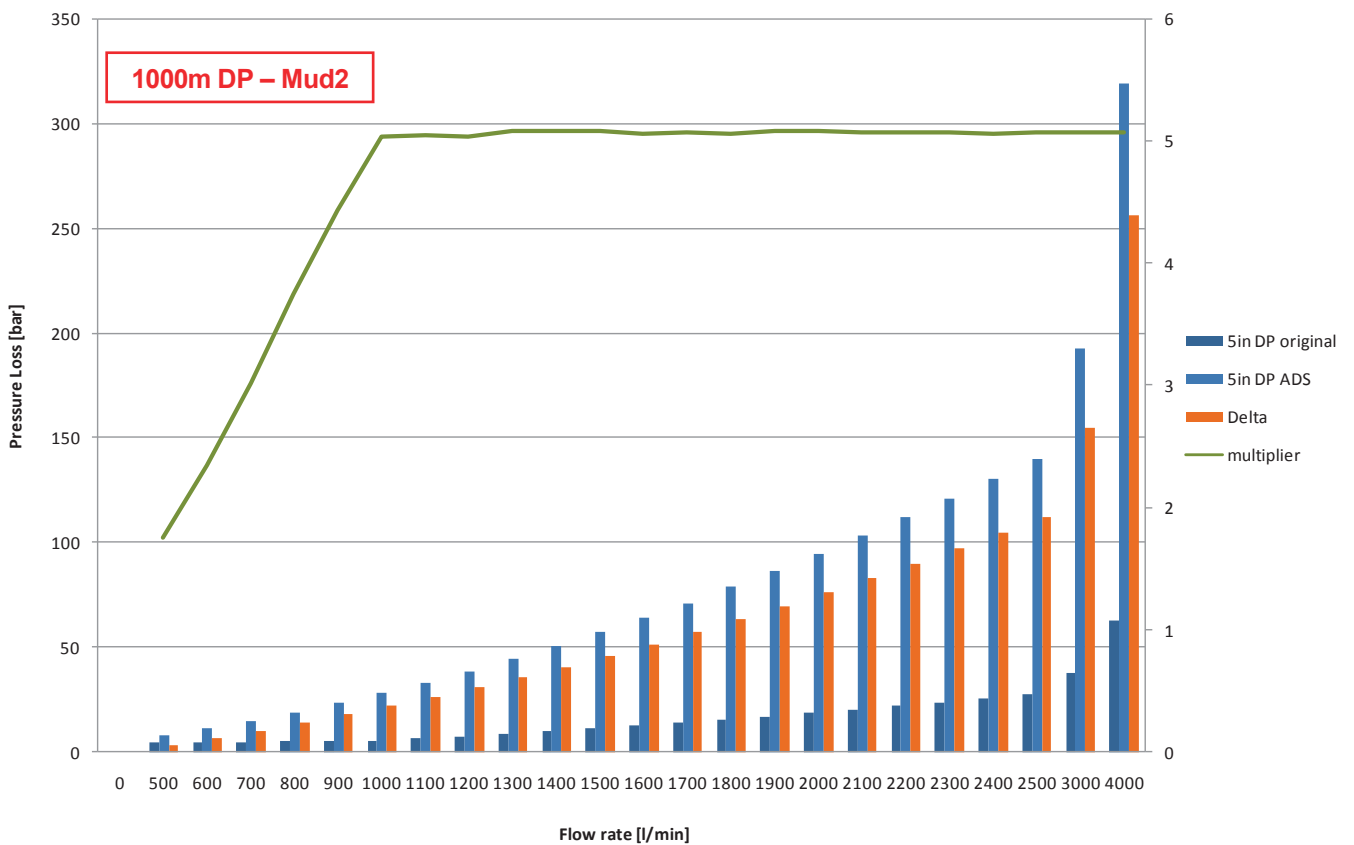
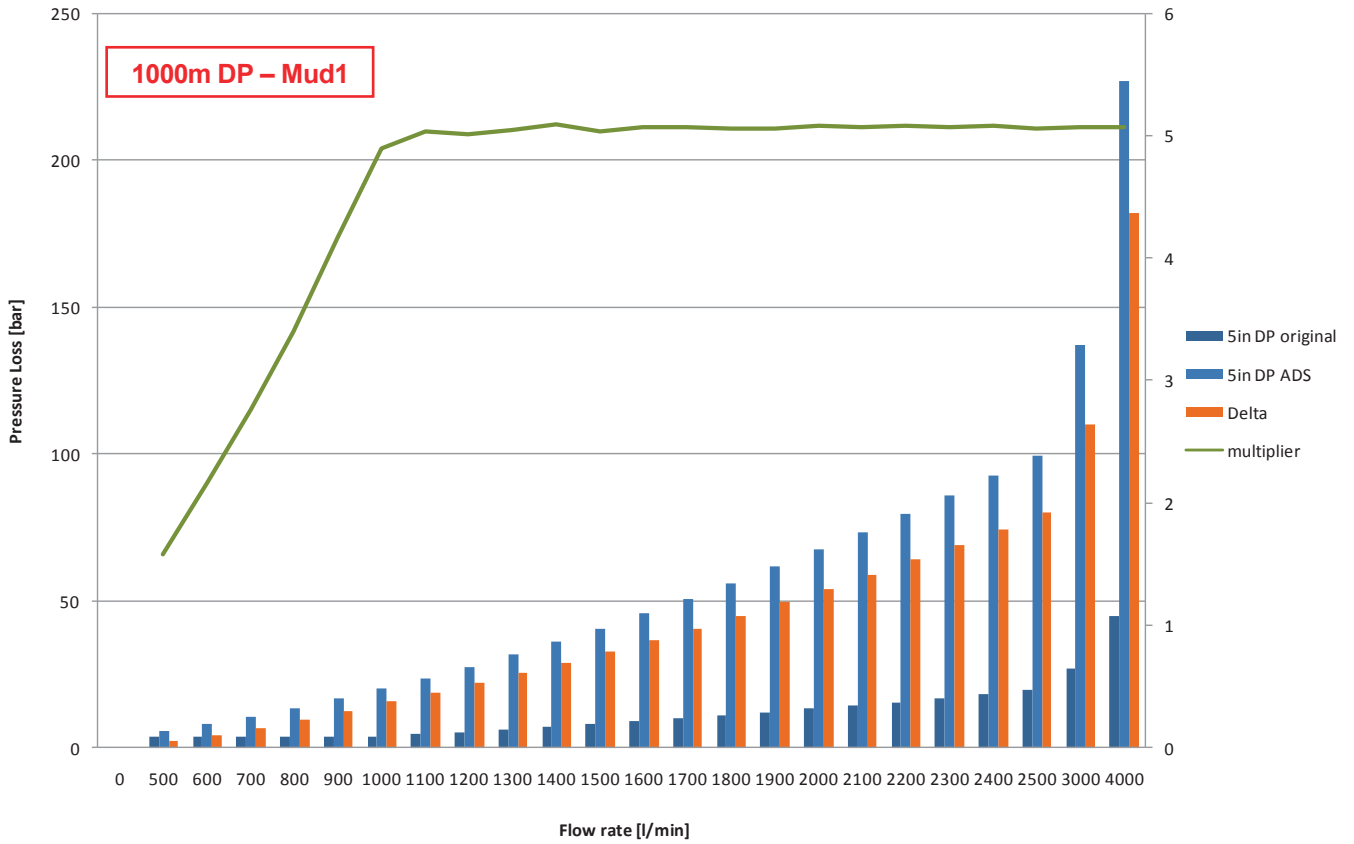

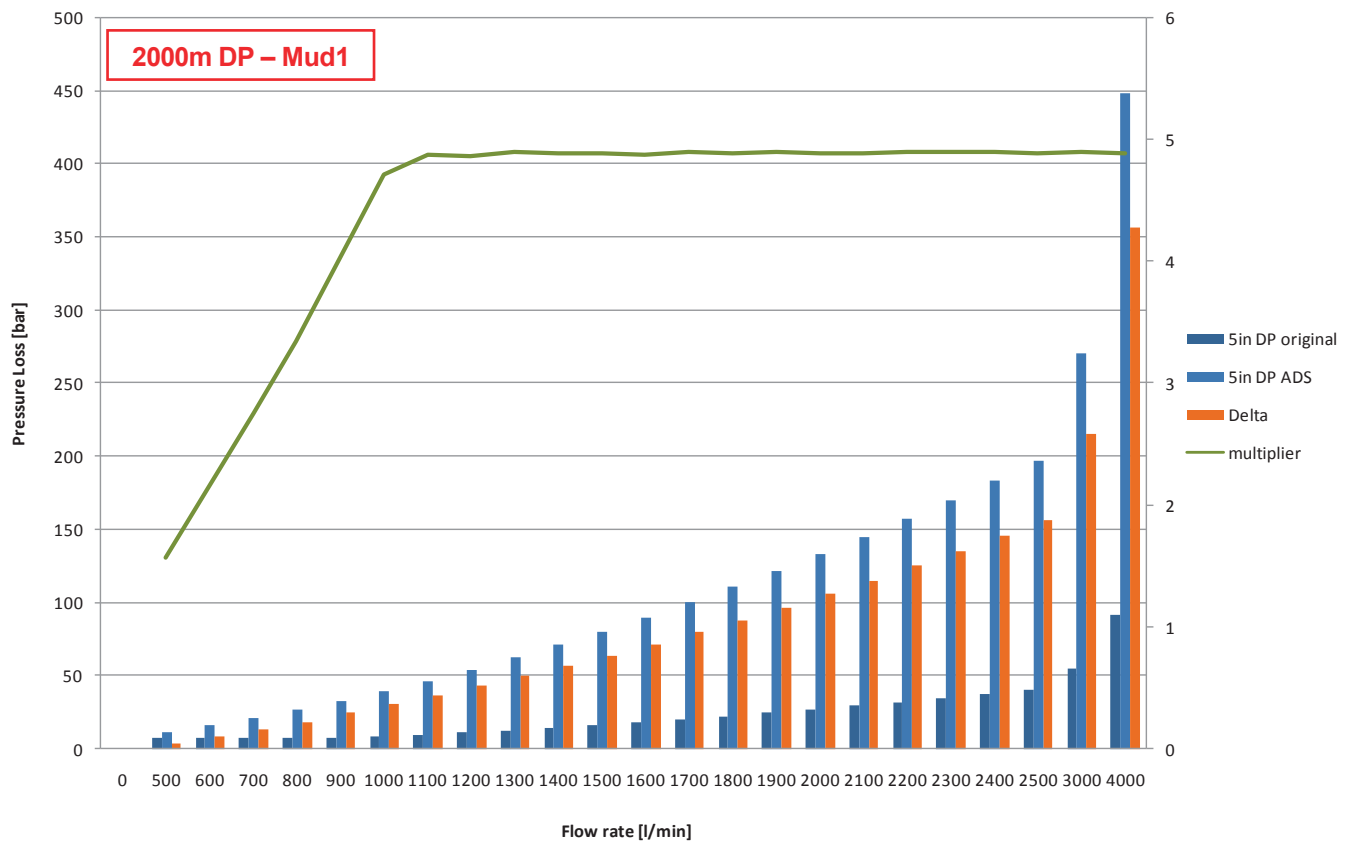
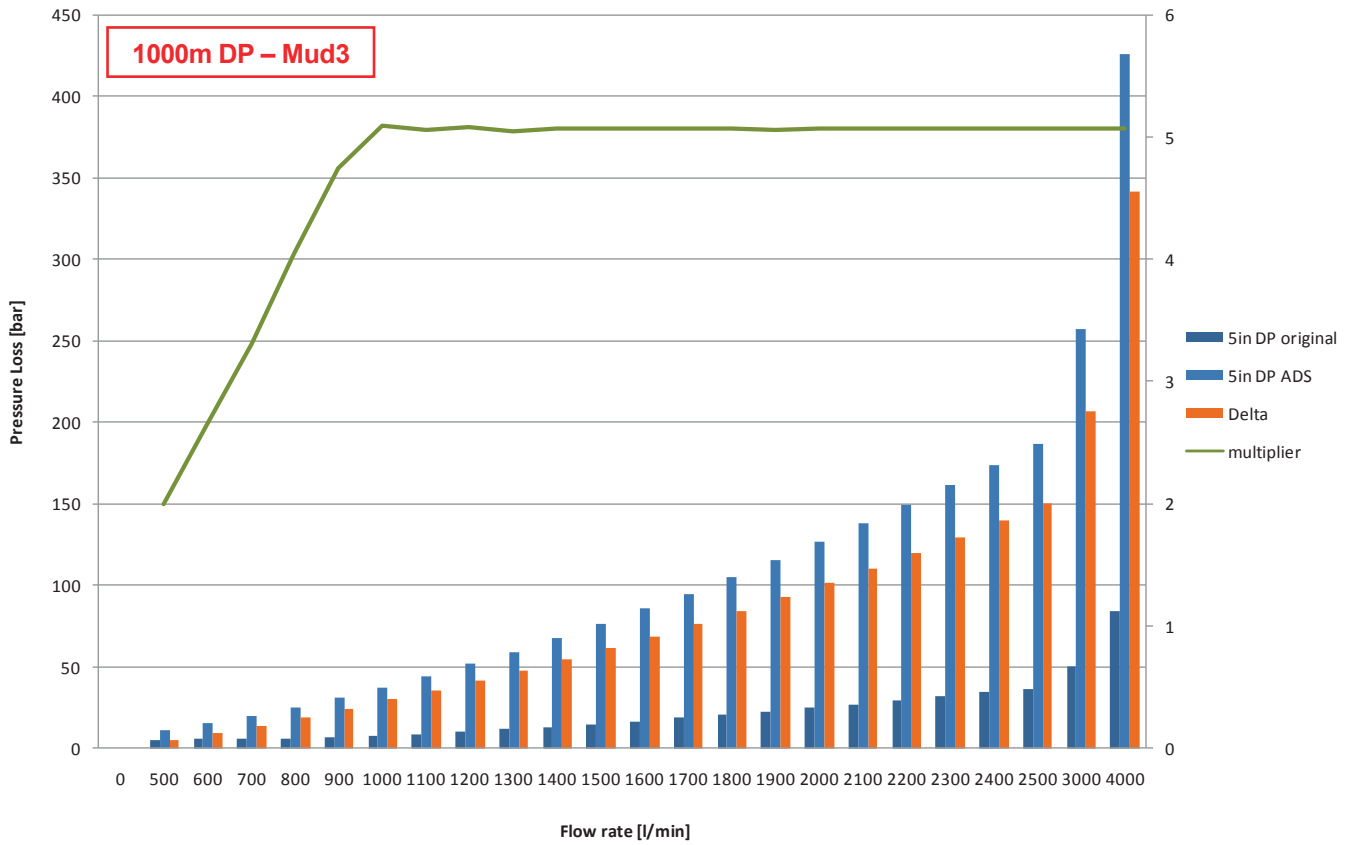

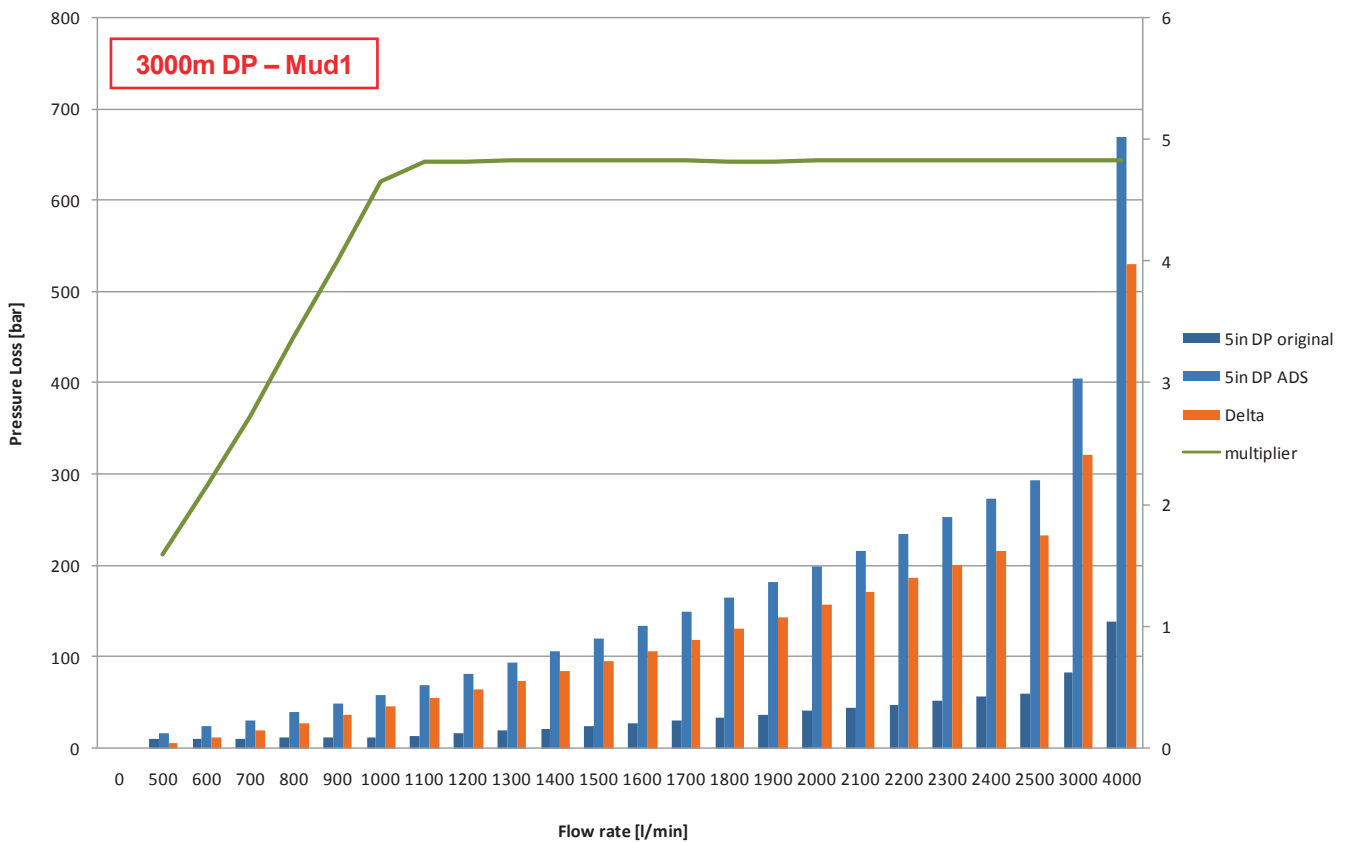
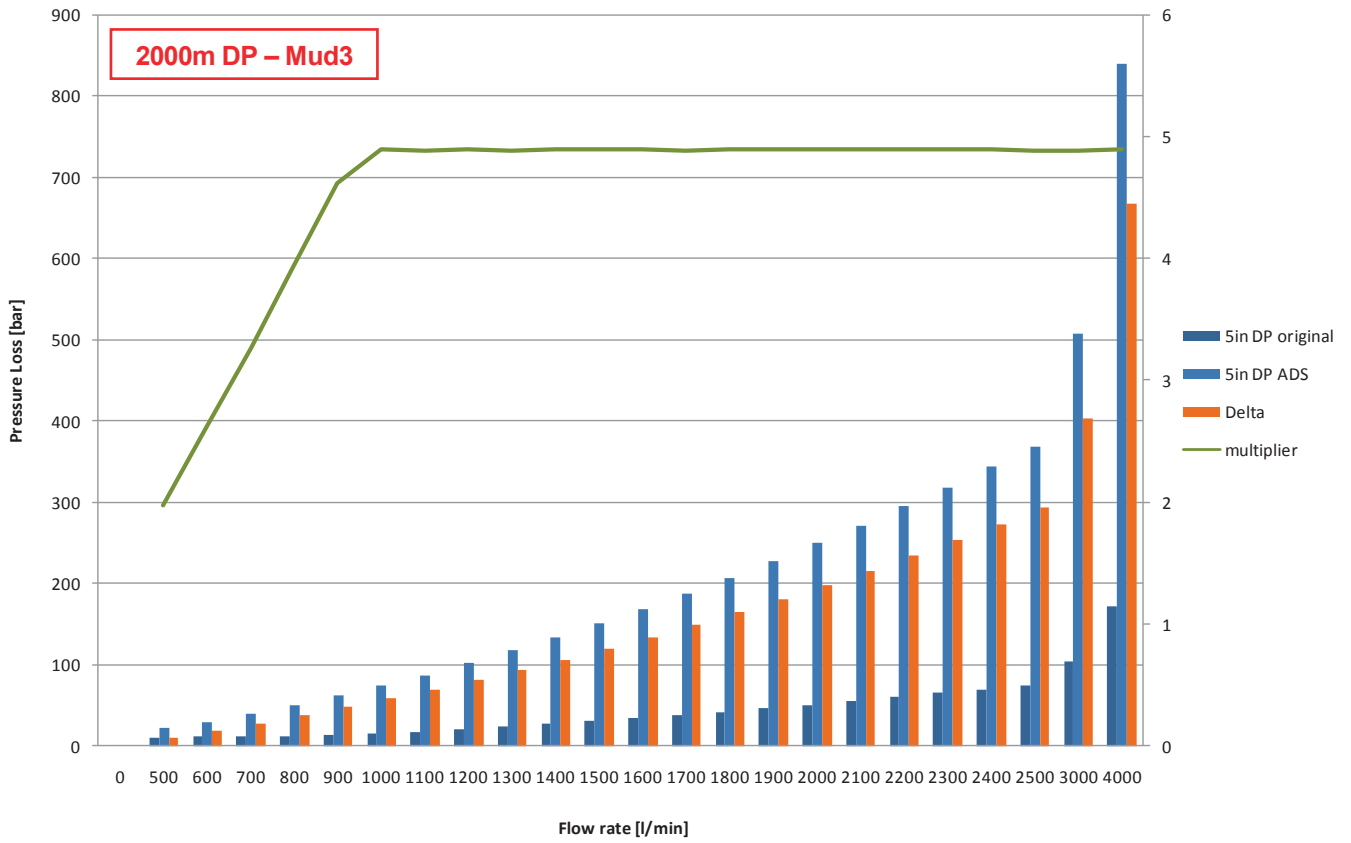

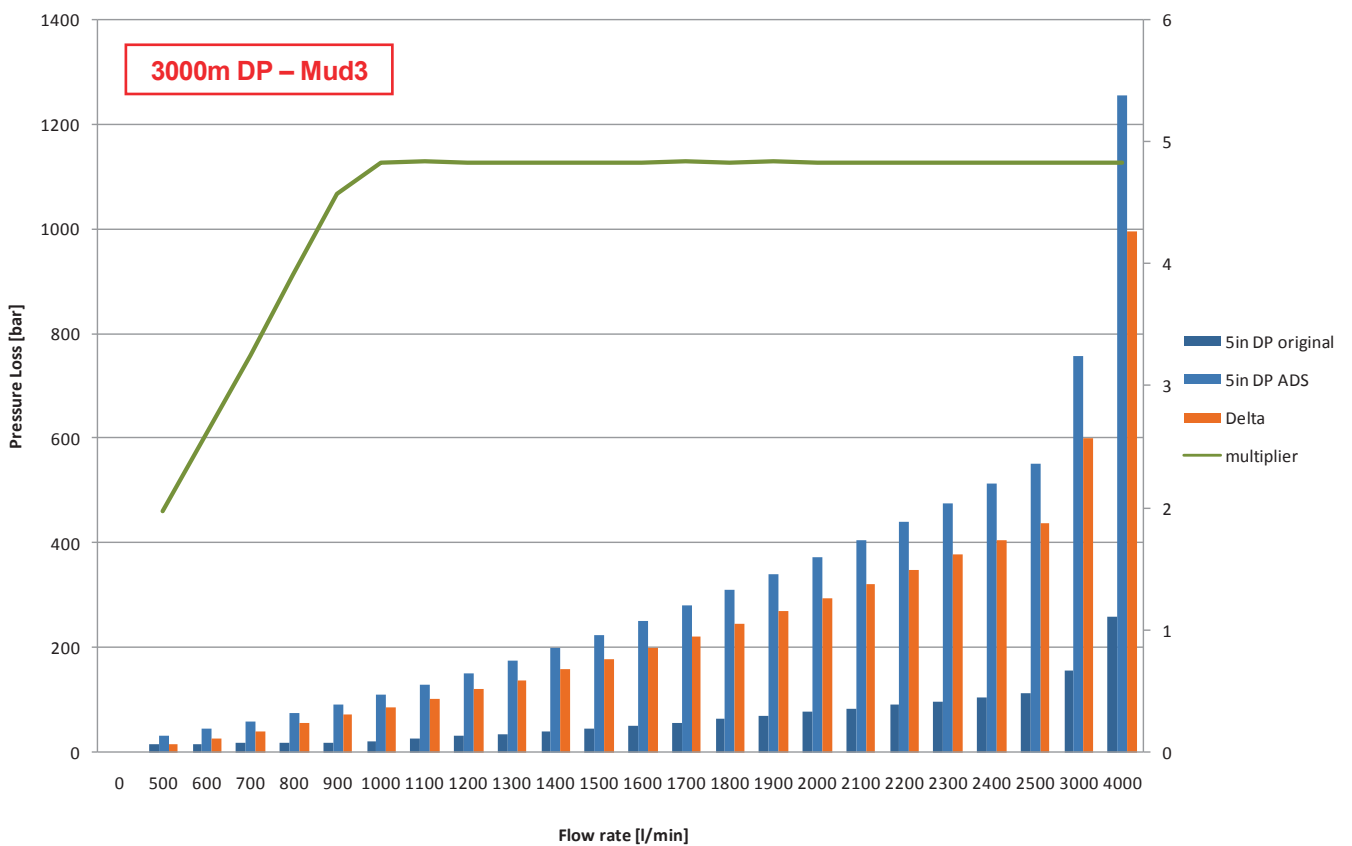
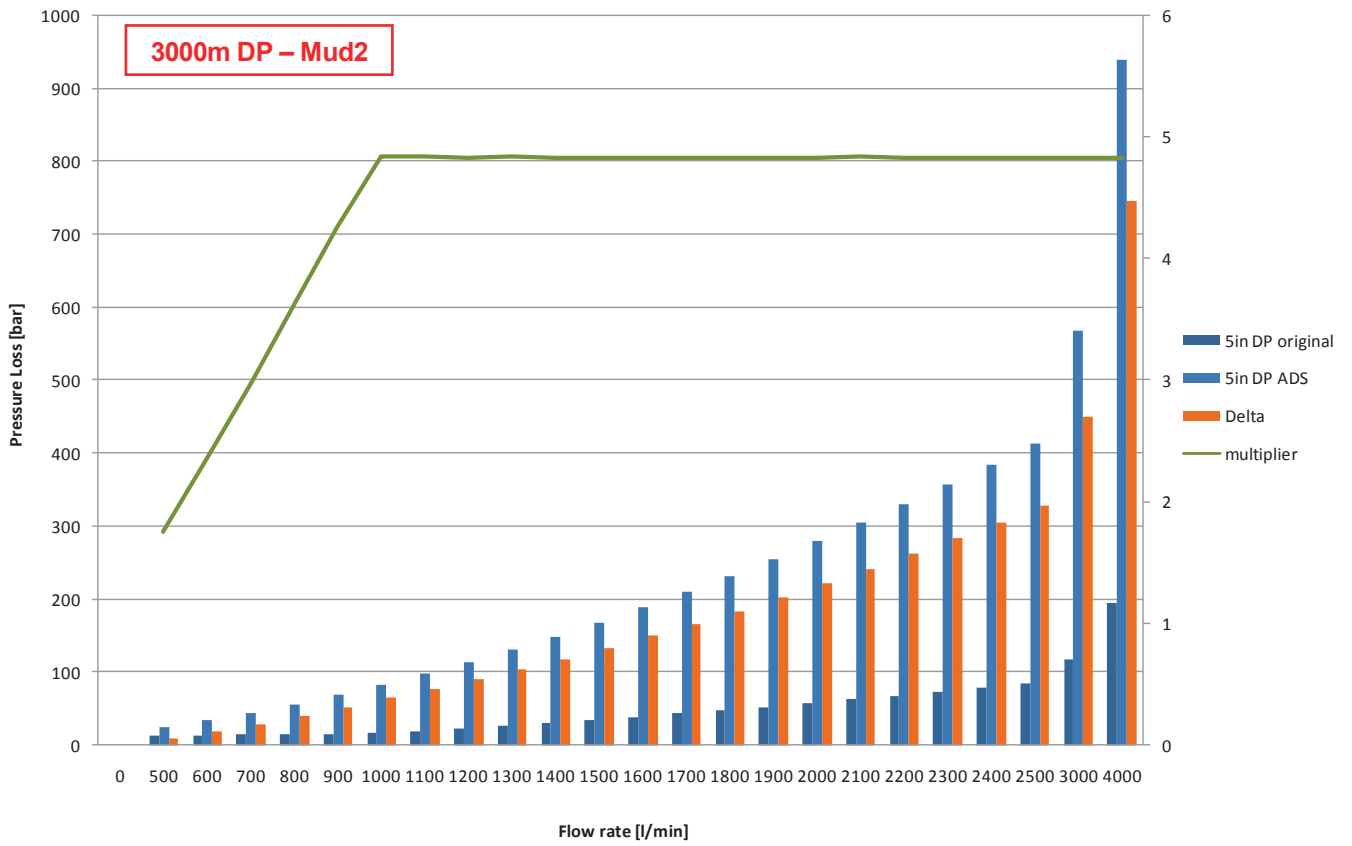

Appendix B – Blueprints

Remarks on Drawings

- All detail drawings are provided as pdf-file on the enclosed CD (filename is equal the partnumber in the assembly drawing)
- The explosion and detail drawings are in German because of manufacturing the parts at companies in Austria
- Due to print-out of the thesis the scale is altered

Für diese Zeichnung wird jeglicher Rechtsschutz in Anspruch genommen. Sie darf unerlaubt weder kopiert, vervielfältigt oder Dritten mitgeteilt noch anderweitig mißbraucht werden und bleibt unser Eigentum.

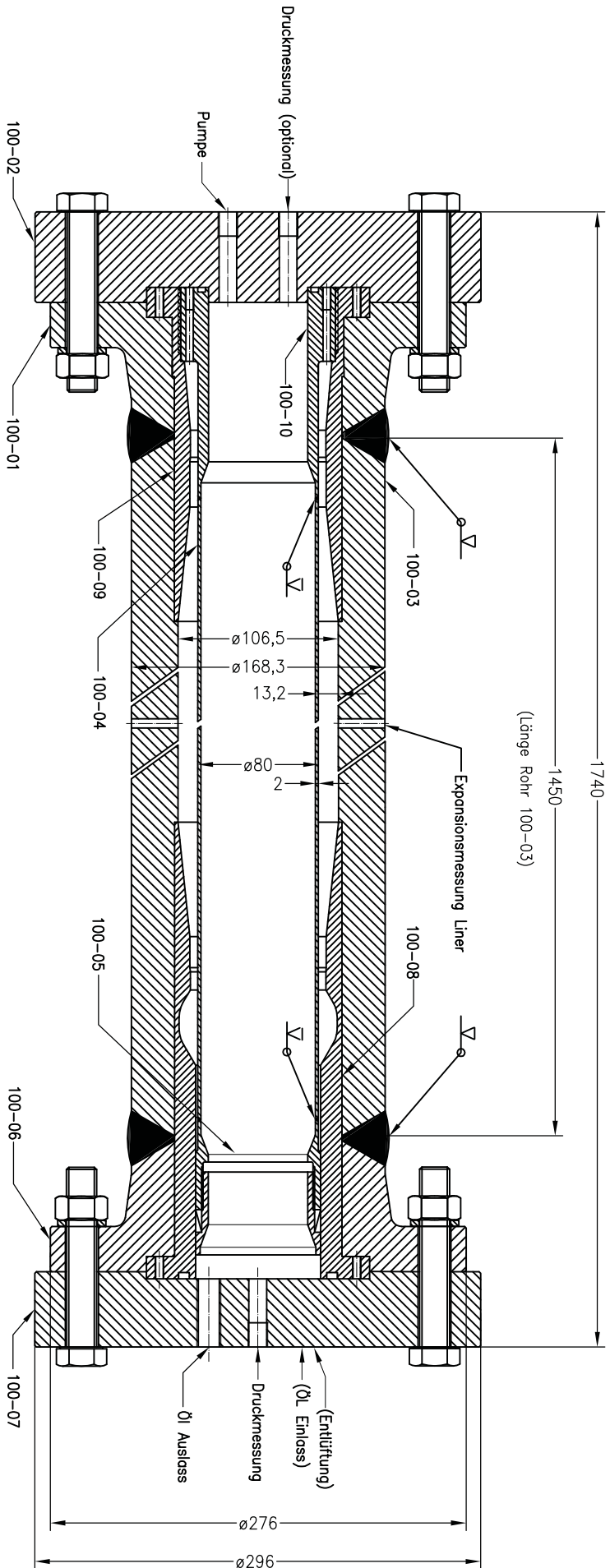

100-05 (Dichtung) gemäß ADS.54.402 Rev A4 (Nut), ADS.54.403 Rev A3 (Pin), ADS.54.404 Rev A3 (Metal Seal), ADS.54.404-01 Rev A3 (Metal Seal - External Ring), ADS.54.404-02 Rev A3 (Metal Seal - Inner Ring)

ENZELTEILE		Datum	Name
100-01.06	Flansch Box - Pin	17.01.12	STEINDLER
100-02.07	Endplatte Box - Pin	Bearb. 15.04.12	STEINDLER
100-03	Drillpipe		
100-04	Inner Liner		
100-05	Dichtung		
100-08	Hülse (Pin)		
100-09	Hülse (Box)		
100-10	Lineransatz		

Maßstab 1:4 (A4)

Liner-Sealing Tester

Zusammenstellung (100)

REV_A.1

Blatt 1/1

Für diese Zeichnung wird jeglicher Rechtsschutz in Anspruch genommen. Sie darf unerlaubt weder kopiert, vervielfältigt oder Dritten mitgeteilt noch anderweitig mißbraucht werden und bleibt unser Eigentum.

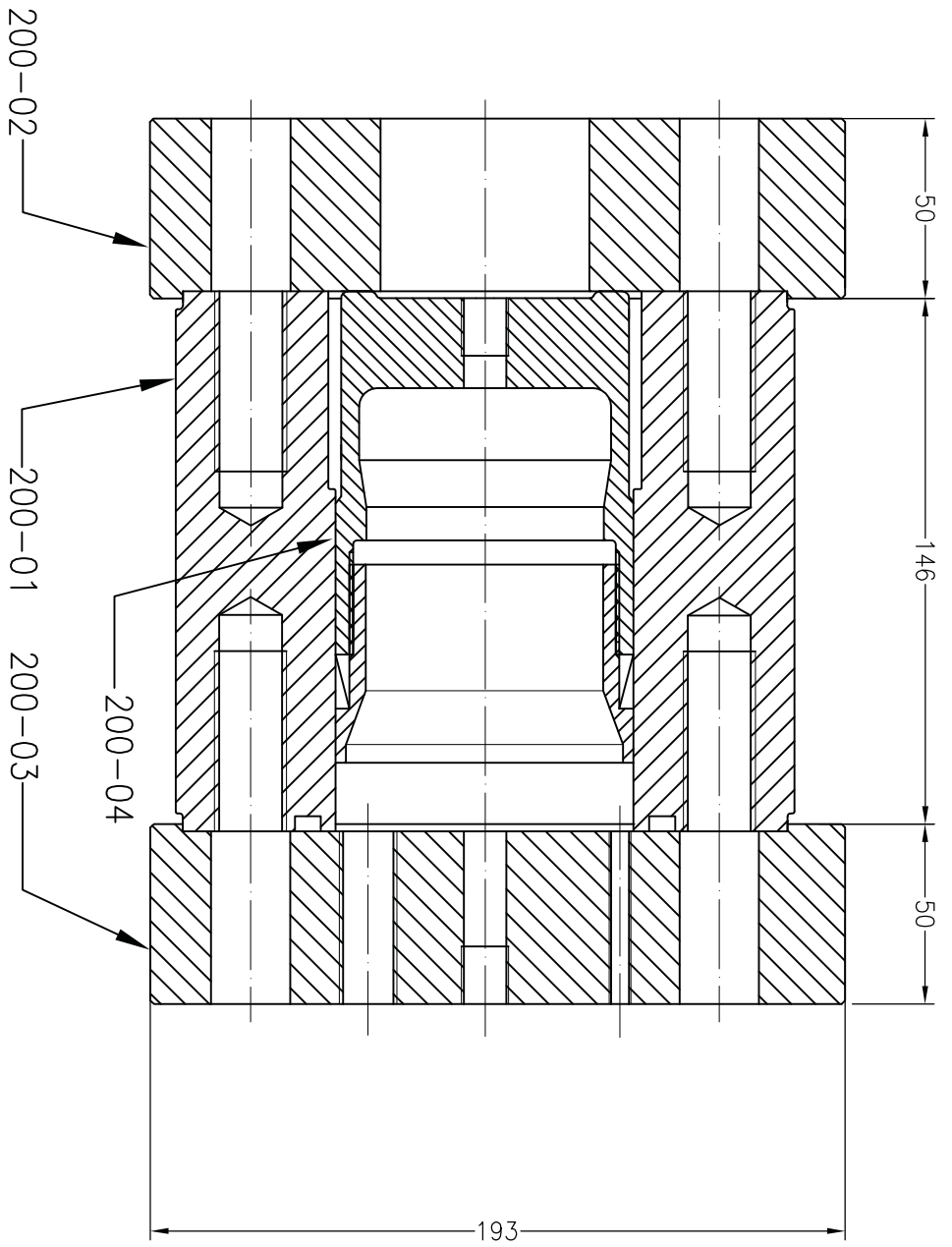

ENZELTEILE		Datum	Name
Nr.	Bezeichnung		
200-01	Rohr	06.02.12	STEINDLER
200-02	Endplatte1	15.04.12	STEINDLER
200-03	Endplatte2		
200-04	Dichtung		

Maßstab 1:2 (A4)

REV_A.1

Sealing-Only Tester

Zusammenstellung (200)

Blatt
1/1

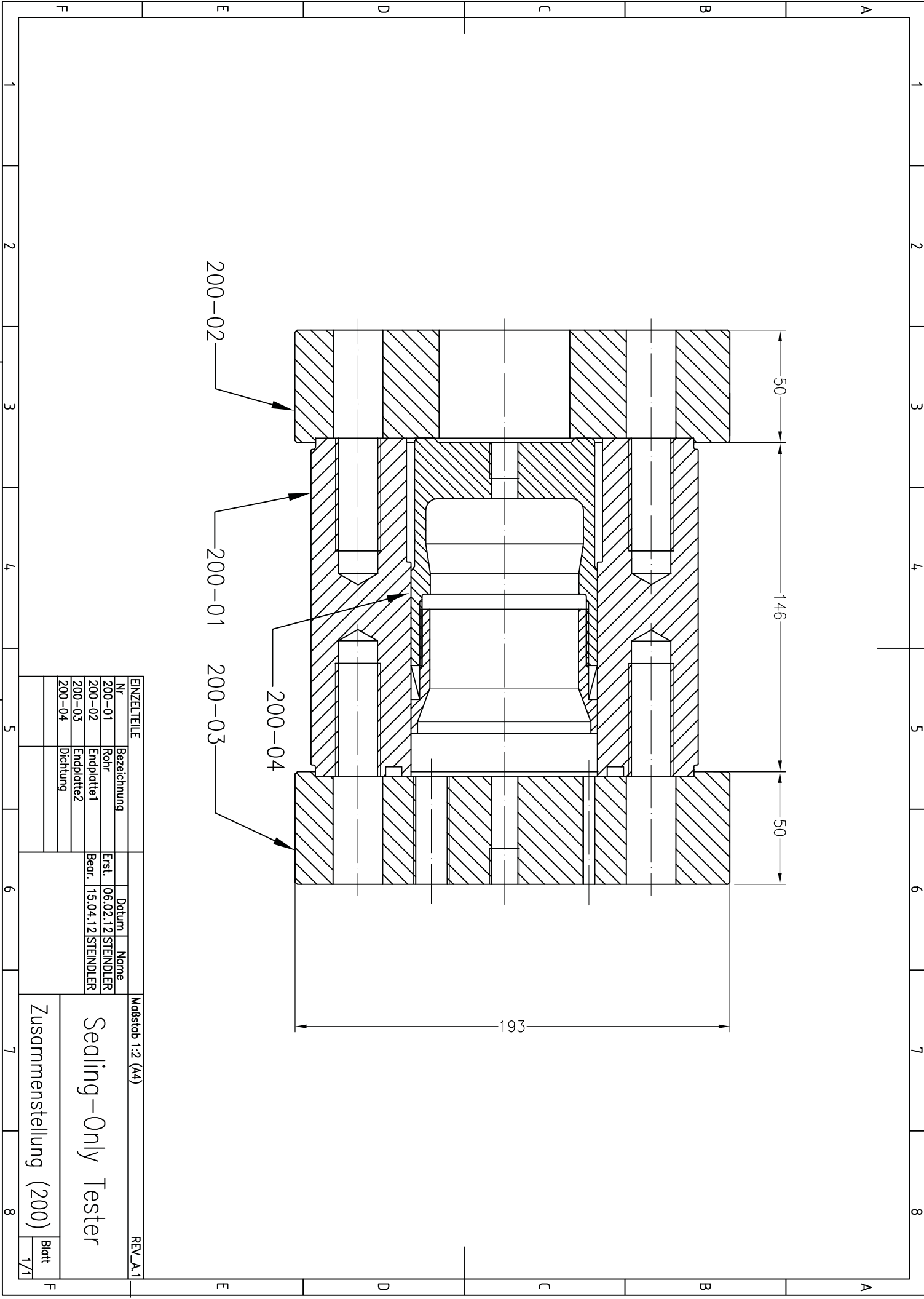

Für diese Zeichnung wird jeglicher Rechtsschutz in Anspruch genommen. Sie darf unerlaubt weder kopiert, vervielfältigt oder Dritten mitgeteilt noch anderweitig mißbraucht werden und bleibt unser Eigentum.

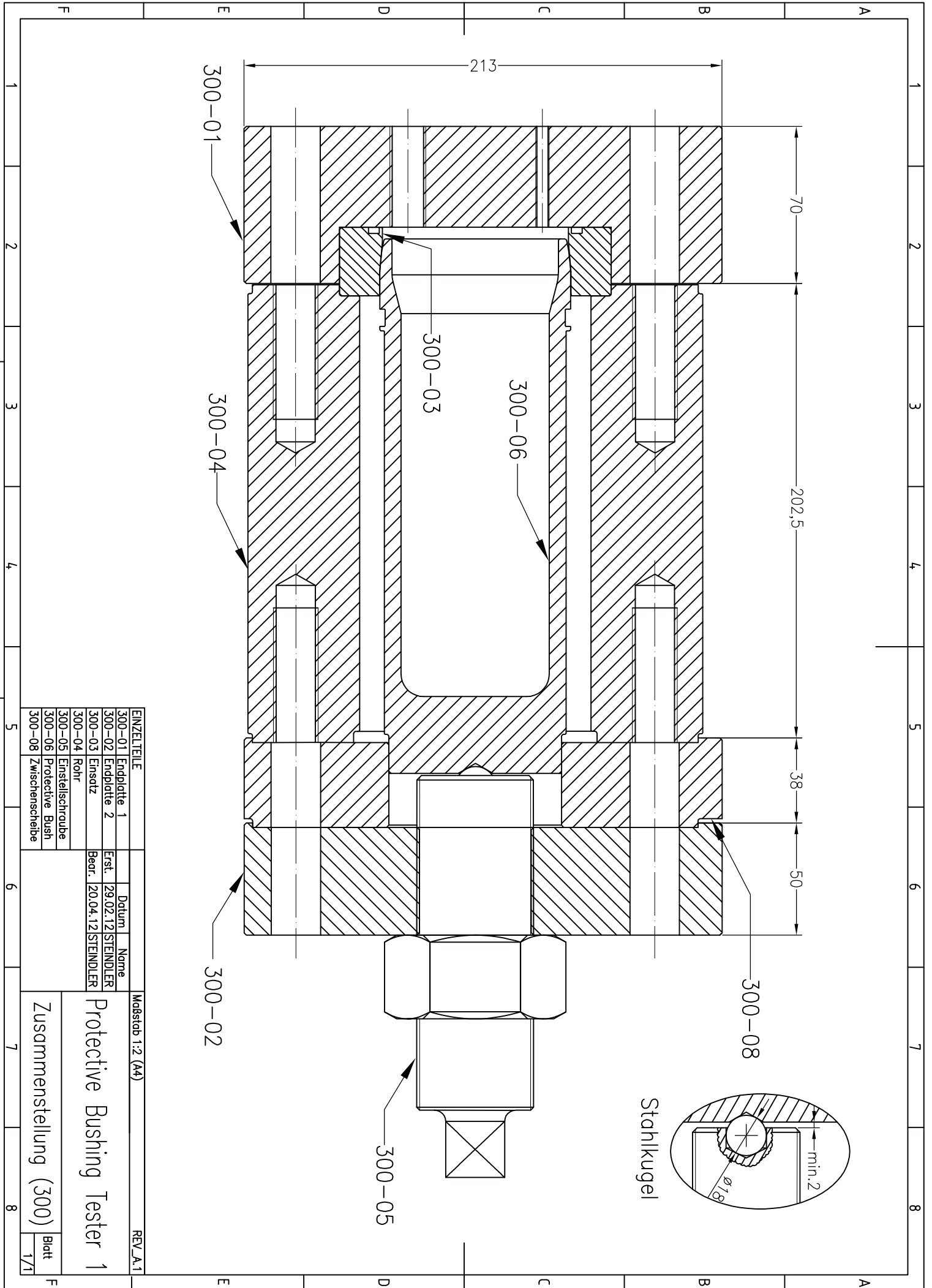

ENZELTEILE		Datum	Name
300-01	Endplatte 1	29.02.12	STEINDLER
300-02	Endplatte 2	Bear.	20.04.12 STEINDLER
300-03	Einsteck		
300-04	Rohr		
300-05	Einsteckschraube		
300-06	Protective Bush		
300-08	Zwischenschleibe		

Maßstab 1:2 (A4)

REV_A.1

Protective Bushing Tester 1

Zusammenstellung (300)

Blatt 1/1

Für diese Zeichnung wird jeglicher Rechtsschutz in Anspruch genommen. Sie darf unerlaubt weder kopiert, vervielfältigt oder Dritten mitgeteilt noch anderweitig mißbraucht werden und bleibt unser Eigentum.

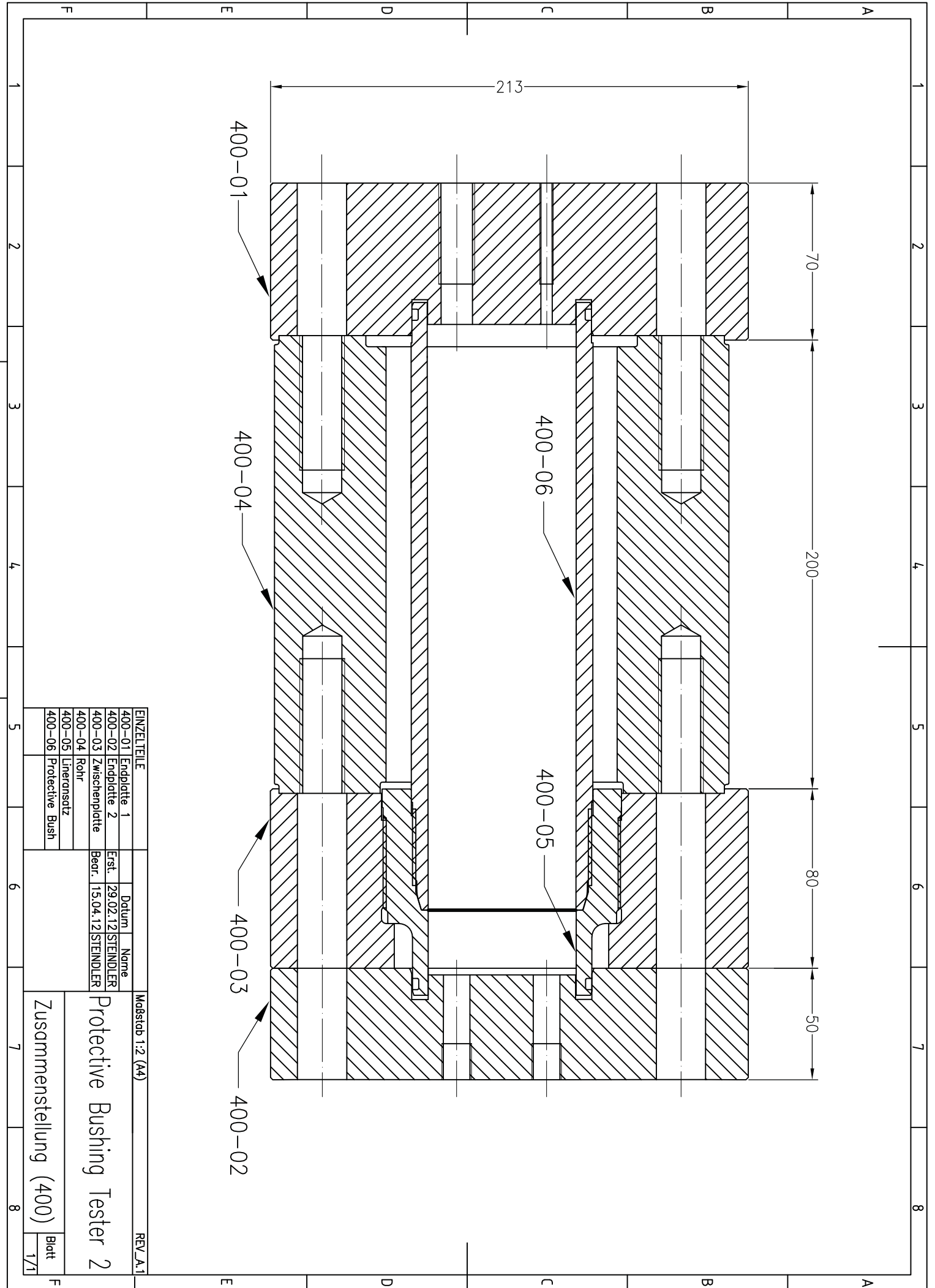

ENZELTEILE		Datum	Name
400-01	Endplatte 1	29.02.12	STEINDLER
400-02	Endplatte 2		
400-03	Zwischenplatte		
400-04	Rohr		
400-05	Linienansatz		
400-06	Protective Bush		

Maßstab 1:2 (A4)
Protective Bushing Tester 2
 Zusammenstellung (400)

REV. A.1
 Blatt 1/1

List of Files Liner&Sealing Tester (100)

Filename (Partnumber.pdf)	Partname
100.pdf	Assembly Drawing
100-01.pdf	Flange-Box
100-01_vorb.pdf	Flange-Box (prepared)
100-02.pdf	End Plate-Box
100-03_1.pdf	Main Pipe (Box)
100-03_2.pdf	Main Pipe (Pin)
100-04.pdf	Inner Liner
ADS.54.402.pdf	Nut (100-05)
ADS.54.403.pdf	Pin (100-05)
ADS.54.404.pdf	Metal Seal (100-05)
ADS.54.404-01.pdf	Metal Seal – External Ring (100-05)
ADS.54.404-02.pdf	Metal Seal – Inner Ring (100-05)
100-06.pdf	Flange-Pin
100-06_vorb.pdf	Flange-Pin (prepared)
100-07.pdf	End Plate-Pin
100-08.pdf	Insert-Pin
100-08_nut.pdf	Groove of Insert Pin
100-09.pdf	Insert-Box
100-10.pdf	Liner Nut
100-10_nut.pdf	Groove of Liner Nut

List of Files Sealing-Only Tester (200)

Filename (Partnumber.pdf)	Partname
200.pdf	Assembly Drawing
200-01.pdf	Main Pipe
200-01_nut.pdf	Groove of Main Pipe
200-02.pdf	End Plate 1
200-03.pdf	End Plate 2
200-4.pdf	Modified Nut

List of Files Protective Bushing Tester 1 (300)

Filename (Partnumber.pdf)	Partname
300.pdf	Assembly Drawing
300-01.pdf	End Plate 1
300-02.pdf	End Plate 2
300-03.pdf	Pin Insert
300-03_nut.pdf	Groove Pin Insert
300-04.pdf	Main Pipe
300-05.pdf	Motion Screw
300-06.pdf	Protective Bushing
300-08.pdf	Middle Plate

List of Files Protective Bushing Tester 2 (400)

Filename (Partnumber.pdf)	Partname
400.pdf	Assembly Drawing
400-01.pdf	End Plate 1
400-02.pdf	End Plate 2
400-03.pdf	Middle Plate
400-04.pdf	Main Pipe
400-05.pdf	Liner Nut
400-05_nut.pdf	Groove of Liner Nut
400-06.pdf	Protective Bushing
400-06_nut.pdf	Groove of Protective Bushing

List of Files Mounting- and Installation Tools

Filename (Partnumber.pdf)	Partname
100-09_mh.pdf	Mounting Tool for Part 100-09
100-10_mh.pdf	Mounting Tool for Part 100-10
200-04_zs.pdf	Cone Wrench for Part 200-04
400-05_mh.pdf	Mounting Tool for Part 400-05
lever-con.pdf	Elongation for Torque Wrench
lever-sq.pdf	Elongation for Torque Wrench
ADS.Switch.01.000.pdf	Switch for Metal Seal Rings
ADS.Switch.01.001.pdf	Switch for Metal Seal Rings
ADS.Switch.01.002.pdf	Mandrel
ADS.Switch.01.003.pdf	Stud-bolt

Appendix C – Part- and Material Lists

- **Liner&Sealing Tester (100)**
- **Sealing-Only Tester (200)**
- **Protective Bushing Tester 1 (300)**
- **Protective Bushing Tester 2 (400)**

Appendix D – Budget Plan

- **General Cost Estimate**
- **Costs Actual vs. Planned**
- **Manufacturing Costs**

Remarks on Cost Planning

- All hydraulic parts were purchased at Reinprecht company
- Cover for tester was modified after cost planning (only one Plexiglas plate at top)
- Manufacturing costs for liner sealing group (nut, pin, metal rings) is covered in prototype pipe system manufacturing cost plan
- Component 300-08 and torque wrench not in cost plan
- Small parts incl. screws, funnels, tools, paint, ring impact wrench, lifting slings, copper washer...

Cost Planning- Inner Pressure Test Bed						
Description	Quantity of Units	Unit	Price per Unit	Total Price	Supplier	Remarks
Material with ODXlength		[pcs, m, l..]	[€ per pc, m, l..]	[€]		Usage/ Div.
the marked costs are estimated!!!						
Test Bed (Design "Long" 100 - Liner&Sealing)						
Pipe E355 88,9x14,2	1	m	93,60	93,60	RohrWertl	Liner Sealing
Pipe E470 85x12,5	1	m	87,60	87,60	RohrWertl	Liner Sealing
Roundsteel V320 RD 90x73	1	pcs	19,20	19,20	Frankstahl	Liner Sealing Alternative
Roundsteel V320 RD 90x70	5	pcs	19,20	96,00	Frankstahl	Liner Sealing Alternative
Roundsteel RD 90x2000	0,25	pcs	253,20	63,30	Frankstahl	Metall Rings Liner Sealing
Pipe E355 168,3x30	1,45	m	288,00	417,60	RohrWertl	Outer Pip
Pipe E235 80x2	18	m	19,56	352,08	RohrWertl	Inner Liner
Pipe E470 150x32,5	0,24	m	372,00	89,28	RohrWertl	Contour Box-End
Pipe E470 150x35	0,32	m	396,00	126,72	RohrWertl	Contour Pin-Fnd
Pipe E355 114x28	2	m	178,80	357,60	RohrWertl	Linerut
Pipe E470 110x25	2	m	162,00	324,00	RohrWertl	Alternative Linerut
Autogenouscut E355 285x90 (ID 95)	2	pcs	92,72	185,44	TechnoStahl	Flange
Roundsteel V320 300x50	1	pcs	66,00	66,00	Frankstahl	Endplate Pin-End
Roundsteel V320 300x60	1	pcs	78,00	78,00	Frankstahl	Endplate Box-Fnd
Hexagonal Screw M20x120 10.9	16	pcs	8,19	131,04	Wegertseder	Connecting Endplate-Flange
Nut M20 10	16	pcs	1,24	19,84	Wegertseder	Connecting Endplate-Flange
Washer 37x4	32	pcs	0,26	8,32	Wegertseder	Connecting Endplate-Flange
O-Ring PU 73x3,55	5	pcs	14,30	71,50	Plastoseal	Connecting Endplate-Flange
O-Ring PU 95x5,3	5	pcs	18,85	94,25	Plastoseal	Connecting Endplate-Flange
Hexagonal Screw M6x40 10.9	1	pcs	2,23	2,23	Wegertseder	Locking Screw
Hexagonal Screw M16x40 10.9	2	pcs	2,46	4,92	Wegertseder	Locking Screw
Allen Screw M6x40	4	pcs	1,47	5,88	Wegertseder	Locking Screw
Ring Screw M6x100	4	pcs	1,50	6,00	Hornbach	Removal Liner
Glue Conductor Line	7,2	m	3,00	21,60	Stankovsky Industrie	Fixation of Conductor Line on Inner Liner
Cylindrical Pin 6x60	8	pcs	0,94	7,52	Wegertseder	Extension Measurement Liner
Manometer up to 1000bar	1	pcs	38,20	38,20	hytec-hydraulik	Manometer only up to 600bar available
High Pressure Tube NP 700bar	1	m	177,12	177,12	Berger-Koppel	Pressure Test over Time
High Pressure Ball Valve NP 700bar	1	pcs	181,80	181,80	Berger-Koppel	Pressure Test over Time
Costs Welding	1	total	500,00	500,00	0	Connecting Liner, Outer Pipe
Manufacturing Costs Steel	1	total	600,00	600,00	0	ADSno CNC, Lathe only up to OD 250
Hydraulic Oil HLP 46	2	Sl	30,00	60,00	Lagerhaus	Pressurizing Liner
Subtotal				4286,64		
Test Bed (Design "Short" 200 - Sealing-Only)						

Hexagonal Screw M6x60 8.8	4	pcs	0,50	2,00	Hornbach	Connecting Insert-Flange
Nut M48x3 8 (Fine threaded)	1	pcs	18,72	18,72	Wegertseeder	Compression Force Motion Screw
Roundsteel V320 RD 55x500	1	pcs	36,00	36,00	Frankstahl	Compression Force Motion Screw
Roundsteel V320 RD 230x75	2	pcs	82,80	165,60	Frankstahl	Flange
Roundsteel V320 RD 230x55	2	pcs	62,40	124,80	Frankstahl	Flange
Roundsteel V320 RD 230x85	1	pcs	93,60	93,60	Frankstahl	Flange
Autogenouscut E355 RD 125x35 (ID 70)	5	pcs	16,80	84,00	TechnoStahl	Insert (simulates Pin)
O-Ring PU 88x3,55	5	pcs	19,00	95,00	Plastoseal	Connecting Insert-Flange
O-Ring PU 73x3,55	6	pcs	14,30	85,80	Plastoseal	Connecting Flange-Pipe
Subtotal				1062,78		
GFK-Tester						
Roundsteel V320 RD 180x45	3	pcs	43,20	129,60	Frankstahl	Endplate
O-Ring PU 95x5,3	4	pcs	18,85	75,40	Plastoseal	Connecting Plates
Subtotal				205,00		
Total Costs				7245,02		Sum
+10-15% (Packaging, Transportation, Minor Parts usw.)				896,59		Also depending on running the tests
				8332		

INNER PRESSURE TEST BED									
Costs Actual vs Planned									
		24.07.2012							
Costs Planned	Costs Actual	Purchasing Costs	Cost Saving	Manufacturing Costs	Total Costs				
Liner&Sealing Tester (100)	4286,64	2780,79	0,00	1505,85	3032,70	266,00	266,00	Kremsmüller	
Sealing Tester (200)	562,06	490,75	0,00	71,31	0,00	299,25	299,25	Kremsmüller	
Protective Bushing Tester (300&400)	1066,98	983,42	0,00	83,56	1238,80	166,25	166,25	Kremsmüller	
GFK Tester	205,00	205,00	0,00	0,00	0,00	133,00	133,00	Kremsmüller	
Bench with cover	675,95	666,25	0,00	9,70	0,00	633,00	633,00	MBW Werderit	
Hoisting Equipment	185,00	50,00	35,00	100,00	0,00	266,00	266,00	Kremsmüller	
Delivery Costs	267,59	227,34	0,00	40,25	0,00	299,25	299,25	Kremsmüller	
Small Parts, Transportation, Packaging	896,59	202,82	338,38	355,39	0,00	221,35	221,35	Indes Tech	
Total	8146	5606,37	373,38	2166,06	4271,50	114,00	108,3	Indes Tech	
Summary Manufacturing Costs									
Tester	Partnumber	Description	Quantity	Unit Costs	Discount (5%)	Costs	Manufacturer		
Liner&Sealing Tester (100)	100-01	Flange-Box	1	280,00		266,00	Kremsmüller		
	100-02	Endplate-Box	1	315,00		299,25	Kremsmüller		
	100-03 preparation	Pipe	1	175,00		166,25	Kremsmüller		
	100-03	Pipe	1	140,00		133,00	Kremsmüller		
	100-03 welding	Pipe	1	633,00		633,00	MBW Werderit		
	100-04	Inner Liner	2	140,00		266,00	Kremsmüller		
	100-06	Flange-Pin	1	280,00		266,00	Kremsmüller		
	100-07	Endplate-Pin	1	315,00		299,25	Kremsmüller		
	100-08	Insert-Pin	1	268,00		254,6	Indes Tech		
	100-09	Insert-Box	1	233,00		221,35	Indes Tech		
	100-10	Linernut	2	120,00		228,00	Indes Tech		
Total- 100						3032,70			
Sealing-Only Tester (200)	200-01	Pipe	1	0,00		0,00	ADS		
	200-02	Endplate 1	1	0,00		0,00	ADS		
	200-03	Endplate 2	1	0,00		0,00	ADS		
	200-04	Sealing Nut	1	0,00		0,00	ADS		
Total- 200						0,00			
Protective Bushing Tester1 (300)	300-01	Endplate 1	1	0,00		0,00	ADS		
	300-02	Endplate 2	1	0,00		0,00	ADS		
	300-03	Insert	3	90,00		85,5	Indes Tech		
	300-04	Pipe	1	0,00		0,00	ADS		
	300-05	Motion Screw	1	0,00		0,00	ADS		
	300-06	Protective Bushing	2	157,00		149,15	Indes Tech		
	300-08	Middleplate	1	0,00		0,00	ADS		
Protective Bushing Tester2 (400)	400-01	Endplate 1	1	0,00		0,00	ADS		
	400-02	Endplate 2	1	0,00		0,00	ADS		
	400-03	Middleplate	1	0,00		0,00	ADS		
	400-05	Linerut	1	140,00		133,00	Indes Tech		
	400-05 prepared	Linerut	2	104,00		98,8	Indes Tech		
	400-06	Protective Bushing	1	144,00		136,8	Indes Tech		
	400-06 prepared	Protective Bushing	2	114,00		108,3	Indes Tech		
Total 300&400						1238,80			
Total 100, 200, 300, 400						4271,50			