

University of Leoben

Mechanical Engineering

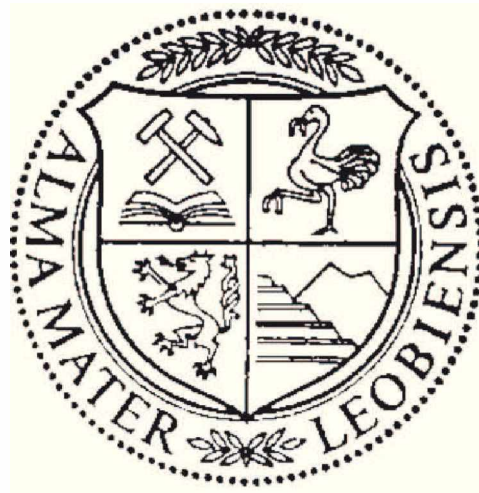

Diploma thesis

at the

Department Product Engineering

Chair for Conveying Technology and Design Methods

In cooperation with the Sandvik Company

New continuous mining system for hard rock application

von

Peter Zeitlhofer

April 2007



Declaration

I hereby declare, that the thesis “New continuous mining system for hard rock application” was produced by myself and by use of the specified literature only.

Leoben, 24.04.2007

Peter Zeitlhofer



I like to thank you:

Univ. Prof. DI. Dr. mont. Franz Kessler
Head of the chair for Conveying Technology and Design Methods

DI. Dr. mont. Stefan Wirth
Chair for Conveying Technology and Design Methods

DI. Dr. mont. MBA Helmut Oberrisser
Commercial director at Sandvik

DI. Andreas Wieczorek
Technical director at Sandvik

Danksagung

An dieser Stelle möchte ich mich bei meinen Eltern, Ing. Edmund und Karin Zeitlhofer, für die Ermöglichung und Finanzierung meines Studiums in Leoben herzlich bedanken.

Ganz speziell möchte ich mich bei meiner Mutter für all die unzähligen, aufbauenden Telefonate während meiner Studienzeit, und speziell während der Erstellung dieser Diplomarbeit, bedanken.

Danke

Table of contents

Declaration	2
Danksagung	4
1. Introduction	13
2. Objective	15
3. Fundamentals of conventional mining systems in open-pit mines	16
3.1. Components used in open-pit mines	18
3.1.1. Drill and Blast (Surface Drill)	18
3.1.2. Shovel excavator	19
3.1.3. Truck	20
3.1.4. Bucket Wheel Excavator	21
3.1.5. Belt wagon	24
3.1.6. Crusher	26
3.1.6.1. Stationary Crusher	26
3.1.6.2. Semi-mobile Crusher	27
3.1.6.3. Mobile crusher	28
3.1.7. Conveyor	31
3.1.8. Spreader	32
3.1.9. Storage area	35

3.1.9.1. Design of storage areas	38
3.2. Mining Methods	40
3.2.1. Continuous mining and haulage	40
3.2.1.1. Flow diagram for “Continuous mining and haulage”	40
3.2.1.2. Example of implementation (Köflach/Austria)	41
3.2.2. Truck and Shovel	44
3.2.2.1. Flow diagram for “Truck and Shovel”	44
3.2.2.2. Example of implementation (Kaltim Prima Coal Mine/Indonesia)	45
3.2.3. Truck, Shovel and Conveyor	50
3.2.3.1. Flow diagram for “Truck, Shovel and Conveyor”	51
3.2.3.2. Example for implementation (Mae Moh/Thailand)	52
3.3. Advantages and disadvantages of the conventional mining systems	57
3.3.1. Comparison of the advantages and disadvantages of the 3 main methods	58
4. New continuous mining system for hard rock application	61
4.1. Executive summary	61
4.2. General layout	66
4.3. Flow diagram	67
4.4. Mining Concept	68
5. Dump operation	92

5.1. Dump Area	92
5.1.1. Equipment of spreading system for dumping	92
5.1.2. Dumping Schedule	94
5.1.3. Dumping Concept	96
5.1.4. Dump Area	102
5.2. Equipment description	109
5.2.1. Drilling equipment	109
5.2.2. Loading	110
5.2.3. Crushing system	113
5.2.4. Equipment of mine conveyor system	115
6. Comparison of the operating costs	118
7. Conclusion	131
8. Literature index	132

List of figures

Fig. 3-1: Description of the conventional systems for open-pit mining.....	17
Fig. 3-2: Surface drilling unit Type 1190 by Sandvik.....	18
Fig. 3-3: Shovel excavator Type 4100 XPB by P&H.....	19
Fig. 3-4: Haulage truck.....	20
Fig. 3-5: Bucket wheel excavator Type VABE 1500 in Monticello/USA	21
Fig. 3-6: Main components of a BWE.....	22
Fig. 3-7: Belt wagon Type VABW 1800/ 31+36 in Neygeli/India	24
Fig. 3-8: Main components of a BW.....	25
Fig. 3-9: In-pit crusher at MRN in Brazil.....	26
Fig. 3-10: MMD Semi-mobile Sizer at Lignitos de Meirama/Spain	27
Fig. 3-11: Mobile crusher with pneumatic tyres.....	29
Fig. 3-12: Mobile crusher with crawlers	30
Fig. 3-13: Belt conveyor Type VABC 1600 in Tantalos/Mexico	31
Fig. 3-14: Spreader Type VASP 2200 in Mae Moh/Thailand	32
Fig. 3-15: Main components of a Spreader.....	33
Fig. 3-16: Storage area for copper ore in Chuquicamata/Chile	35
Fig. 3-17: Rectangular and circular parted storage area	36
Fig. 3-18: Maximum height of a storage area for flammable material	37

Fig. 3-19: Storage area – chevron	38
Fig. 3-20: Storage area – windrow	39
Fig. 3-21: Storage area – cone shell.....	39
Fig. 3-22: Flow diagram for "Continuous mining and haulage"	40
Fig. 3-23: Bucket wheel excavator Type VABE 700 in Köflach/Austria	41
Fig. 3-24: Beltwagon Type VABW 1400 in Köflach / Austria	42
Fig. 3-25: Spreader Type VASP 1600/20+30 in Köflach/Austria	43
Fig. 3-26: Flow diagram for "Truck and Shovel"	44
Fig. 3-27: Open-pit coal mine in Kalimantan/Indonesia	45
Fig. 3-28: Hydraulic shovel excavator Caterpillar Type 320B	46
Fig. 3-29: Hydraulic shovel excavators Liebherr Type R996 loading trucks in the pit.....	47
Fig. 3-30: Haulage trucks transport the material out of the mine to the crushing unit.....	47
Fig. 3-31: Spreader with 2 separate stockpiles	48
Fig. 3-32: Overland conveyor for ship onloading.....	49
Fig. 3-33: Flow diagram for "Truck, Shovel and Conveyor"	51
Fig. 3-34: Mine layout with mining and dumping area.....	53
Fig. 3-35: Hydraulic excavator Hitachi EX2500E loading a truck Euclid-Hitachi EH1700	54
Fig. 3-36: MMD Semi mobile crushing unit	55

Fig. 3–37: Belt conveyor system VABCS 1800 in mine	55
Fig. 3–38: Spreader Type VASP 2000/50+50 with Tripper car Type VATR 1800	56
Fig. 3–39: Comparison of the advantages and disadvantages of the 3 main methods of open-pit mining.....	59
Fig. 4–1: General mining plan for the next 35 years	62
Fig. 4–2: General plant layout	66
Fig. 4–3: Flow diagram for "New continuous mining system for hard rock application in Aktogai / Kazakhstan"	67
Fig. 4–4: Mine production schedule – information from KCC.....	69
Fig. 4–5: Aktogai – General plant layout 1	70
Fig. 4–6: Aktogai – Mine bench – Stage 1	73
Fig. 4–7: Aktogai – Mine bench – Stage 2	75
Fig. 4–8: Aktogai – Mine bench – Stage 3	76
Fig. 4–9: Aktogai – Mine bench – Stage 4	77
Fig. 4–10: Aktogai – Mine bench – Stage 5	78
Fig. 4–11: Aktogai – Mine bench – Stage 6	79
Fig. 4–12: Aktogai – Mine bench – Stage 7	80
Fig. 4–13: Aktogai – Mine bench – Stage 8	81
Fig. 4–14: Aktogai – Mine bench – Stage 9	83
Fig. 4–15: Aktogai – Mine bench – Stage 10	84

Fig. 4-16: Aktogai – Mine bench – Stage 11	86
Fig. 4-17: Aktogai – Mine bench – Stage 12	87
Fig. 4-18: Aktogai – Mine bench – Stage 13	89
Fig. 4-19: Aktogai – Mine bench – Stage 14	90
Fig. 5-1: Aktogai– Dump Area A – Spreader Operation from BC – D2A/B	95
Fig. 5-2: Aktogai – Dump Area A – Cross Section.....	97
Fig. 5-3: Aktogai – Dump Area B – Cross Section.....	98
Fig. 5-4: Aktogai – Dump yard in year 1	100
Fig. 5-5: Aktogai – Dump yard in year 2	101
Fig. 5-6: Aktogai – Dump yard in year 3 to 32	103
Fig. 5-7: Aktogai – Layout of conveyors at the beginning	105
Fig. 5-8: Aktogai – Layout of Dump Area at 1st phase	106
Fig. 5-9: Sandvik surface drilling rig Type 1190E	110
Fig. 5-10: Rope shovel excavator P&H 4100 XPB	111
Fig. 5-11: Wheel loader LeTourneou L-2350	112
Fig. 5-12: Inlet port of the fully mobile crusher by MMD Type 1500	113
Fig. 5-13: MMD mobile crusher plant Type 1500.....	114
Fig. 6-1: Comparison of the operating costs of the 4 examples of continuous and discontinuous conveying methods	129

Fig. 6-2: Diagram of the comparison of the 4 examples of continuous and discontinuous conveying methods 129



1. Introduction

Nowadays, there are three conventional mining systems regarded to be state of the art for open-pit mining. They have different advantages and disadvantages in regard to the used units and equipment related to mining velocity and rock hardness.

The first system called "*Continuous Mining and Haulage*" uses a bucket wheel excavator for mining and a belt conveyor for transporting of the mined material.

The second system named "*Truck and Shovel*" uses a surface drilling rig for loosening the material by introducing explosives into the boreholes. The loose material is handled with a shovel excavator or wheel loader and transported out of the mine by trucks instead of a belt conveyor.

The third system called "*Truck, Shovel and Conveyor*" works very similar to the second system with one exception. The mined material is not transported out of the mine by trucks but it is carried to a crusher inside of the mine directly with a wheel loader or shovel excavator or by use of trucks. After crushing and sizing in the crusher the material it is transported via a belt conveyor out of the mine.

For mining of soft rock, all these three systems can be used. Hard rock mining is only possibly by use of the second and third system.



The aim of this diploma thesis is to develop and describe a “*New continuous mining system*” for hard rock application which can be used for mining hard rock and soft rock. The advantages of all three systems are to be extracted to be used for the “*New continuous mining system*” discussed in this thesis.

2. Objective

The aim of this diploma thesis is to develop and describe a *“New continuous mining system for hard rock application”* and describing the complete material handling process with special look at the copper mine Aktogai in Kazakhstan.

The conveyance of the mined material out of the mine and the used machines and units are of capital importance and have to be described in detail.

The aim of this project is to enhance the operational capacity and reduce the amount of personnel by using belt conveyors instead of trucks.

3. Fundamentals of conventional mining systems in open-pit mines

The aim of mining in an open-pit mine is the extraction of raw materials like coal or copper or any other materials. This can happen either directly or after removing the top soil and overburden.

There are several selection parameters for determining the best system:

- ✓ Material properties
 - Hard rock
 - Soft rock

- ✓ Geology of the planned pit
 - Outline of the deposit
 - Type of overlay
 - Total deposits (tons, m³, ...)

- ✓ Annual output

- ✓ Possible production
 - tons/year

- ✓ environmental influences
 - temperature
 - snow
 - rain

- ✓ mine outline

In the spreadsheet the main groups for open-pit mining separated into soft rock and hard rock mining are shown.

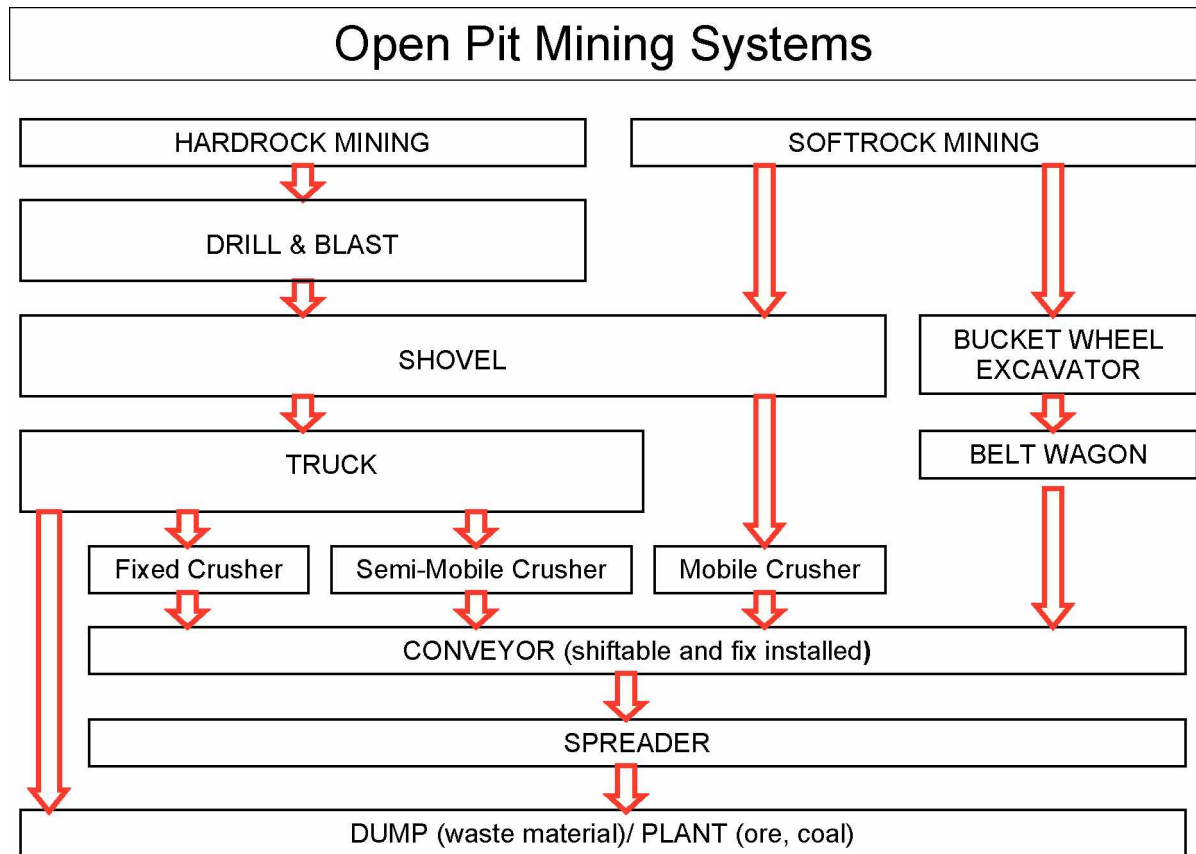

Fig. 3-1: Description of the conventional systems for open-pit mining

In the following there is a short description of the three conventional systems for open-pit mining, the field of application and their advantages and disadvantages.

3.1. Components used in open-pit mines

The following chapter describes the main components used in open-pit mines.

3.1.1. Drill and Blast (Surface Drill)

This technique normally requires a surface drilling unit.



Fig. 3-2: Surface drilling unit Type 1190 by Sandvik

A certain area of the mine where the top soil and overburden has already been removed is perforated by use of the surface drilling unit. This unit is responsible for drilling holes into the seam that allow the placement of explosives.

These units are most commonly self propelled and require diesel for their operation (movement and drilling). The unit by itself is operated by one person.

After the blasting is conducted the loosened material can be picked up and loaded into trucks.

3.1.2. Shovel excavator

The loading operation can be performed by different types of units such as shovel excavators or wheel loaders. In the figure, a shovel excavator Type 4100 XPB by P&H (Henry Harnischfeger and Alonzo Pawling) is shown.



Fig. 3-3: Shovel excavator Type 4100 XPB by P&H

A shovel excavator is normally powered by electricity; the wheel loader normally uses diesel fuel. The wheel loader is operated by one single person; the crew for the shovel excavator depends on the size and can range up to 4 people.

3.1.3. Truck

The transportation of the material is conducted by use of trucks.



Fig. 3-4: Haulage truck

The trucks travel between the loading and discharge points. In order to maintain a steady production it is required to plan the blasting operations in advance and have enough trucks available. These trucks are also operated by one single person and are diesel powered. The trucks must deliver the mined material to the drop off point and return empty to the loading point. In order to optimize the production it is common to use more than one truck (number of trucks depending on travelling distance and truck size).

3.1.4. Bucket Wheel Excavator

A bucket wheel excavator (BWE) is used for the mining process.



Fig. 3-5: Bucket wheel excavator Type VABE 1500 in Monticello/USA

The BWE wins the rock from the soft rock formation by use of its bucket wheel. The material is broken out from the formation and drops into the single buckets.

From there it drops down onto a chute leading to a belt conveyor. This conveyor runs through the excavator boom until it reaches the center point of the unit. From there the coal continues on a second belt conveyor over the discharge boom. From there it is dropped onto the belt conveyor system. In order to increase the mobility of the excavator it is possible to place a belt wagon between the excavator and the belt conveyor.

The conveyor system is composed of several belt conveyors.

The bucket wheel excavator composes of several main components. Those are:

- Bucket wheel
- Bucket wheel boom
- Superstructure
- Conveying belt
- Discharging boom
- Counterweight boom
- Swivel (2x)
- Crawler track with substructure
- Hydraulic jack for the bucket wheel

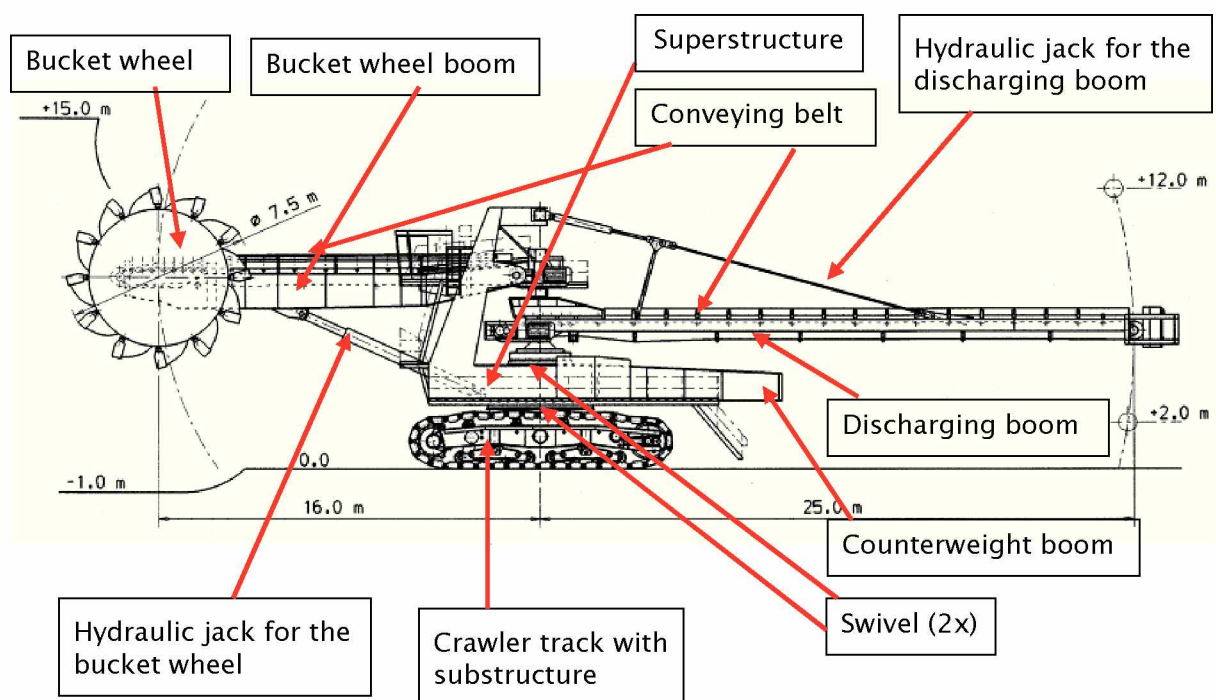

Fig. 3–6: Main components of a BWE

The excavation component itself is called bucket wheel and consists of a large rotating wheel mounted on the bucket wheel boom. The bucket wheel boom can be moved by a large hydraulic jack for the bucket wheel up and



down depending on the mining surface. On the outer edge of the wheel there is a series of scoops or buckets. As the wheel turns, the buckets remove the material from the target area and carry it around to the backside of the wheel, where it falls onto a conveying belt, which carries it up the discharging boom toward the superstructure of the excavator. For moving the discharging boom, a hydraulic jack for the discharging boom is installed, like for the bucket wheel boom. Additional conveying belts then may carry the mined material away through the discharging boom. The excavators come in different sizes. These units can be rail or crawler track mounted. For moving the BWE, a crawler track with substructure is used. Two swivels for rotating the superstructure are in use. These excavators are suited for the mining of soft rock materials only.

3.1.5. Belt wagon

For increasing the mobility of the excavator it is possible to place a belt wagon between the BWE and the belt conveyor.

After passing the BWE, the mined material goes through the belt wagon (BW).



Fig. 3-7: Belt wagon Type VABW 1800/ 31+36 in Neygeli/India

A BW consists of the following main components:

- Receiving boom winch system
- Discharge boom winch system
- Superstructure
- Discharge boom
- Crawler unit
- Receiving boom

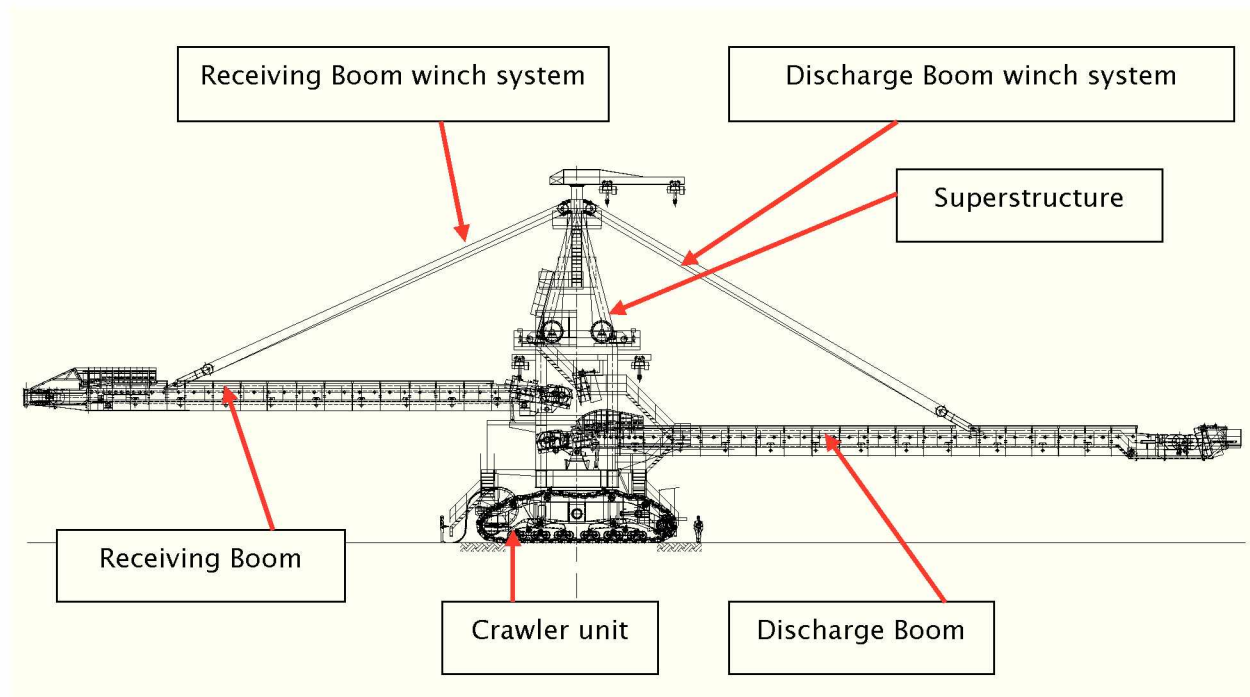

Fig. 3–8: Main components of a BW

The BW gets fed at the receiving boom with material. Hydraulic cylinders serve for the lifting and lowering of the receiving boom winch system and the discharge boom winch system. The discharge boom, from where the mined material is dropped off is located on the opposite side. The main part of a belt wagon is the superstructure between the receiving boom and the discharging boom. In this part the material gets transferred from the receiving boom to the discharge boom. For movement of the belt wagon, 2 crawler units under the superstructure are used. Each of the two crawlers is driven by a controlled hydraulic crawler drive motor.

For slewing the superstructure, it is supported by the undercarriage over a slewing ring which is secured against lifting.

3.1.6. Crusher

There are 3 different types of crusher used for in – pit crushing. Traditionally crushing plants were set up distant from the open–pit working area. In more recent years they have become located directly in the open–pit working area.

In – pit crushing plants can be set up as:

- a) Stationary Crushing Plants
- b) Semi–mobile Crushing plants
- c) Mobile Crushing Plants

3.1.6.1. Stationary Crusher

The main disadvantage of stationary crushing plants comes from the constantly increasing transport distance and lifting heights between the mining machine and the crushing plant.



Fig. 3–9: In–pit crusher at MRN in Brazil

In order to reduce the haulage costs, the transport and lifting works of the heavy trucks have to be considerably reduced or possibly completely eliminated. This means to mobilize the crushing plant, either completely or partially.

3.1.6.2. Semi-mobile Crusher

Nowadays, most of the open-pit mines generally consist of several levels. For reaching a higher output of the open-pit, and reducing the travel times of the trucks, the crushing plants are constructed semi-mobile.



Fig. 3-10: MMD Semi-mobile Sizer at Lignitos de Meirama/Spain

The crushed material is conveyed out of the open-pit mine by a stationary or shiftable belt conveyor system.

3.1.6.3. Mobile crusher

The material in most cases is won by blasting and is fed to the receiving hopper by means of wheeled loaders, excavators or heavy trucks. If the mobile plant is fed by heavy trucks, an access ramp has to be provided. The material size is reduced by the crusher. Depending on the type and size of crusher, throughput capacities in excess of 10.000 tones per hour can be achieved. A feed out conveyor transfers the crushed material to a shiftable conveyor system for transport out of the mine.

The in-pit crushing plant may be made mobile by:

- ◆ Rail Bound
- ◆ Walking Mechanism
- ◆ Pneumatic Tires
- ◆ Crawler track

- Rail Bound

The crushing plants can be moved on rails by electric or diesel motors. The movement has to be linear, because of the straight rails.

- Walking Mechanism

Hydraulic walking mechanisms make the machine move in several short steps on to the next location. Crushing plants with walking mechanisms can move

in every direction and can be rotated on the spot. The disadvantage of the hydraulic walking mechanism is the high cost for the hydraulic system and the maintenance.

- Pneumatic Tired

Crushing plants which are equipped with pneumatic tired travelling mechanisms can move in every direction and rotate at an angle of 360°. During the crushing operation the whole crusher is put down on its base feet for higher stability.



Fig. 3-11: Mobile crusher with pneumatic tyres

- Crawler Track

These are crushing plants which are moving on crawlers, therefore they can work and move on rough surfaces. The crushing plant follows the whole face machinery (surface drilling rig, wheel loader,...).



Fig. 3-12: Mobile crusher with crawlers

3.1.7. Conveyor

The mined material is transported out of the mine by a belt conveyor system (BC). The system consists of one or more belt conveyors. Normal belt conveyors have to be installed flattish. When the mining is advancing, there would be too long belt conveyors in use. In order to prevent that, so called lifting conveyors are in use. They can be installed very precipitous.

The belt conveyor system size is dependent on the excavator mining capacity. A typical BC or hauling coal in open-pit mines is shown in the figure below.



Fig. 3-13: Belt conveyor Type VABC 1600 in Tantalos/Mexico

The length of the conveyor system depends mainly on the mine outline. While this system is quite flexible in regard to transport capacities it is very inflexible in regard to changes in location.

Larger mines overcome this problem by mounting the conveyor system on tracks, which allows for easier relocation. No crew is required to be placed at the conveyor system during the whole shift (only maintenance work).

3.1.8. Spreader

After mining and hauling, the mined material normally has to be stored. For this task, a spreader (SP) is used.



Fig. 3-14: Spreader Type VASP 2200 in Mae Moh/Thailand

The spreader structure consists of the following main assemblies:

- Discharge Boom
- Receiving Boom
- Counterweight Boom
- Portal with Crawler Track
- Slew deck
- Bracing
- Hydraulic cylinder for discharge boom
- Tripper car
- Pylon

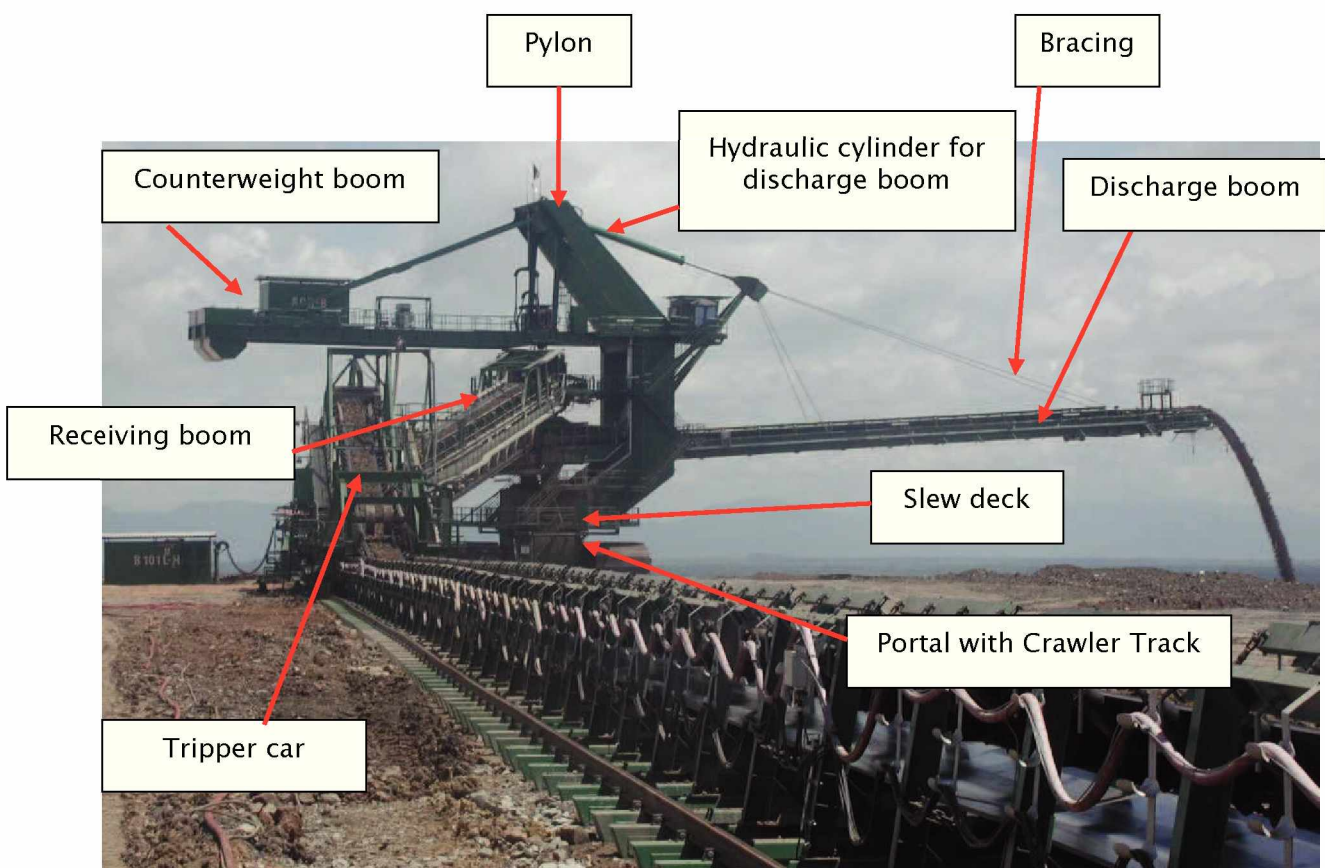

Fig. 3-15: Main components of a Spreader

The portal will form the actual supporting structure for the entire superstructure / boom and will consist of a box-shaped ring. The topside will support the slew bearing.

Three jacking points are provided at the structure for lifting the slewable superstructure to enable removal and replacement of the slew bearing.

The slewing ring-girder is housed at the slew deck and supports the entire boom bracing with hydraulic lifting equipment and consists of a solid box structure. Hydraulic cylinders for luffing operation of the discharge boom will be connected to the ring girder / turntable and the pylon. The pylon can be pivoted to the slew deck by a maintenance free spherical plain bearing. The discharge boom is a welded solid web construction with horizontal bracing which supports the boom conveyor. The conveyor is mounted within the boom.

The counterweight boom is located opposite the discharge boom and is connected via a bracing to the discharge boom. The counter weight consists of heavy reinforced concrete or steel blocks.

The rear travelling Tripper car trailer structure consists of the conveyor girder and portal frames.

3.1.9. Storage area

A storage area is used for storing the mined material. There are several types of storage areas (SA).



Fig. 3-16: Storage area for copper ore in Chuquicamata/Chile

The size of the surface area of the storage area depends on:

- ✓ Topology and geography of the planned storage area
- ✓ Environmental influences
 - Hills, coasts
- ✓ Investment costs
- ✓ Operating costs

Storage Areas can be either rectangular or circular parted.

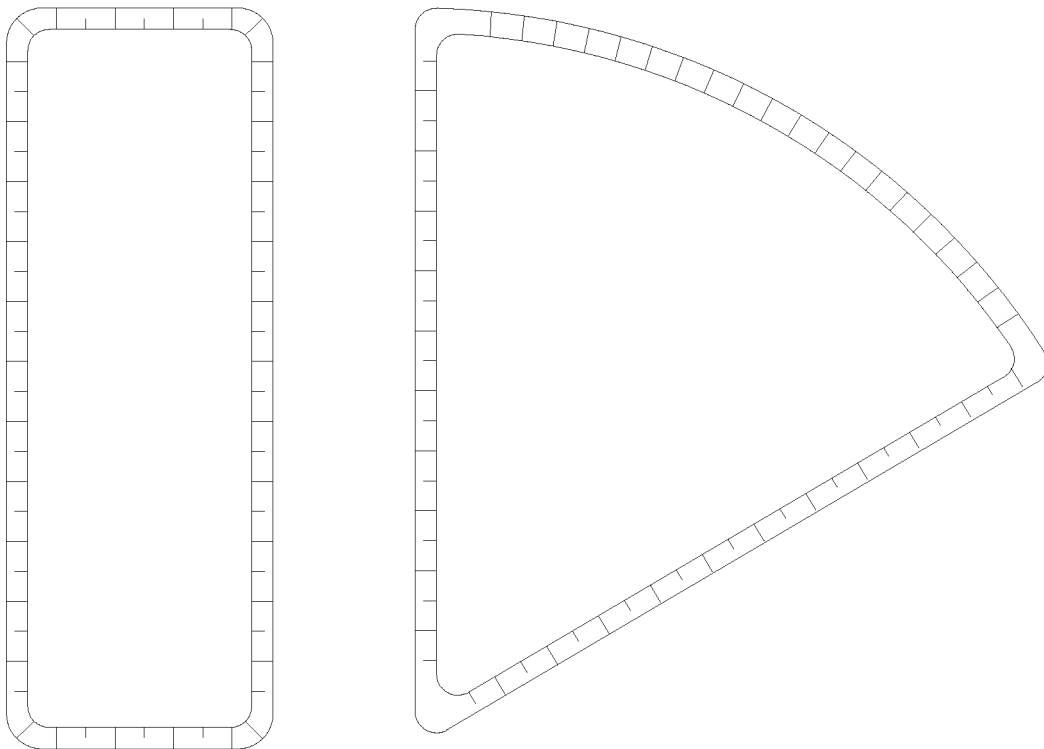

Fig. 3-17: Rectangular and circular parted storage area

The height of the stored material depends on:

- ✓ Grain size
- ✓ Possible production
 - tons/year
- ✓ environmental influences
 - snow
 - rain

- ✓ Material properties
 - Hard rock
 - Soft rock
 - Flammable (15 m)
 - Inflammable (50 m)

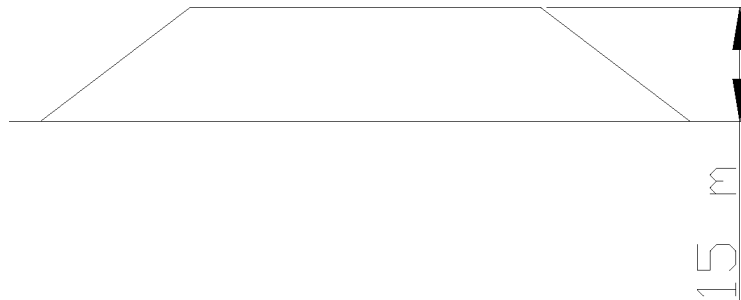

Fig. 3–18: Maximum height of a storage area for flammable material

Stockpile storages for coal can be built up to 15 m height. They must not be built higher than 15 m because of self ignition danger as a result of the friction.

The underground of the stockpile is also of interest for the storing process. It has to be strong enough to withstand the weight of the mined material. This mean, that the underground must get checked properly by geologists before storing.

Small stockpiles must be more often supplied with material than large stockpiles as a result of the small storage capacity. On the other hand, they need smaller and cheaper machines and belt conveyors.

Large stockpiles use big machines and long, broad belt conveyors which are more expensive than smaller ones. They have more conveying capacity for compensating the fluctuations of the bulk.

Important criteria for choosing the right type of stockpile storage are:

- ✓ Storage method
- ✓ Reclaimer
- ✓ Area outline
- ✓ Bulk material
- ✓ Stirring of the material

3.1.9.1. Design of storage areas

The first method is called “Chevron Method” and is the most used method for storing bulk. It is a very easy way for mixing the bulk material in a homogeneous way. The stored bulk can get reclaimed very simple and fast, for example by use of wheel loaders.

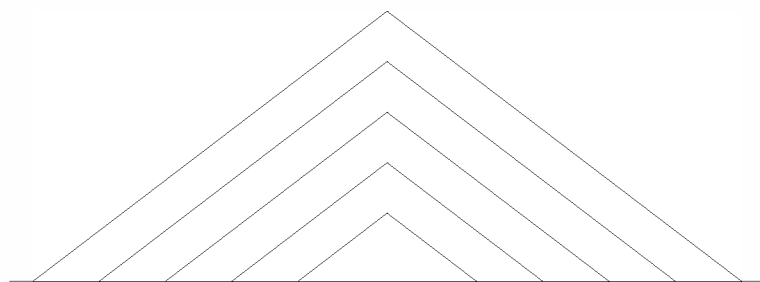

Fig. 3–19: Storage area – chevron

The second method, called “Windrow Method”, is very often used for mixing different bulk densities. The bulk becomes more homogeneous. Bigger rocks and stones are distributed throughout the stockpile. The stored bulk can again be reclaimed very simple and fast (wheel loader,...).

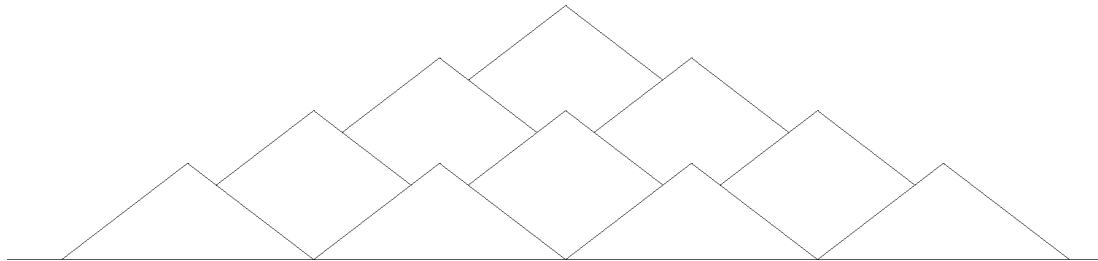

Fig. 3–20: Storage area – windrow

The system called “Cone Shell” is the last system to be discussed here. It is used for bulk, which is ready for processing. It does not need to be mixed or prepared in any way for the following industry.

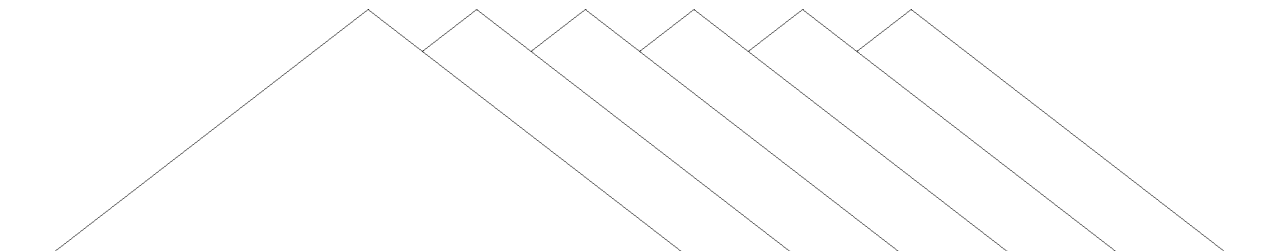

Fig. 3–21: Storage area – cone shell

3.2. Mining Methods

3.2.1. Continuous mining and haulage

The system called "*Continuous Mining and Haulage*" uses a bucket wheel excavator BWE for mining the material and possibly a belt wagon BW for transporting the mined material. The receiving boom of the BW is very close to the BWE. The discharging boom of the BW is directly connected with a belt conveyor BC or a system of belt conveyors. The BC system goes out of the mine and normally to a spreader SP which distributes the mined material to one or more SA.

3.2.1.1. Flow diagram for "Continuous mining and haulage"

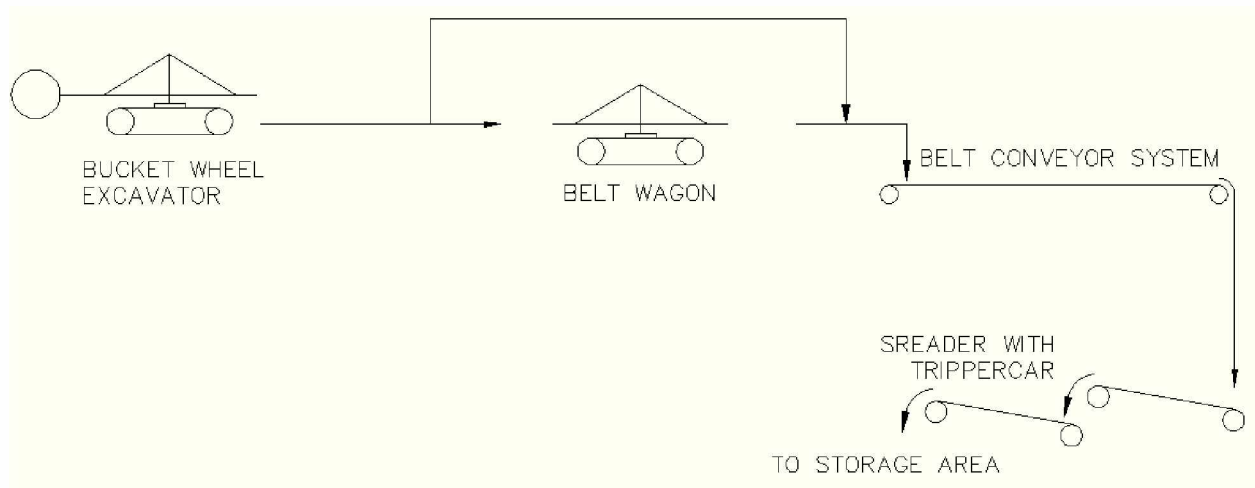

Fig. 3-22: Flow diagram for "Continuous mining and haulage"

3.2.1.2. Example of implementation (Köflach/Austria)

The system “Continuous mining and haulage” in Köflach/Austria was planned, constructed and supervised by VOEST ALPINE Bergtechnik in Zeltweg. It consisted of the following main components:

- Bucket Wheel Excavator BWE
- Belt Wagon BW
- Belt Conveyor BC
- Spreader SP

The BWE is shown in the Figure below.



Fig. 3–23: Bucket wheel excavator Type VABE 700 in Köflach/Austria

This BWE consisted of a BW supporting buckets with a full working capacity of about 280 l. The bucket wheel diameter was about 5.2 m and was powered by a 110 kW motor. It had a theoretical capacity of 1250 lm^3/h and a belt width of 1.0 m. The BWE was delivered in the year 1978 and taken out of service in 2002.

The BWE was connected via a BW to the BC.



Fig. 3-24: Beltwagon Type VABW 1400 in Köflach / Austria

This BW had a theoretical capacity of 4100 lm^3/h and was able to handle overburden and coal. The belt width was about 1.4m and the motor had a total installed power of 600 kW. The BW was delivered in 1977 and taken out of service in 2002. A Belt conveyor system is also shown in the figure above. After that, the mined material was transported to a SP and from there on to the SA.



Fig. 3-25: Spreader Type VASP 1600/20+30 in Köflach/Austria

3.2.2. Truck and Shovel

The system named *“Truck and Shovel”* uses a surface drilling rig for loosening the material by introducing explosives into the boreholes. After the explosion, the loose material is handled by some shovel excavators or wheel loaders. The shovel excavators can either be built with a rope for moving the bucket or hydraulic powered and feed several haulage trucks. That fleet of haulage trucks is commuting between the loading point and the discharge point and transport the material out of the mine instead of a BC system. There the material gets stored over a SP at a SA.

3.2.2.1. Flow diagram for “Truck and Shovel”

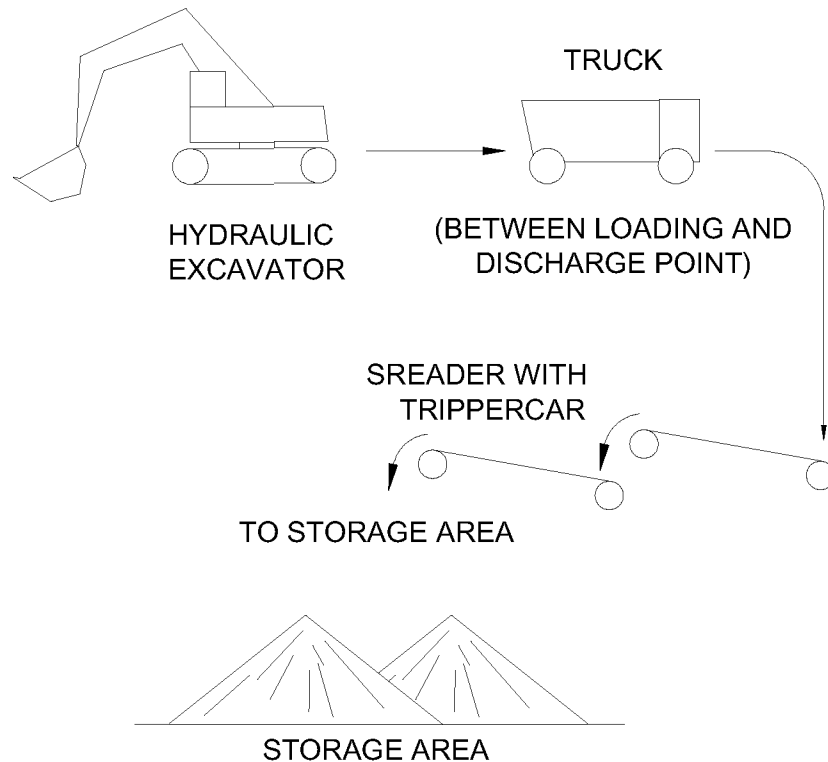

Fig. 3–26: Flow diagram for “Truck and Shovel”

3.2.2.2. Example of implementation (Kaltim Prima Coal Mine/Indonesia)

The mine is located in Kalimantan in the north-east of Indonesia and is operated by PT Kaltim Prima Coal (KPC) and works after the system “Truck and shovel”.

KPC tendered a 7900 km² area in eastern Kalimantan in 1978. The Exploration from 1982–1986 indicated reserves of 112 Mt of export-quality thermal coal. Construction began in 1989 and the mine was commissioned in 1991 as a 7 Mt/yr operation at a cost of \$570 million.

The mine has subsequently been expanded, with a sales target of 20Mt/yr by 2005.

In the mine, there is a total of 13 seams range in thickness from 1 to 15 m, typically in the range of 2,4 m to 6,5 m. The seam dips vary from 3° to 20° at the outcrop. The operation produces two main export products. Prima coal is a high -volatile bituminous steam coal with high caloric value and very low ash.



Fig. 3–27: Open-pit coal mine in Kalimantan/Indonesia

The overburden material degrades quickly on exposure to the atmosphere and generally provides easy digging. Some overburden rock requires blasting to ensure adequate fragmentation for the shovels. This is described in the following. At first, a mobile surface drilling unit bores holes in the material for filling them with explosives. After exploding, some shovel excavators pick up the exploded material and feed the trucks.



Fig. 3–28: Hydraulic shovel excavator Caterpillar Type 320B

The mine's loading fleet consist of over 20 large hydraulic shovels and backhoes with bucket capacities of up to 34m³. Leading suppliers include Hitachi, with nine EX3500 machines and six EX1800s, and Liebherr, which has six R996 Litronic shovels on site. Overburden haulage involves a fleet of 137 trucks, including Caterpillar 785S and 789BS with capacities of 135–185t, Cat 777s (85t) and Komatsu HD785s (also 85t). Truck scheduling is carried out using a GPS–based Minecom dispatch and management system.



Fig. 3–29: Hydraulic shovel excavators Liebherr Type R996 loading trucks in the pit

With selective mining, over 90% of the run-of-mine coal only needs crushing and blending to give export-quality Prima Coal. The trucks transport the material out of the mine to the crushing unit.



Fig. 3–30: Haulage trucks transport the material out of the mine to the crushing unit

After crushing to -50mm in rolls crushers, the washing plant uses cyclones for 0.5mm to 50mm feed, and spirals for the -0.5mm material, products being dewatered in centrifuges before blending into the stockpile.



Fig. 3-31: Spreader with 2 separate stockpiles

The mine site contains 2 separate stockpiles for the products, holding 60.000 t and 35.000 t respectively. Coal is reclaimed and transported by a 13 km -long, 2.100 t/h -capacity overland conveyor to Kaltim Prima's dedicated port facilities at Tanjung Bara. Coal is transferred directly from mine to ship whenever possible.



Fig. 3-32: Overland conveyor for ship onloading

Vessels of up to 220.000 dwt can be handled by the port, with loading facilities at the end of a 2 km-long jetty. Twin quadrant loaders can each handle up to 4.700 t/h, the normal loading throughput.

Since production began in 1992, Kaltim Prima has increased its output year-on-year, from 7.3 Mt in its first year to some 17 Mt in 2002 and 2003.

In early 2005, the Sangatta mine handled a new daily record tonnage of 84.260 t on its overland conveyor, while increasing the amount of coal crushed from the previous record of 73.650 t to 90.166 t on a daily basis.

3.2.3. Truck, Shovel and Conveyor

This system can be used for hard rock and soft rock mining too. There is also a drill rig used. The great difference is the BC behind the electric powered in-pit crushing plant.

At first, a drill rig drills holes in the surface so that they can be filled with explosives and blasted. After blasting, the mined material is transported by one or more excavators or wheel loaders to some trucks. The trucks are used for transporting the mined material not to the final drop-off point or discharge point but to a crusher which reduces the material size to make it adequate for transportation on a BC. There the material is crushed and sized and can be transported out of the mine by a BC system. After that, the material can be stored in a SA by a SP with tripper car.

3.2.3.1. Flow diagram for "Truck, Shovel and Conveyor"

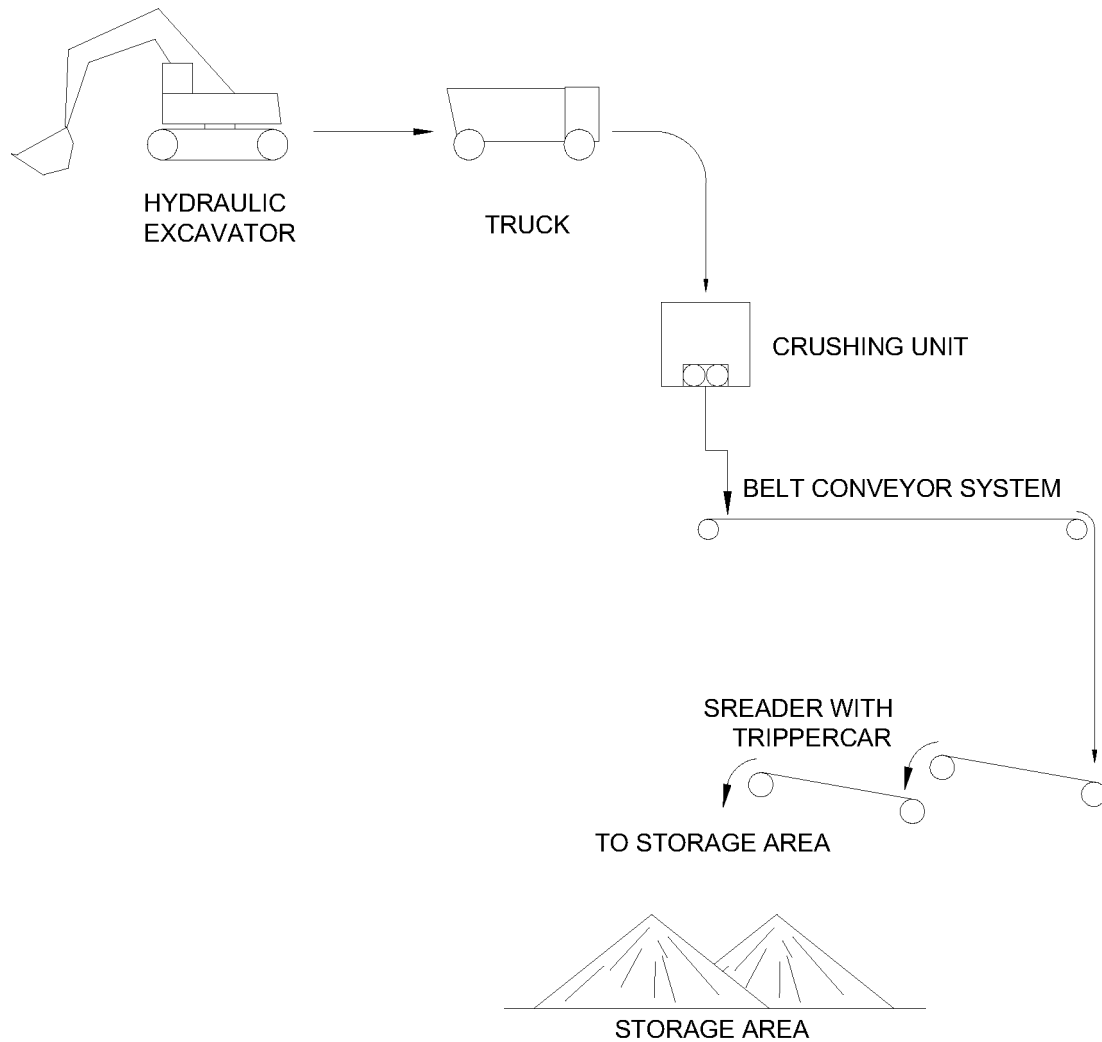

Fig. 3-33: Flow diagram for "Truck, Shovel and Conveyor"

3.2.3.2. Example for implementation (Mae Moh/Thailand)

The system “Truck, shovel and conveyor” is used in Mae Moh/Thailand and was planned, constructed and supervised by VOEST ALPINE Materials Handling. The Mae Moh open-pit mine is operated to feed a large coal fired power plant complex in Northern Thailand. The Mae Moh Mine is located in the Lampang district in the northern part of Thailand at an average sea level of 335 m. The removal of the overburden is planned in various phases of about nine years of operation. The contract came into force on 4th June 2001. The first of two production lines of 11.000 tons hourly capacity was taken into operation on 31st March 2002 after only 12 months project execution time. The second production system was commissioned after another two months.

The products supplied by VOEST-ALPINE Materials Handling for Overburden Removal consists of the following main components:

- 10 hydraulic excavator Hitachi EX2500E
- 40 trucks Euclid-Hitachi EH1700
- 4 semi-mobile crushing units MMD Sizer 1300 (capacity 5.500 t/h)
- 1 belt conveyor system BC consisting of fourteen conveyors (all 1800 mm wide, capacity 11.000 t/h)
- 2 overburden spreaders with tripper cars (capacity 11.000 t/h each)

The Mae Moh Overburden Removal System will be operated from the year 2002 to 2009. In an annual operation time of about 5.200 hours the scheduled annual production was about 27.5 Million m³ and 39.6 Million loose m³ respectively. Two independent continuous transportation systems includes 4 semi-mobile crushing units and 14 belt conveyors feeding the overburden material through a lift of 150 to 200 m to the dumping area where 2 spreaders with tripper car dump the overburden material. The Mae Moh Overburden Removal System basically consists of the mining and dumping area.



Fig. 3-34: Mine layout with mining and dumping area

In the mining area the overburden is after blasting excavated by 10 hydraulic shovel excavators and transported via 40 trucks to the crushing and conveying system.



Fig. 3-35: Hydraulic excavator Hitachi EX2500E loading a truck Euclid-Hitachi EH1700

After that, the mined material can be transported by some trucks to one of the four semi mobile crushing units. There the material gets crushed to a transportable size.



Fig. 3-36: MMD Semi mobile crushing unit

From the semi mobile crushing unit, the crushed and sized material drops on a BC which is connected with a SP with tripper car.



Fig. 3-37: Belt conveyor system VABCS 1800 in mine

The SP Type VASP 2000/50+50 has a theoretical capacity of 7.500 m^3/h and can handle overburden. It is connected with a Tripper car Type VATR 1800. The belt width is about 2.0 m and the total installed power is about 2.100 kW. The year of delivery is 2002.

Then the material is transported to a SA.



Fig. 3-38: Spreader Type VASP 2000/50+50 with Tripper car Type VATR 1800

3.3. Advantages and disadvantages of the conventional mining systems

The system "*Continuous mining and haulage*" can be used only for soft rock mining. This system is very often used for mining in large and very large mines.

The advantages of this system are that the machines are fully electrically powered and hence less costs. Another advantage is the high output of the system because it is a continuous operation.

The disadvantages are that this system can only be used for mining soft rock and is less flexible. The whole method requires a lot of personnel.

The system "*Truck and Shovel*" can be used for hard rock mining as well as for soft rock mining. It is most suitable for small mines. An electric power supply is not a prerequisite, since most of the machines are diesel powered like surface drilling rigs, trucks, excavators or shovels. The application of trucks and shovel make a plane or smooth underground necessary for driving the machines especially when they are pneumatic tyred.

The advantages of this system are that it is very flexible and that it is possible to mine hard rock and soft rock.

The disadvantages of the system "*Truck and Shovel*" are, that all machines and units are fully Diesel powered which produce higher operating costs. The output is not continuous and the trucks have very high empty-travel times when returning to the face of the mining system. Another disadvantage is allot or personnel depending on number of trucks.

Last not least the system *“Truck, Shovel and Conveyor”* can be used for hard rock and soft rock mining too. There is also a surface drilling rig used for loosening off the material and then blowing it away by explosives out of the drilled holes. This system is very suitable for small and large mines. One or more crushing units are in use in the pit.

The advantage is that the system is flexible and can be used for mining hard rock and soft rock like *“Truck and Shovel”*. It requires less personnel and the coal discharge from the conveyor can be regarded continuous.

The disadvantages are the partially diesel powered machines and units and an irregular output.

3.3.1. Comparison of the advantages and disadvantages of the 3 main methods

Nowadays steadily increasing oil prices generate tremendous costs for all equipment using fossil fuel. The oil price today lies well above 80 \$ per barrel. As a reminder: The oil price during the first Iraq war stayed just above 60 \$ per barrel.

This shows that today the oil market is strongly influenced not only by global crisis but also by the fact that oil and gas reserves are slowly depleting. It is not to be expected that the oil price will significantly drop in the future and therefore running fossil fuelled machinery will stay expensive (or even become more costly). Therefore it is obviously an advantage of running electrically powered equipment since electricity is not so dependent on the oil market (as there are numerous alternative sources to produce electricity from).

A continuous coal production is of course favourable, since the involved equipment can be used most efficient for that case.

One topic of special interest when talking about maintenance is correlated to all wheel supported equipment. Since the wheels used in open pit mining are of much larger dimensions than the ones in every day life they are of course much more expensive. In addition there are only very few suppliers (which increases the price in addition). Because of that the tires are quite hard to come by (tremendous supplying problems in the past few years). This results in two possibilities for the companies requiring that tires:

- Keep tires on stock (expensive storage costs)
- Order tires on time (long supply times, possibility of production stop due to not available tires)

Both possibilities are unfavourable, hence it is advisable to implement as less wheel supported equipment as possible into the production chain.

	Power costs	Wear	Personal	Continuity	Idle movement	Purchase price
Continuous mining and haulage	3	3	1	1	1	3
Truck and Shovel	1	2	3	3	2	2
Truck, Shovel and Conveyor	2	1	2	2	3	1

Fig. 3–39: Comparison of the advantages and disadvantages of the 3 main methods of open-pit mining

1 ... high

2 ... middle

3 ... low



The “Truck and Shovel” method as well as the “Continuous mining and haulage” method are looking back at several years of implementation in mines worldwide. However the “Truck, Shovel and Conveyor” method is superior to the “Truck and Shovel” method in most regards. Less maintenance costs and more constant output combined with an already crushed material reaching the storage area come at the only cost of losing a little bit of flexibility. Adequate planning in advance, which is in any case a prerequisite in all mining operations can easily counteract for this disadvantage. While not so suitable for small mines, because of the initial installation costs and procedures this method is very well suited for medium to very large mines and can come in combination with a continuous mining system, using partially the same conveyor system.

These considerations were at the beginning of developing a “*New continuous mining system for hard rock application*” which gets powered electrically with little operating costs and a high output for small, middle and large open-pit mines available.



4. New continuous mining system for hard rock application

4.1. Executive summary

The deposit is covered by overburden and comprises copper ore oxide and sulphide.

Bank density of overburden and ore	2.7 t/m ³
Bulk density on conveyors	1.7 t/m ³

The mine plan is scheduled for 25 years operation with 775 million m³ mined overburden and copper ore.

In the first three years 20 million m³ per year shall be mined from level 425 m to 410 m.

In the 4th year 30 million m³ shall be mined, herein are 18.3 million m³ overburden and 11.7 million m³ overburden. The further development of mining is shown in the table below.

Year	Level	Width in m	Volume in mio m ³	Stripping volume in mio m ³
1	425	15	20,0	20,0
2	417	8	20,0	20,0
3	410	7	20,0	20,0
4	400	10	30,0	11,7
5	390	10	30,0	11,6
6	380	10	29,4	10,9
7	375	10	27,5	9,0
8	360	10	25,5	7,0
9	350	10	23,0	4,1
10	340	10	23,0	4,1
11	330	10	23,0	4,1
12	320	10	22,0	3,1
13	310	15	22,0	3,1
14	295	15	21,5	2,6
15	280	15	21,5	2,6
16	265	15	21,5	2,6
17	250	15	21,5	2,6
18	235	15	21,5	2,6
19	220	15	21,5	2,6
20	205	15	21,5	2,6
21	190	15	21,5	2,6
22	175	15	21,5	2,6
23	160	15	21,5	2,6
24	145	15	21,5	2,6
25	130	20	21,5	2,6
26	110	20	21,5	2,6
27	90	20	21,5	2,5
28	70	20	21,5	2,2
29	50	30	21,5	2,2
30	20	60	21,5	1,5
31	-40	60	20,4	1,4
32	-100	60	20,3	1,4
33	-160	60	20,3	1,4
34	-220	60	20,1	1,2
35	-280	60	13,6	0,5
			775,6	176,8

Fig. 4-1: General mining plan for the next 35 years

Sandvik offers the most modern mining and crushing system that combine high efficiency, availability and capacity.

There are three main areas in the plant with the following design capacities:

- Mining Area Design Capacity 2 x 8.000 t/h
- Spreading Area Design Capacity 2 x 8.000 t/h
- Stockyard and Bunker Storage Design Capacity 2 x 8.000 t/h

The system is structured in the following groups and comprises the following equipment:

a. Drilling equipment

Sandvik's offer considers Sandvik Surface Drill Rig Type 1190E. The mining plan indicates that in the first two years mainly overburden is removed which requires less drilling work than the copper ore.

b. Loading equipment

The capacity calculation shows that the scheduled annual production requires a design mining production of 2 x 8.000 t/h. For the loading, 2 rope shovel excavator from P&H Type 4100 XPB and 3 wheel loader by LeTourneou Type L-2350 are considered.

c. Mobile crushers

The excavator loads into the hopper of the mobile crusher which follows the excavator during operation. The package considers 2 fully mobile crushing units by MMD 1500 Series with slewable turntable and capacity 8.000 t/h each.

d. Mine conveyor system

The mining system comprises two production lines, line A and line B.

The discharge boom of the mobile crusher loads onto the belt wagon to feed to the face conveyor. From the face conveyor the material is transferred to the run of mine conveyors. The run of mine conveyors are for an elevation of about 90 m which means about 10 year of operation. Thereafter in lower mining levels the installation of two steep incline conveyors is recommended.

e. Spreading system

The spreading system comprises an overland conveyor and shiftable conveyor at the waste dump area. From the tripper car the material is dumped via a spreader with 50 m receiving boom length and 50 m discharging boom length to enable low travelling.

The plant comprises the following main areas:

- Mining area (surface drilling, loading, in-pit crushing and conveying)
- Dumping area (for overburden)
- Stockyard and bunker storage area (for copper ore)
- Concentration plant (not offered by Sandvik)

The plant equipment is designed for the following capacities:

Mining area	Design capacity 2 x 8.000 t/h
Dumping area	Design capacity 1 x 10.000 t/h
Stockyard and bunker storage area	Design capacity 2 x 8.000 t/h
Concentration plant	Design capacity 1 x 6.300 t/h

4.2. General layout

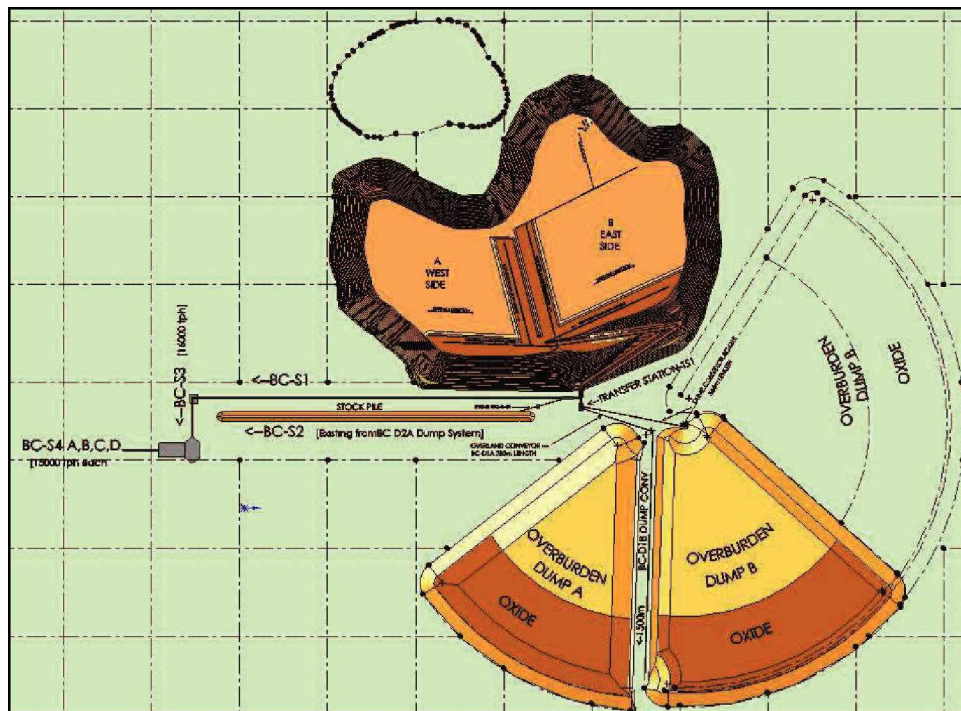

Fig. 4–2: General plant layout

In the general plant layout, there can be the following areas and units seen. The dumping areas A and B for dumping overburden in the south - east and south of the pit. The two main wings of the pit with the main conveyors BC-M1A, BC-M1B, BC-M2A and BC-M2B. The connecting conveyor to the concentrating plant can also be seen.

4.3. Flow diagram

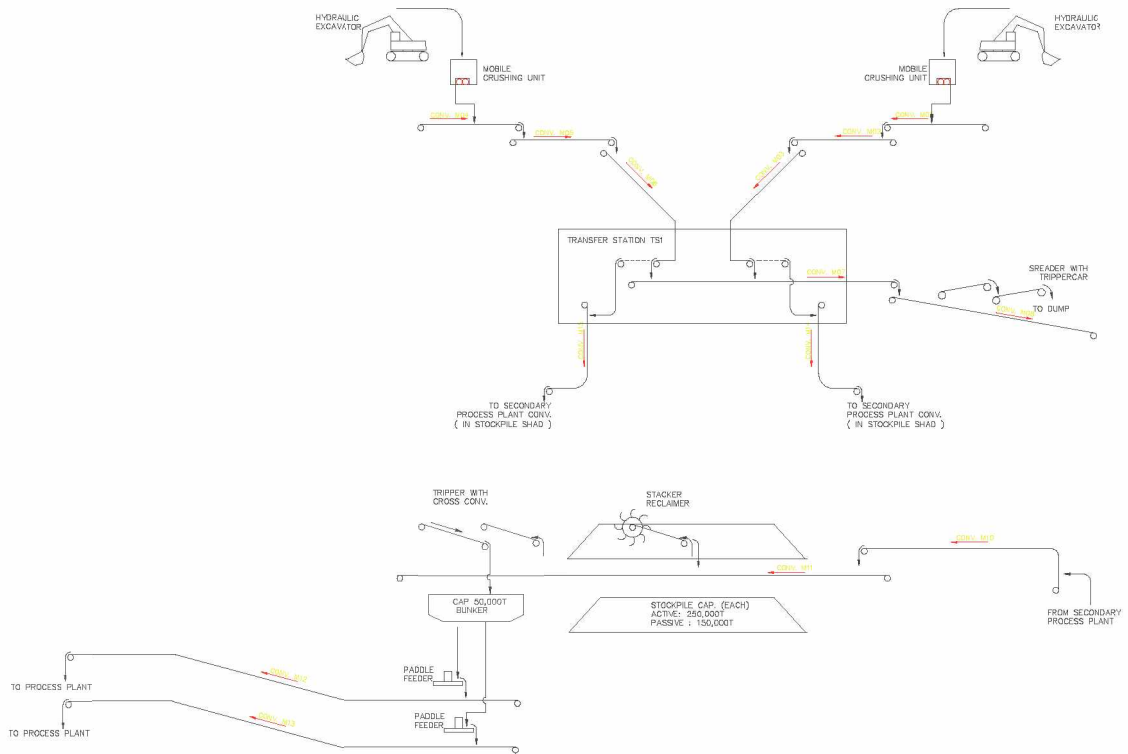

Fig. 4-3: Flow diagram for "New continuous mining system for hard rock application in Aktogai / Kazakhstan"

4.4. Mining Concept

The following planning parameters were discussed and agreed on the concept of mining the top bench and the lower benches:

- Out-of-pit (“lifting”) conveyors BC-M6A and BC-M6B to be extended in steps of 30 m, i.e. 2 bench heights
- Two out-of-pit lifting conveyor lines BC-M3A and BC-M3B and BC-M6A and BC-M6B are operating with 8.000 t/h rated capacity and 9.600 t/h peak capacity
- Annual production according to schedule is 50 Mt/a of ore, requiring between approx. 21 and 30 Mbm³/a of ore and overburden
- Mine life is 32 years, resulting in mining from +425 m down to + - 140 m level

The mine Production Schedule is shown in the figure below.

Calendar plan for overburden preparation and mining at Aktogai quarry

Year	Level	Rock volume, mln m ³	Sulphide ore mining			Overburden mln. m ³
			ore, mln tonns	%	Cu, thousands tonns	
1	410-425	30	-	-	-	30
2	410-425	30	-	-	-	30,0
3	395-410	30	50	0,38	190	11,1
4	380-395-410	30	50	0,38	190	11,1
5	365-380-395	30	50	0,38	190	11,1
6	350-365-380	26	50	0,38	190	7,1
7	350-365	26	50	0,38	190	7,1
8	335-350	24	50	0,39	195	5,1
9	320-335	24	50	0,39	195	5,1
10	290-320-335	23	50	0,39	195	4,1
11	290-320	23	50	0,39	195	4,1
12	290-320	23	50	0,39	195	4,1
13	275-290	24	50	0,39	195	5,1
14	260-275	24	50	0,39	195	5,1
15	245-260	23,3	50	0,39	195	4,1
16	230-245	23,3	50	0,39	195	4,1
17	215-230	24	50	0,38	190	5,1
18	200-215	24	50	0,38	190	5,1
19	185-200	24	50	0,38	190	5,1
20	170-185	24	50	0,38	190	5,1
21	165-170	24	50	0,35	175	5,1
22	140-165	24	50	0,35	175	5,1
23	110-140	24	50	0,34	170	5,1
24	80-110	24	50	0,32	160	5,1
25	50-80	23	50	0,36	180	4,1
26	20-50	23	50	0,34	170	4,1
27	-10-20	24	50	0,34	170	5,1
28	-40-(-10)	25	50	0,34	170	6,1
29	-70-(-40)	19,6	41,5	0,33	137	3,9
30	-100-(-70)	8,6	16,7	0,32	53	2,3
31	-130-(-100)	6,1	11,1	0,31	34	1,9
32	-160-(-130)	1,3	2,4	0,32	8	0,4
Total		736,2	1371,7	0,370	5067	217,1

Fig. 4-4: Mine production schedule – information from KCC

Equipment Description

- Shiftable conveyors BC-M1A, BC-M1B, BC-M2A, BC-M2B, BC-M3A, BC-M3B, with 2 shifting rails, length of drive head station 60 m
- Lifting conveyors BC-M6A, BC-M6B, not shiftable
- 2 rope shovels by P&H 4100 XPB
- 3 wheel loader by LeTourneou; Type L-2350
- 2 mobile double-roll crusher plants with slewable discharge boom; by MMD Type 1500
- 4 belt wagons, with two liftable booms 30 + 38 m; Type VABW 1800/40+45
- 2 transport crawlers, jointly used in mine and on dump

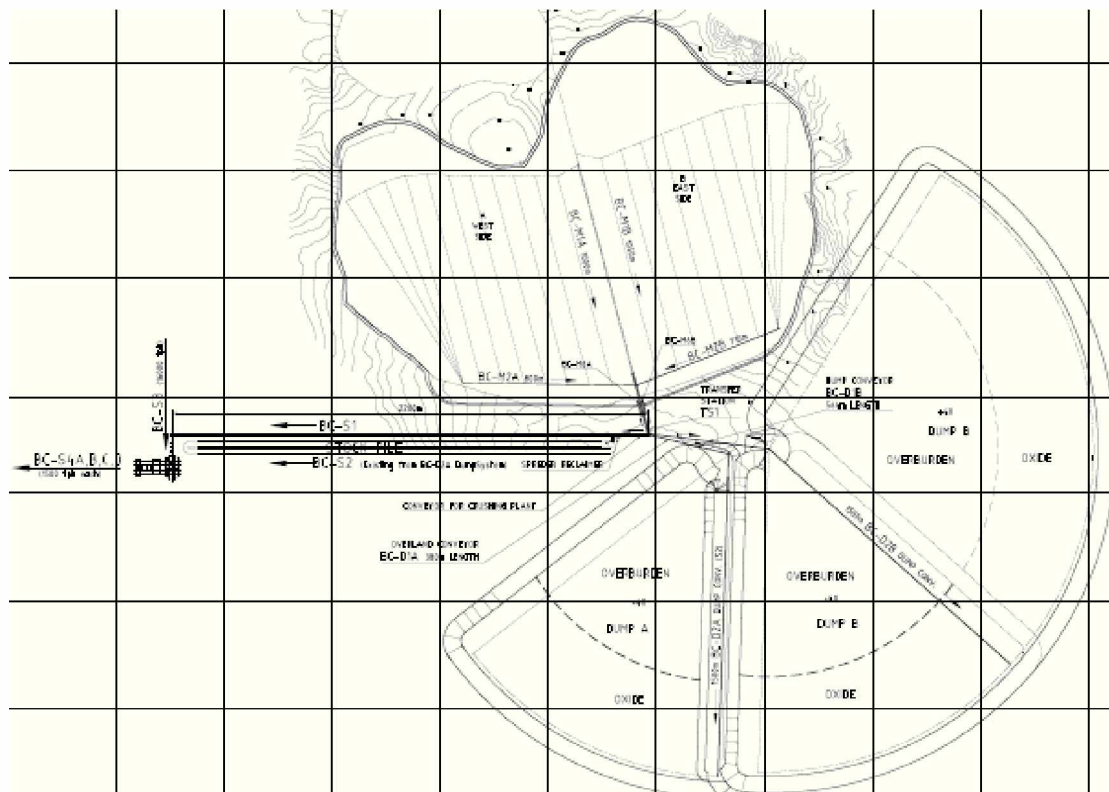

Fig. 4-5: Aktogai – General plant layout 1

Bench Development and Operation

In the following, the system and time schedule for preparing the tracks and installing the belt conveyors and machines in the pit gets described. The single stages have to be compared with the depending mining plan drawings.

The advance from the center line to the eastern and western border is a sequence of conveyor shifting cycles. In order to protect the conveyor from fly rocks, one blasted block of 20 m width is always left as a cushion between an area-blast and the conveyor. The development of the top bench from surface is described below for the western wing. The development of the eastern wing is homologous and the development of lower benches starting from a higher bench is analogous.

1st Phase

- Prepare track between drive station on surface to discharge point of connecting conveyor on surface with the wheel loader by LeTourneau Type L-2350
- Dig ramp from surface to -15m level with auxiliary equipment, possibly ground preparation by drilling and blasting by surface drilling rigs type 1190E; width approx. 50 m = 20.000 bm³
- Install lifting conveyors BC-M3A, BC-M3B between discharge point and -15 m level **after** blasting the extension area (75 m x 120 m x 15 m = 135.000 bm³ with auxiliary equipment)
- Extend the trench on -15 m level horizontally by approx. 60 m, using standard mining equipment (see above) and discharging onto the lifting conveyor

2nd Phase

- Blast of shiftable conveyor tracks in full length and 120 m width **before** installing the conveyors BC-M1A and BC-M1B
- Prepare track and install both shiftable conveyors BC-M1A, BC-M1B, discharge on lifting conveyors BC-M6A and BC-M6B
- Blast 6 blocks (1, 2, 3, 4, 5, 6) east of conveyor track BC-M1B and west of conveyor track BC-M1A, (mine development from now on: two equal wings)
- Ready for start of mining (Fig. 4-6: Aktogai - Mine Bench - Stage 1), start digging from north end to south end

Fig. 4-6: Aktogai – Mine bench – Stage 1

- Dig block 1 with rope shovels 4100 XPB by P&H, from surface to - 15 m, inclination 10:1, block width 20 m; one belt wagon Type VABW 1800/40+45 stays on surface
- Access ramp to working level on north end
- Dig Blocks 2, 3, 4, 5 (Fig. 4-7: Aktogai - Mine Bench - Stage 2); leave old ramp in place or build new access ramp in Block 5 location (Fig. 4-8: Aktogai - Mine Bench - Stage 3); one belt wagon Type VABW 1800/40+45 on surface level
- Leave blasted Block 6 in place for protecting conveyors and equipment
- Mining of the eastern wing in the same way (Block 1a, 2a etc.- Fig. 4-9: Aktogai - Mine Bench - Stage 4)

3rd Phase

- Drill and blast an area of 80 m width (5 blocks) and full length of connecting conveyor BC-M2A and BC-M2B; near the transfer points **before** installation of lifting conveyors BC-M3A, BC-M3B (Fig. 4-10: Aktogai - Mine Bench - Stage 5)
- Lay out connecting conveyor BC-M2A and BC-M2B next to blasted area on grown and levelled track, connect it to lifting conveyor BC-M3A, BC-M3B on ground level (Fig. 4-11: Aktogai - Mine Bench - Stage 6)
- Dig Block 6, 7, 8, 9 from - 15m working level, leave Block 10 in place; one belt wagon on surface level (Fig. 4-12: Aktogai - Mine Bench - Stage 7)

Fig. 4-7: Aktogai – Mine bench – Stage 2

Stage 4

Fig. 4-8: Aktogai – Mine bench – Stage 3

Stage 6

Fig. 4-9: Aktogai – Mine bench – Stage 4

Fig. 4-10: Aktogai – Mine bench – Stage 5

Fig. 4-11: Aktogai – Mine bench – Stage 6

Fig. 4-12: Aktogai – Mine bench – Stage 7

Fig. 4-13: Aktogai – Mine bench – Stage 8

4th Phase

- Doze down the blasted soil west of shiftable conveyor track with 1:3 slope (Fig. 4-13: Aktogai – Mine Bench – Stage 8)
- Dig and prepare ramp for lifting conveyor track down to – 15 m
- Extend the lifting conveyor down to –15 m level (Fig. 4-14: Aktogai– Mine Bench – Stage 9)
- Shift the connecting conveyor BC–M2A and BC–M2B down to position of Block 4 on –15 m level and connect it with the lifting conveyor BC–M3A, BC–M3B on this level (Fig. 4-15: Aktogai– Mine Bench – Stage 10)
- Block 10 in connecting conveyor area: blast remains stay in place as protection from future blasts
- Safety distance between connecting conveyor and blasting site approx. 50 m.

Stage 9

Fig. 4-14: Aktogai – Mine bench – Stage 9

Stage 10

Fig. 4-15: Aktogai – Mine bench – Stage 10

5th Phase

- Dig the area behind (east of) the shiftable conveyor BC-M1B and behind (west of) the shiftable conveyor BC-M1A in the center of the mine area (Fig. 4-16: Aktogai- Mine Bench Stage 11)
- Continue face advance in parallel moves towards the western (and eastern) mining limit; relocate access ramp in the northern part every 2 months, if applicable
- Belt shifting after loading 4 blocks in western (and eastern) direction, always **after** blasting of 4 blocks and leaving one block as protection for the conveyors
- Finish mining of first bench of 15 m height

6th Phase

- Drill and blast 7 blocks in the center of the mine from -15 to -30 depth
- Install shiftable conveyor of western wing in the center on - 15 m level while the eastern wing continues to advance towards the eastern mining limit (Fig. 4-17: Aktogai - Mine Bench - Stage 12)
- Dig 5 blocks in the center from -30 m level; one belt wagon on -15 m level

Fig. 4-16: Aktogai – Mine bench – Stage 11

Stage 11

Stage 12

Fig. 4-17: Aktogai – Mine bench – Stage 12

7th Phase

- Doze down the first block (5) to form ramp with 3:1 inclination
- Shift the connecting conveyor BC-M2A, BC-M2B down to -30 m level; connect it to lifting conveyor BC-M3A, BC-M3B (Fig. 4-18: Aktogai - Mine Bench - Stage 13)
- Dig 6 blocks (8, 9, 10, 11, 12 and 13) from center position of shiftable conveyor (Fig. 4-19: Aktogai - Mine Bench - Stage 14)
- Start eastern wing after reaching the mining limit (block 6,7) on -30 m level (Fig. 4-19: Aktogai - Mine Bench - Stage 14)

8th Phase

- Mine 4 blocks (14-17) in the area of connecting conveyor on -30 m level (Fig. 4-19: Aktogai - Mine Bench - Stage 14)
- Doze down block 14 and build ramp with 3:1 inclination
- Shift connecting conveyor down to -30 m level and connect it to lifting conveyor (Fig. 4-19: Aktogai - Mine Bench - Stage 14)

9th Phase

- Continue mining of 2nd bench like 1st bench.

Stage 13

Fig. 4-18: Aktogai – Mine bench – Stage 13

Stage 14

Fig. 4-19: Aktogai – Mine bench – Stage 14

Mining at the Return Station of Shiftable Conveyor

With 2 belt wagons the bench can be extended by 155 m beyond the return station. If a belt wagon from the east wing is brought in, 215 m are possible.

Evaluation

The method of developing a bench from surface (or the next lower bench from the higher one, respectively) requires extensive area blasting in advance. Area blasting as such requires a higher explosives factor than bench blasting.

The down-shifting of conveyors on an inclined surface dozed down by bulldozer has raised concern. The advantage as compared to dismantling and re-erection is, that the inclined surface can be prepared without interrupting the loading operation at the other conveyor. Down-time is suffered only for extending the lifting conveyor (about 3 days). The concern of down-shifting has been dropped by KCC, but the concern on extensive area blasting is maintained.

The distance to blast is kept low (about 40 m) by always leaving a 20 m safety block of blasted material in place between the blasting area and the conveyors. The shifting distance is 4 blocks of 20 m = 80 m, using the span of the 2 belt wagons.

The excavator digs blocks of 20 m width and thereby has an optimum swing angle of 90° (except the initial trench, where the width is 30 m and the swing angle is 180°). Nevertheless, the capacity of the excavator / crusher plant is short of the stipulated 8.000 t/h effective capacity.

5. Dump operation

5.1. Dump Area

5.1.1. Equipment of spreading system for dumping

The whole spreading system consists of the following elements:

- 1 Overland Conveyor BC-D1A Type VABCS 1800

This belt wagon has a nominal capacity of 8.000 t/h and a maximal capacity of 9.600 t/h. The belt width is 1.800 mm.

The length of the BC-D1A is 1775 m and it is shiftable. This belt conveyor weighs about 1.760.000 kg and gets powered by a 3.750 kW motor.

- 1 Dump Conveyor BC-D2A Type VABCS 1800

The conveyor BC-D2A has a length of 1.500 m and is shiftable. The conveyor BC-D2A weighs about 1.480.000 kg and gets powered by a 2.400 kW motor.

- 1 Overland Conveyor BC-D1B Type VABCS 1800

The conveyor BC-D1B has a length of 100 m and is stationary. The conveyor BC-D1B weighs about 2.990.000 kg and gets powered by a 1.250 kW motor.

- 1 Dump Conveyor BC-D2B Type VABCS 1800

The conveyor BC-D2B has a length of 2.200 m and is shiftable. The conveyor BC-D2B weighs about 2.700.000 kg and gets powered by a 4.550 kW motor.

- 1 Stockyard Conveyor BC-S1 Type VABCS 1800

The conveyor BC-S1 has a length of 2470 m and is stationary. The conveyor BC-S1 weighs about 2.990.000 kg and gets powered by a 6.250 kW motor.

- 1 Stockyard Conveyor BC-S2 Type VABCS 1800

The conveyor BC-S2 has a length of 2470 m and is stationary. The conveyor BC-S2 weighs about 2.700.000 kg and gets powered by a 5.800 kW motor.

- 1 Spreader Type VASP 2000/50+50

The length of the receiving boom is 50 m; the length of the discharging boom is 55 m. The spreader weighs about 7.730.000 kg and gets powered by a 2.500 kW motor.

- 1 Tripper Car Type VATR 1800

The tripper car gets powered by a 100 kW motor and has a weight of about 132.000 kg.

- 1 Stacker/Reclaimer Type VASR 2000/50+35

This Stacker/Reclaimer has a nominal capacity of 8.000 t/h and a maximal capacity of 9.600 t/h for stacking and reclaiming. The belt width is 1.800 mm. The length of the receiving boom is 50 m, the length of the discharging boom is 50 m; the length of the bucket wheel boom is 35 m. The whole unit has a weight about 1.160 kg and gets powered by a 2.500 kW motor.

- 1 Collapsible Tripper Car Type VATR-c 1800

The collapsible tripper car gets powered by a 300 kW motor and has a weight of about 190.000 kg.

5.1.2. Dumping Schedule

In the 1st and 2nd year both dumps are operated. In the 3rd year one dump is closed, the spreader Type VASP 2000/50+50 is modified to a stacker/reclaimer Type VASR 2000/50+35 and transferred to the storage and blending yard (Fig. 5-1: Aktogai - Dump Area A - Spreader Operation with BC - D2A/B) along with the tripper car Type VATR 1800 and the conveyors.

The schedule is developed from the Production Plan. Oxidic ore extracted in production the 2nd year, which is deposited separately for future leaching. The required dumping capacity in the 1st and 2nd is 47.6 Ml^m³/a. In the 3rd year the required dumping capacity is only 18.6 Ml^m³/a of waste and can be handled by one conveyor/spreader system. The overburden production is gradually decreasing to 6.5.Ml^m³/a in year 10 and finally to 4.1 Ml^m³/a.

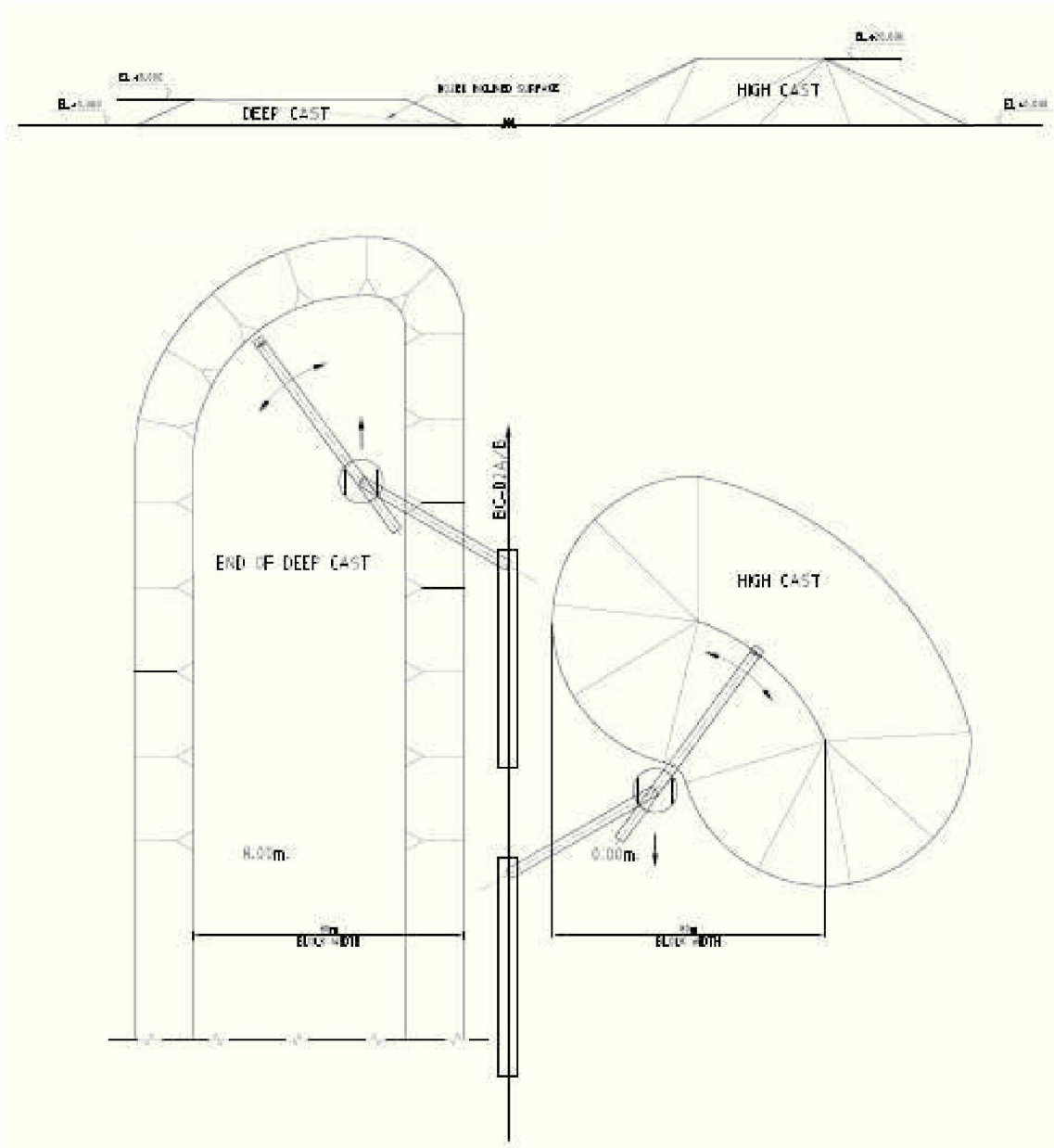

Fig. 5-1: Aktogai- Dump Area A – Spreader Operation from BC – D2A/B

5.1.3. Dumping Concept

The dumping concept is a slewing operation of the dump conveyor with a permanent pivot point. The pivot point must be relocated only once, from surface level to the working level of the spreader on + 20 m. The dump is operated in 3 Stages: 1st year, 2nd year, 3rd to 32nd years.

Stage 1 – 1st year

For dumping of overburden in the 1st year (the 1st stage) both conveyor/spreader systems A and B are employed (Fig. 5-2: Aktogai – Dump Area A – Cross Section and Fig. 5-3: Aktogai – Dump Area B – Cross Section).

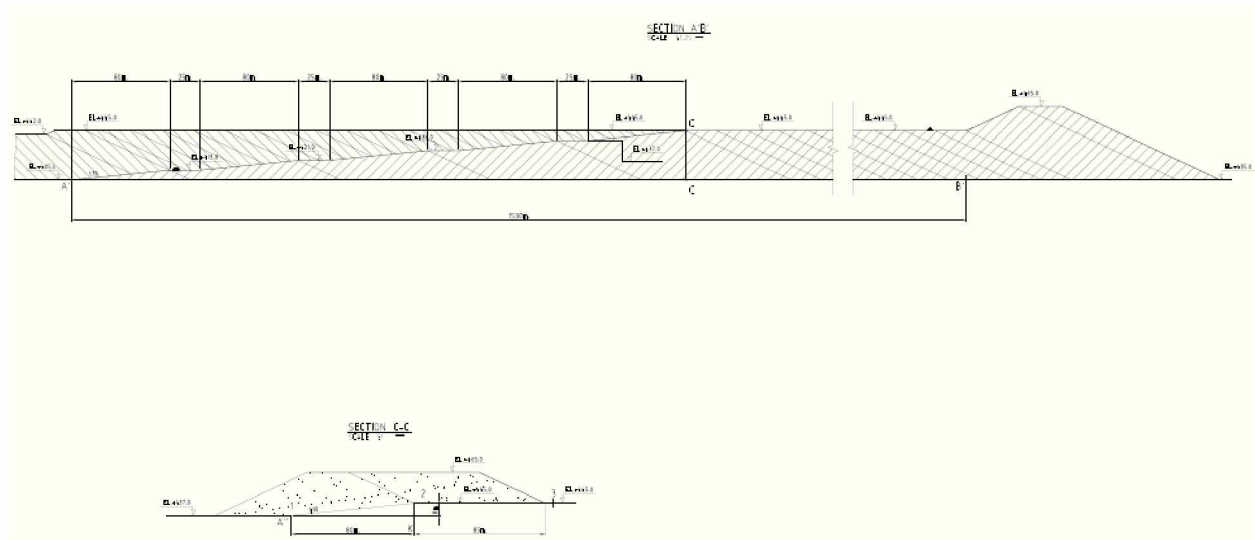

Fig. 5-2: Aktogai – Dump Area A – Cross Section

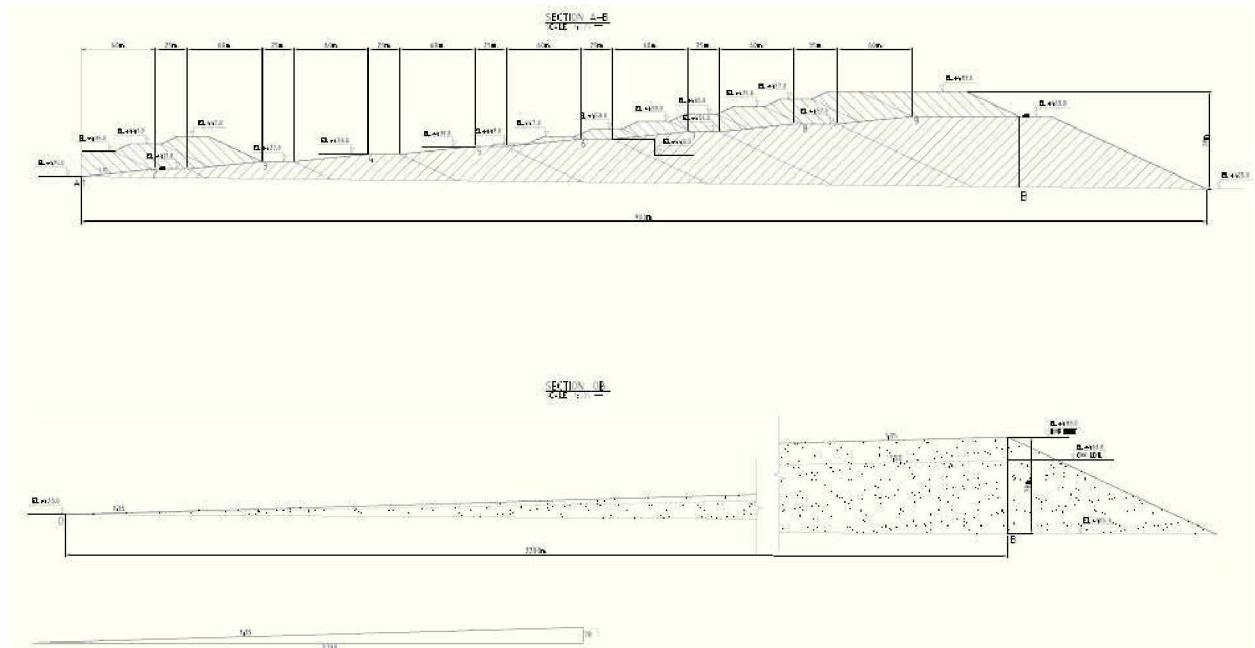

Fig. 5-3: Aktogai – Dump Area B – Cross Section

P750-DUMP-CROSS-SECTION-SKETCH-060817-1

The dump conveyors and the spreaders are located separate from each other on surface level and create dumps of 20 m height in high cast in slewing advance in year 1 (Fig. 5-4: Aktogai – Dump yard in year 1).

Stage 2 – 2nd year

Then at the start of 2nd year (the 2nd stage) the dump conveyors are shifted up to + 20 m level, also the tripper cars and the spreaders. The overland conveyors are extended, their drive head stations are moved up to the new slewing points on + 20 m level. Thereafter regular dump operation takes place with 20 m high cast by both conveyor/spreader systems, with oxidic ore deposited near the pivot point and waste to the outside of the slew. In this way a continuous body of oxidic ore with a volume of 50 Ml^m³ in a thickness of 20 m is created in the vicinity of the secondary crushing plant, which in future may be either reclaimed or leached in-site. The waste is kept separate from the oxidic ore.

At the end of 2nd year one conveyor/spreader system is taken out of operation and transferred to the storage and blending yard (Fig. 5-5: Aktogai – Dump yard in year 2). The other one has reached the rim of the dump of the 1st year on + 20 m level.

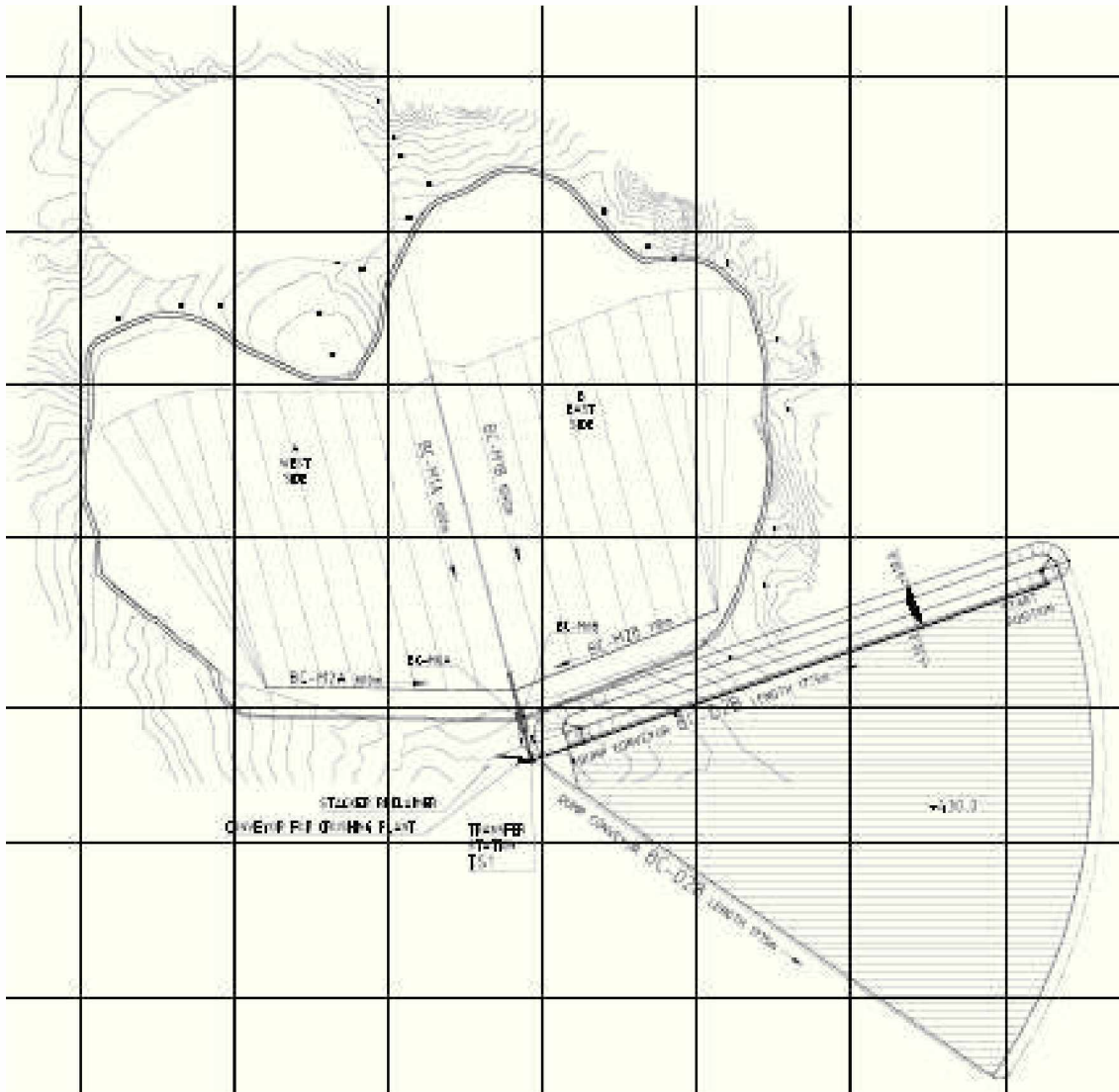

Fig. 5-4: Aktogai – Dump yard in year 1

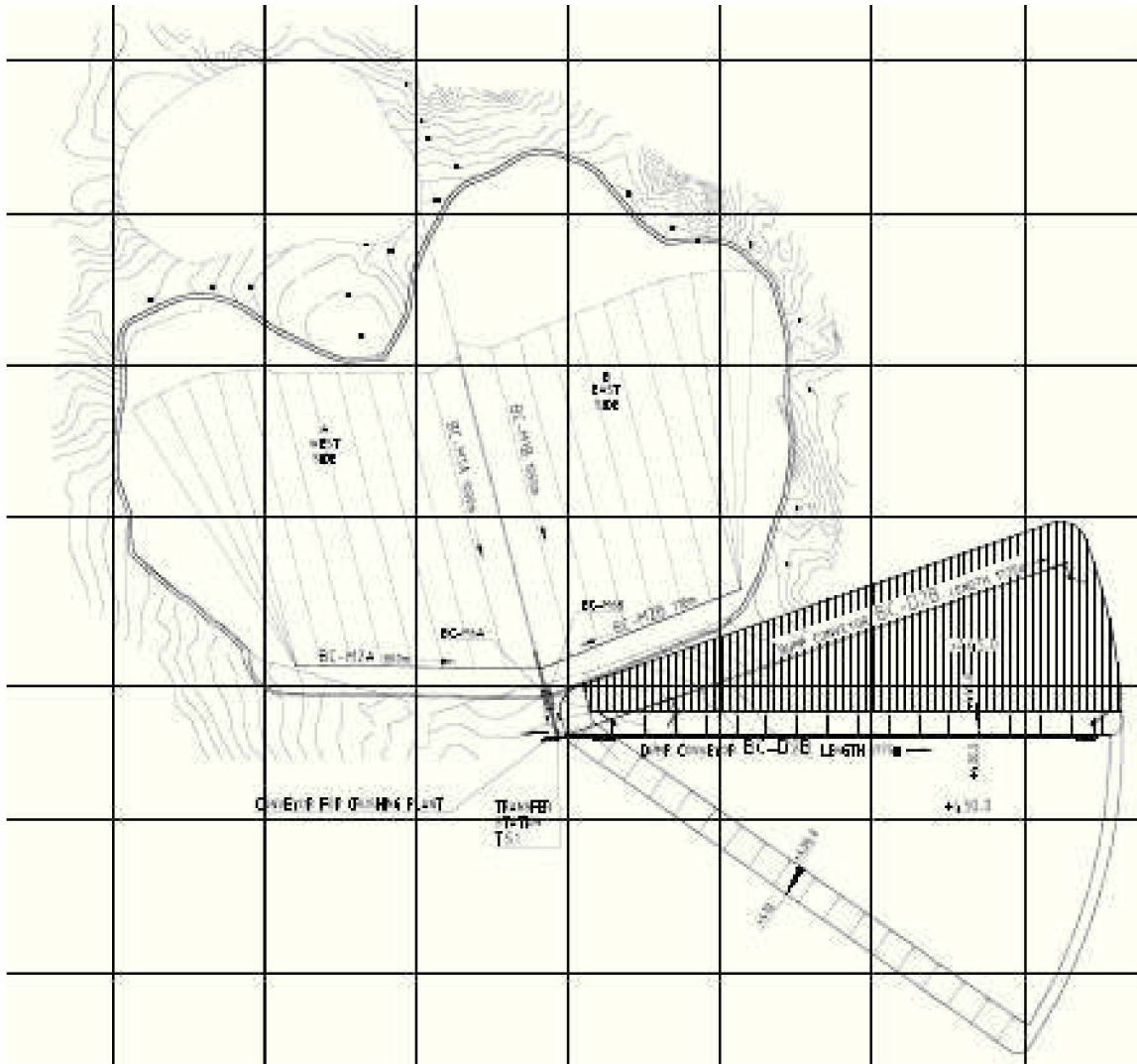

Fig. 5-5: Aktogai – Dump yard in year 2

Stage 3 – 3rd year

In the 3rd stage it continues the advance in slewing operation and from now on in low cast and high cast (20 m + 20 m) and dumps overburden of approx. 100 Mlm³ until end of the 10th year and another 74 Mlm³ up to the end of mine life.

The development of the dump, particularly the relocation of the pivot points and the relocation of dump conveyors, tripper cars and spreaders from surface to the + 20 m level is a complicated matter. This is described in detail afterwards.

5.1.4. Dump Area

The dump area occupies 2.5 km² and 40 m height. It forms a half-circle with 1.500 m radius. This is the length of the shiftable dump conveyors. The overland conveyors between the shuttle heads of the lifting Conveyors BC-M3A and BC-M3B are 600 m (BC-D1A) and 700 m (BC-D1B) long to the first pivot points and 700 m and 830 m respectively to the new and final pivot points.

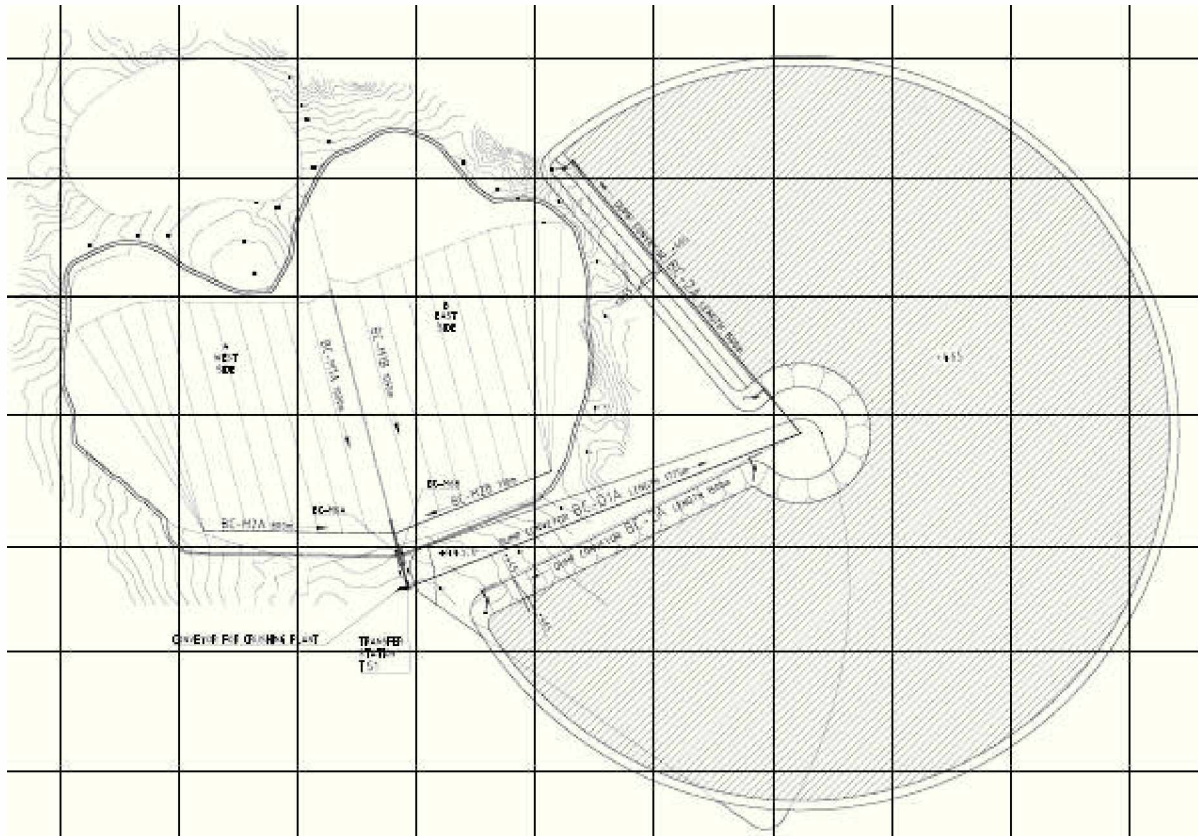

Fig. 5-6: Aktogai – Dump yard in year 3 to 32

Sequence of Conveyor/Spreader System A – 1st and 2nd Years

The pivot points for the spreaders are located so that their relocation in year 2 does not interfere with the other system and the other dump (System B). The sequence is illustrated in Fig. 5–7: Aktogai – Layout of conveyors at the beginning.

1st Phase

- Prepare tracks of overland conveyor BC – D1A and BC – D1B and dump conveyor BC – D2A and BC – D2B on surface (+410 m level)
- Install conveyors and first pivot point (+410 m)
- Install tripper car and spreader on surface level (+410 m) – (Fig. 5–8: Aktogai – Layout of Dump Area at 1st phase)

2nd Phase

- Start dump of overburden in 20 m height leaving space of 10 m between dump toe and dump conveyor BC – D2A (Fig. 5–8: Aktogai – Layout of Dump Area at 1st phase)
- Continue dumping of overburden in slewing advance up to end position at end of year 1 with a total of 25 Ml^m³

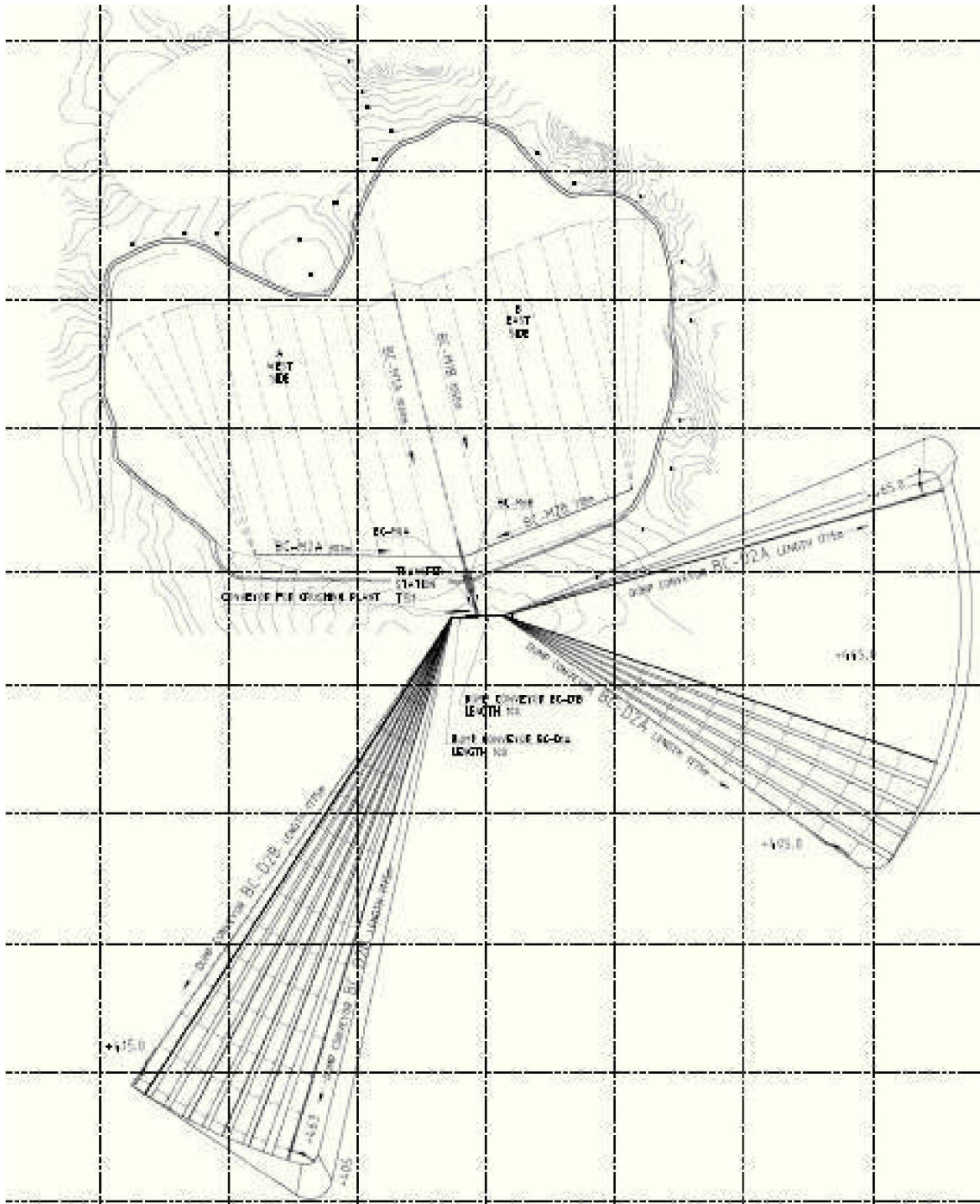

P750-PLANT-LAYOUT-Y1-18Aug2006

Fig. 5-7: Aktogai – Layout of conveyors at the beginning

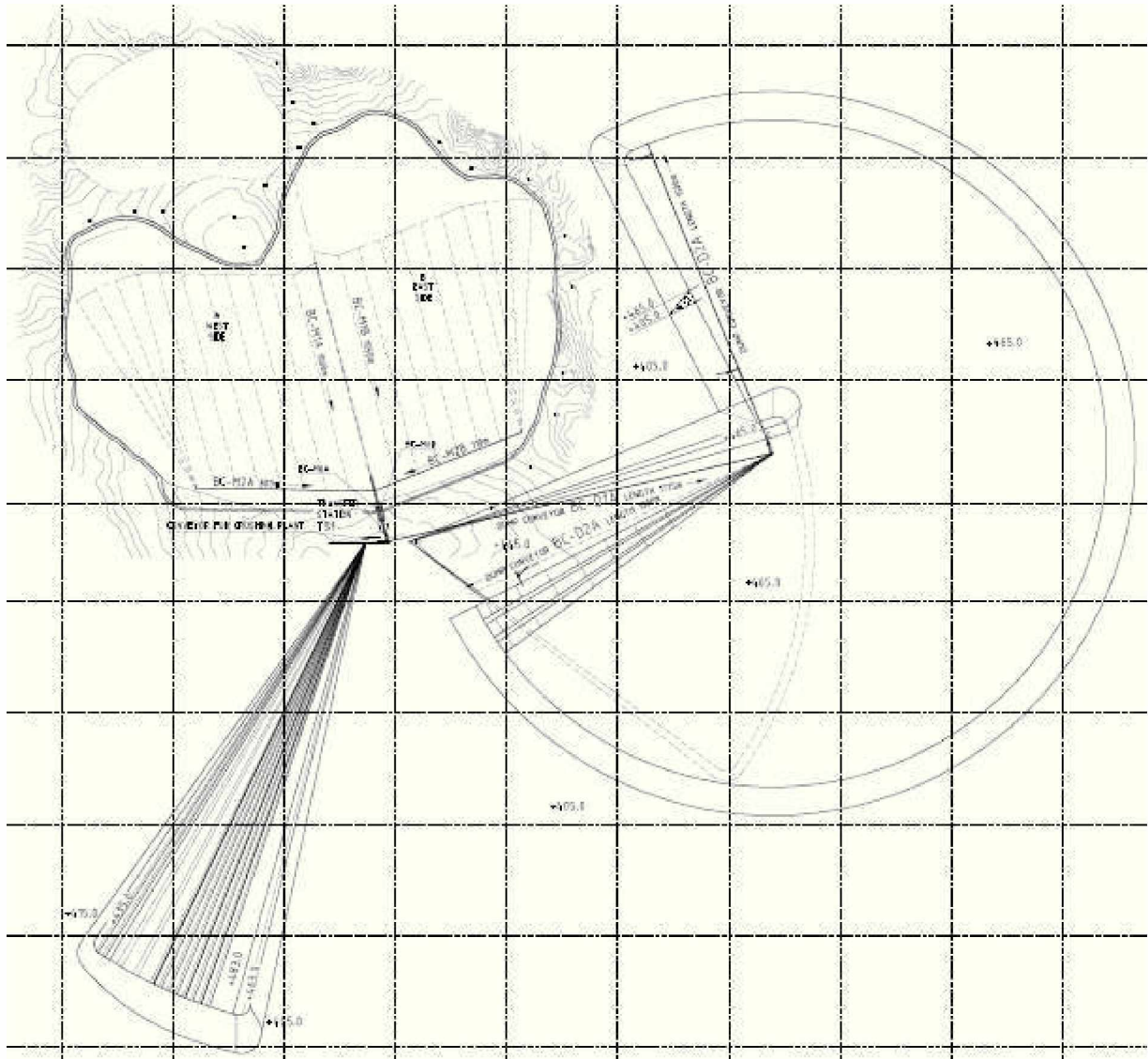

Figure 5-1: 1st phase
P750-PLANT-LAYOUT-Y3-18Aug2006

Fig. 5-8: Aktogai - Layout of Dump Area at 1st phase

3rd Phase

- Move drive head station of overland conveyor (BC-D1A) back by 25 m
- Shift dump conveyor (BC-D2A) back by 25 m
- Doze down the slope towards the dump conveyor, inclination 5:1, leave space between toe and dump conveyor of 10 m
- Doze access ramp 10:1 at dump end for spreader up to + 20 m (+430 m level)

4th Phase

- Park tripper car at the tail end of the dump conveyor (+410 m)
- Shift the conveyor (BC-D2A) including the flat drive head station up the slope at the head end into a diagonal position between surface (+410 m) at the tail end and + 20 m at the head end (+430 m)
- Move the tripper car along the conveyor from surface to + 20 m at the head end (inclination about 60:1)
- Shift the conveyor at the tail end up the slope to + 20 m level (+430 m)
- Move the drive head station of the overland conveyor (BC-D1A) from surface level up to the new pivot point on + 20 m level (+430 m)
- Extend the overland conveyor and connect it at the new pivot point with the shiftable dump conveyor on +20 m level (+430 m)
- Prepare starting platform of spreader on + 20 m level and access ramp 10:1
- Move the spreader into start position on + 20 m level (+430 m).



5th Phase

- Regular dump operation of oxidic ore near the pivot point and of waste at the outer side with 20 m high cast in slewing advance up to end position at end of 2nd year with a total of 25 Ml m^3 .

5.2. Equipment description

In this chapter, all units and the equipment for the “*New continuous mining system for hard rock application*” in the copper mine Aktogai in Kazakhstan is described.

5.2.1. Drilling equipment

The whole drilling equipment consists of the following elements:

- 6 surface drilling rigs Type 1190E

The Sandvik surface drilling rig Type 1190E is an electrically powered, self-propelled crawler mounted blast-hole drill for mining. The electric motor has an output about 850 HP at 1.800 RPM. It is equipped to rotary drill (229 to 381 mm) diameter holes. Maximum pulldown is 400 kN (bit load 523 kN). The mast raises or lowers in less than a minute. Coupled with great slewing power and visibility, this assures good hole spotting and productivity. Its heavy duty undercarriage maximizes stability. There are also coolers installed for up to 130°F (54°C) ambient temperature.

These machines are built for continuous drilling in some of the harshest operating environments in the world. Proven designs, heavy duty pulldown chains, and durable power plants, place these rigs in a class of their own.



Fig. 5–9: Sandvik surface drilling rig Type 1190E

5.2.2. Loading

The whole loading equipment consists of the following elements:

- 2 rope shovel excavator P&H 4100 XPB
- 3 wheel loader LeTourneou L-2350

The drilled and blasted material gets taken to the mobile crusher by 2 rope shovel excavator P&H 4100 XPB and 3 wheel loader LeTourneou L-2350.

The rope shovel excavator P&H 4100 XPB is one of the biggest excavators in the world.



Fig. 5-10: Rope shovel excavator P&H 4100 XPB

The excavator has a nominal payload capacity of about 115 tons and a dipper capacity range from 35,9 m³ up to 76,5 m³. The maximum height of cut is about 18,06 m and the maximum radius of cut is 23,80 m. The maximum dumping height is 10,44 m.

The whole rope shovel excavator is electrically powered with 6.000, 6.600 or 11.000 V at 50 Hz.

The overall width is 14,35 m, the overall length is 14,33 m. The working weight averages 1.435 tons inclusive dipper.

The wheel loader LeTourneou L-2350 is one of the biggest loader in the world too.



Fig. 5-11: Wheel loader LeTourneou L-2350

The bucket capacity is about 53 yd³ (40,52 m³) and has a operating payload of about 72.574 kg. The L-2350 has an operating weight of 262 tons. With a fully raised bucket the height is about 13,33 m and the overall bucket length about 20,16 m.

The loader has a 4-cycle turbocharged diesel engine with 1.715kW at 1.900 RPM and 16 cylinders. The wheel loader LeTourneou L-2350 has a travelling speed maximum of 16,9 Kph.

For the operator, the L-2350 has a spacious, ergonomically designed operator's cab featuring a low interior sound level. The cab is mounted directly over the center articulation point, providing excellent visibility. The operator has a joystick for steering and bucket control.

5.2.3. Crushing system

The whole crushing system consists of the following elements:

- 2 mobile crushing plants by MMD Type 1500

For crushing the blasted material, a crushing system is essential. For this task, 2 mobile crusher plants by MMD Type 1500 with a slewable discharge boom crusher will be used. The shaft centers are about 1.500mm. The height of the sizer is 1.800 mm, the width about 4.050 mm and the length about 10.100 mm. For feeding the sizer with material, the inlet dimensions are 1.200 mm long and 3.200 mm width. The Sizer has a weight about 190 tonnes.

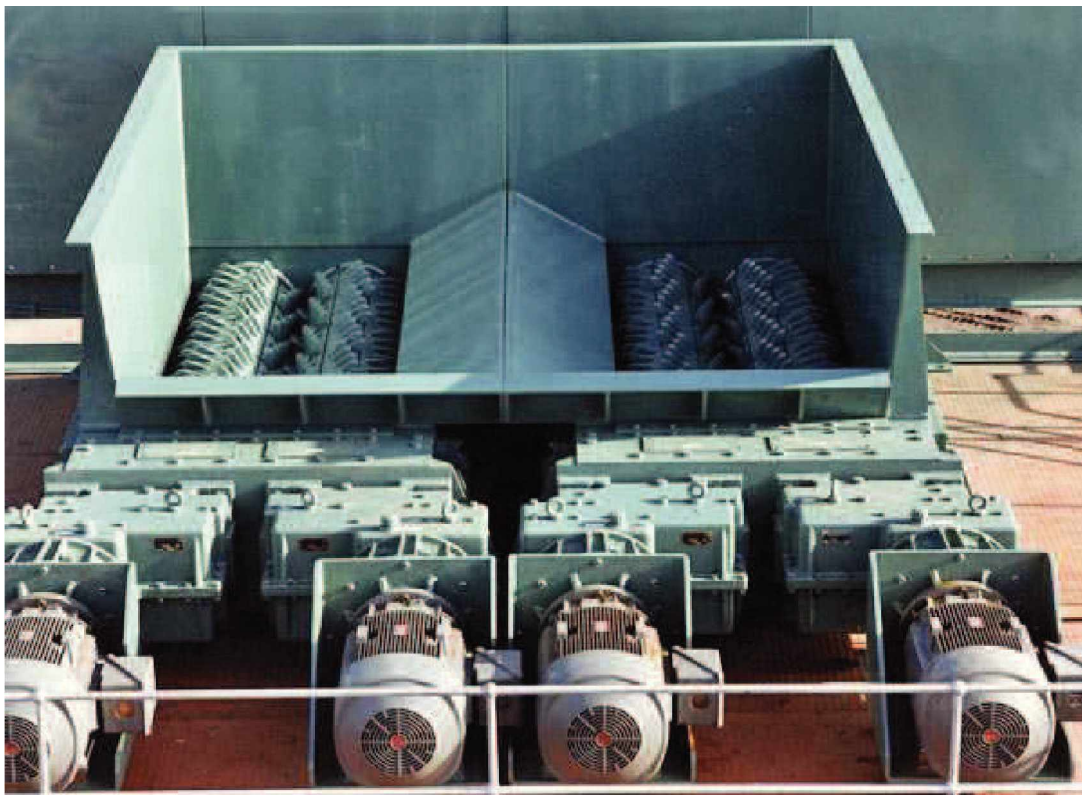

Fig. 5-12: Inlet port of the fully mobile crusher by MMD Type 1500

The MMD 1500 sizer has a lot of features. There is a modular ribbed robust mainframe, high strength alloy steel shafts for crushing. There is also a fluid coupling that allows start-up and affords torque protection to the machine and a shock loading resistant - robust modular gearbox with high torque capacity.

This crushing unit has a processing rate up to 10.000 t/h that is used for the process in the pit.



Fig. 5-13: MMD mobile crusher plant Type 1500

After crushing and sizing the material in this unit, the material drops onto a conveying belt that is connected with a belt wagon with 2 liftable booms.

5.2.4. Equipment of mine conveyor system

The whole mine conveyor system consists of the following elements:

- 2 Belt wagon Type VABW 1800/40+45

This belt wagon has a nominal capacity of 8.000 t/h and a maximal capacity of 9.600 t/h. The belt width is 1.800 mm.

All following units have the same technical data as this belt wagon.

The length of the receiving boom is 40 m, the length of the discharging boom is 45 m. The belt wagon weighs about 638.000 kg and gets powered by a 1.400 kW motor.

- 2 Hopper and Cable Drum Type VAHCC 1800

This hopper and cable drum is used for storing the power cables for the electric power units and has a travel length of approximately 1.200m and a rail gauge of 3.5 m. The hopper and cable drum weighs about 60.000 kg and gets powered by a 100 kW motor.

- 1 Face Conveyor BC-M1A Type VABCS 1800

The conveyor BC-M1A is the first conveyor in the mine. It has a length of 1.200 m and is shiftable. The conveyor BC-M1A weighs about 1.240.000 kg and gets powered by a 1.800 kW motor.

- 1 Face Conveyor BC-M1B Type VABCS 1800

The conveyor BC-M1B is the other first conveyor in the mine. It has a length of 1.000 m and is shiftable. The conveyor BC-M1B weighs about 1.060.000 kg and gets powered by a 1.800 kW motor.



- 1 Run of Mine Conveyor BC-M3A Type VABCS 1800
(with transfer station)
The conveyor BC-M3A has a length of 300 m and is stationary. The conveyor BC-M3A weighs about 795.000 kg and gets powered by a 900 kW motor.
- 1 Run of Mine Conveyor BC-M3B Type VABCS 1800
(with transfer station)
The conveyor BC-M3B has a length of 300 m and is stationary. The conveyor BC-M3B weighs about 795.000 kg and gets powered by a 900 kW motor.
- 1 Bench connecting Conveyor BC-M2A Type VABCS 1800
The conveyor BC-M2A has a length of 800 m and is replaceable. The conveyor BC-M2A weighs about 295.000 kg and gets powered by a 900 kW motor.
- 1 Bench connecting Conveyor BC-M2B Type VABCS 1800
The conveyor BC-M2B has a length of 800 m and is replaceable too. The conveyor BC-M2B weighs about 295.000 kg and gets powered by a 900 kW motor.
- 1 Lift Conveyor BC-M3A Type VABCS 1800
The conveyor BC-M3A has a length of 660 m and is extendable. The conveyor BC-M3A weighs about 1.170.000 kg and gets powered by a 5.000 kW motor.



- 1 Lift Conveyor BC-M3B Type VABCS 1800

The conveyor BC-M3B has a length of 660 m and is extendable too. The conveyor BC-M3B weighs about 1.170.000 kg and gets powered by a 5.000 kW motor.

6. Comparison of the operating costs

Comparison of the operating costs of a belt conveyor and one or more haulage trucks for an open pit mine with an inclination of max. 14 % for the belt conveyor system and max. 3 % for the haulage trucks.

General data:

Costs / litre for diesel:

0,75 €/l

Costs for electric energy:

~ 0,05 €/kWh

Basic data of the mine:

Nominal mass flow:

8.000 t/h

Driving routes for the comparison:

Example 1 – 600 m

Example 2 – 1.500 m

Example 3 – 2.500 m

Example 4 – 5.000 m

Example 1: Length of the whole belt conveyor system and the driving route for the trucks is 600 m

Operating costs of the truck for a driving route of 600 m

Costs for fuel per year

Consumption:	50.00 l/h
Consumption:	2.160.000 l/a
Price / litre:	0.75 €/l
Costs for fuel per year:	1.620.000 €/a

Costs for personal

Number of drivers:	11
Number of trucks in action:	5
Costs for a driver per month:	2.000 €/Mt
Number of payments per year:	14
Personal costs per year:	308.000 €/a
<u>Staff for maintenance:</u>	<u>135.000 €/a</u>
Costs for driver per year:	443.000 €/a

Costs for maintenance

Costs for sweeping the street:	300.000 €/a
Costs for spare parts (oil, etc.)	200.000 €/a
Tyres:	500.000 €/a
Costs for maintenance per year:	1.000.000 €/a

Total costs of the truck per year

Costs for fuel per year:	1.620.000 €/a
Costs for driver per year:	443.000 €/a
<u>Costs for maintenance per year:</u>	<u>1.000.000 €/a</u>
Total operating costs:	3.063.000 €/a

Operating costs of the belt conveyor system

Maintenance costs

The annual costs for maintenance are about 3 % of the purchase price.
And therefore:

Purchase price:	2.600.000 €
Annual costs for maintenance (3%)	78.000 €/a

Energy costs

Required power:	900 kW
Annual work time:	8.640 h/a
Annual energy consumption:	8.553.600 kWh/a
Working price for electricity:	0.05 €/kWh
Energy costs per year:	427.680 €/a
<u>Power net connection costs per year:</u>	<u>384.912 €/a</u>
Total costs for electric power per year:	812.592 €/a

Total operating costs

Total costs of the belt conveyor:	78.000 €/a
<u>Energy costs per year:</u>	<u>812.592 €/a</u>
Total operating costs per year	890.592 €/a

Comparison of the annual costs

Truck	3.063.000 €/a
Belt conveyor	890.592 €/a

The total costs for operating the belt conveyor system is about 29,1 % of the total operating costs of the haulage trucks.

Example 2: Length of the whole belt conveyor system and the driving route for the trucks is 1.500 m

Operating costs of the truck for a driving route of 1.500 m

Costs for fuel per year

Consumption:	50.00 l/h
Consumption:	3.024.000 l/a
Price / litre:	0.75 €/l
Costs for fuel per year:	2.268.000 €/a

Costs for personal

Number of drivers:	16
Number of trucks in action:	7
Costs for a driver per month:	2.000 €/Mt
Number of payments per year:	14
Personal costs per year:	448.000 €/a
<u>Staff for maintenance:</u>	<u>135.000 €/a</u>
Costs for driver per year:	583.000 €/a

Costs for maintenance

Costs for sweeping the street:	300.000 €/a
Costs for spare parts (oil, etc.)	200.000 €/a
<u>Tyres:</u>	<u>700.000 €/a</u>
Costs for maintenance per year:	1.200.000 €/a

Total costs of the truck per year

Costs for fuel per year:	2.268.000 €/a
Costs for driver per year:	583.000 €/a
<u>Costs for maintenance per year:</u>	<u>1.200.000 €/a</u>
Total operating costs:	4.051.000 €/a

Operating costs of the belt conveyor system

Maintenance costs

The annual costs for maintenance are about 3 % of the purchase price.
And therefore:

Purchase price:	5.300.000 €
Annual costs for maintenance (3%)	159.000 €/a

Energy costs

Required power:	1.800 kW
Annual work time:	8.640 h/a
Annual energy consumption:	17.107.200 kWh/a
Working price for electricity:	0.05 €/kWh
Energy costs per year:	855.360 €/a
<u>Power net connection costs per year:</u>	<u>769.824 €/a</u>
Total costs for electric power per year:	1.625.184 €/a



Total operating costs

Total costs of the belt conveyor:	159.000 €/a
<u>Energy costs per year:</u>	<u>1.625.184 €/a</u>
Total operating costs per year	1.784.184 €/a

Comparison of the annual costs

Truck	4.051.000 €/a
Belt conveyor	1.784.184 €/a

The total costs for operating the belt conveyor system is about 44,0 % of the total operating costs of the haulage trucks.

Example 3: Length of the whole belt conveyor system and the driving route for the trucks is 2.500 m

Operating costs of the truck for a driving route of 2.500 m

Costs for fuel per year

Consumption:	50.00 l/h
Consumption:	4.320.000 l/a
<u>Price / litre:</u>	<u>0.75 €/l</u>
Costs for fuel per year:	3.240.000 €/a

Costs for personal

Number of drivers:	22
Number of trucks in action:	10
Costs for a driver per month:	2.000 €/Mt
Number of payments per year:	14
Personal costs per year:	616.000 €/a
<u>Staff for maintenance:</u>	<u>135.000 €/a</u>
Costs for driver per year:	751.000 €/a

Costs for maintenance

Costs for sweeping the street:	500.000 €/a
Costs for spare parts (oil, etc.)	200.000 €/a
<u>Tyres:</u>	<u>1.000.000 €/a</u>
Costs for maintenance per year:	1.700.000 €/a

Total costs of the truck per year

Costs for fuel per year:	3.240.000 €/a
Costs for driver per year:	751.000 €/a
<u>Costs for maintenance per year:</u>	<u>1.700.000 €/a</u>
Total operating costs:	5.691.000 €/a

Operating costs of the belt conveyor system

Maintenance costs

The annual costs for maintenance are about 3 % of the purchase price.

And therefore:

Purchase price:	8.300.000 €
Annual costs for maintenance (3%)	249.000 €/a

Energy costs

Required power:	6.250 kW
Annual work time:	8.640 h/a
Annual energy consumption:	59.400.000 kWh/a
Working price for electricity:	0.05 €/kWh
Energy costs per year:	2.970.000 €/a
<u>Power net connection costs per year:</u>	<u>2.673.000 €/a</u>
Total costs for electric power per year:	5.643.000 €/a

Total operating costs

Total costs of the belt conveyor:	249.000 €/a
<u>Energy costs per year:</u>	<u>5.643.000 €/a</u>
Total operating costs per year	5.892.000 €/a

Comparison of the annual costs

Truck	5.691.000 €/a
Belt conveyor	5.892.000 €/a

The total costs for operating the belt conveyor system is about 103,5 % of the total operating costs of the haulage trucks.

Example 4: Length of the whole belt conveyor system and the driving route
for the trucks is 5.000 m

Operating costs of the truck for a driving route of 5.000 m

Costs for fuel per year

Consumption:	50.00 l/h
Consumption:	6.048.000 l/a
Price / litre:	0.75 €/l
Costs for fuel per year:	4.536.000 €/a

Costs for personal

Number of drivers:	31
Number of trucks in action:	14
Costs for a driver per month:	2.000 €/Mt
Number of payments per year:	14
Personal costs per year:	868.000 €/a
<u>Staff for maintenance:</u>	<u>135.000 €/a</u>
Costs for driver per year:	1.003.000 €/a

Costs for maintenance

Costs for sweeping the street:	500.000 €/a
Costs for spare parts (oil, etc.)	200.000 €/a
<u>Tyres:</u>	<u>1.400.000 €/a</u>
Costs for maintenance per year:	2.100.000 €/a

Total costs of the truck per year

Costs for fuel per year:	4.536.000 €/a
Costs for driver per year:	1.003.000 €/a
<u>Costs for maintenance per year:</u>	<u>2.100.000 €/a</u>
Total operating costs:	7.639.000 €/a

Operating costs of the belt conveyor system

Maintenance costs

The annual costs for maintenance are about 3 % of the purchase price.

And therefore:

Purchase price:	9.500.000 €
Annual costs for maintenance (3%)	285.000 €/a

Energy costs

Required power:	7.700 kW
Annual work time:	8.640 h/a
Annual energy consumption:	73.180.800 kWh/a
Working price for electricity:	0.05 €/kWh
Energy costs per year:	3.659.040 €/a
<u>Power net connection costs per year:</u>	<u>3.293.136 €/a</u>
Total costs for electric power per year:	6.952.176 €/a

Total operating costs

Total costs of the belt conveyor:	285.000 €/a
<u>Energy costs per year:</u>	<u>6.952.176 €/a</u>
Total operating costs per year	7.237.176 €/a

Comparison of the annual costs

Truck	7.639.000 €/a
Belt conveyor	7.237.176 €/a

The total costs for operating the belt conveyor system is about 94,7 % of the total operating costs of the haulage trucks.

Examples 1 to 4 show, that the operating costs of a belt conveyor system in comparison to haulage trucks are at the beginning very strong rising and than staying at a point. This point depends on the prices for electric motors.

That means that a belt conveyor system is better, cheaper and more efficient but not so flexible for longer distances in regard to the costs for haulage trucks. It is very important to say, that all these prices and costs are only operating costs. There are no purchase prices for haulage trucks included in the comparison.

In Fig. 6-1 (Diagram of the comparison of the 4 examples of continuous and not continuous conveying methods) the results of the 4 examples of the different operating costs between haulage trucks and a belt conveyor system are shown. It can be seen that the costs for the 4 examples vary between 29,1 % and 103,5 % in dependence to the total conveying length.

	Total conveying length [m]	Operating costs for haulage trucks [€]	Operating costs for a belt conveyor system [€]	Ratio of the operating costs of the belt conveyor system and haulage trucks [%]
Example 1:	600	3.063.000,00	890.592,00	29,1
Example 2:	1500	4.051.000,00	1.784.184,00	44,0
Example 3:	2500	5.691.000,00	5.892.000,00	103,5
Example 4:	5000	7.159.000,00	7.342.176,00	94,7

Fig. 6-1: Comparison of the operating costs of the 4 examples of continuous and discontinuous conveying methods

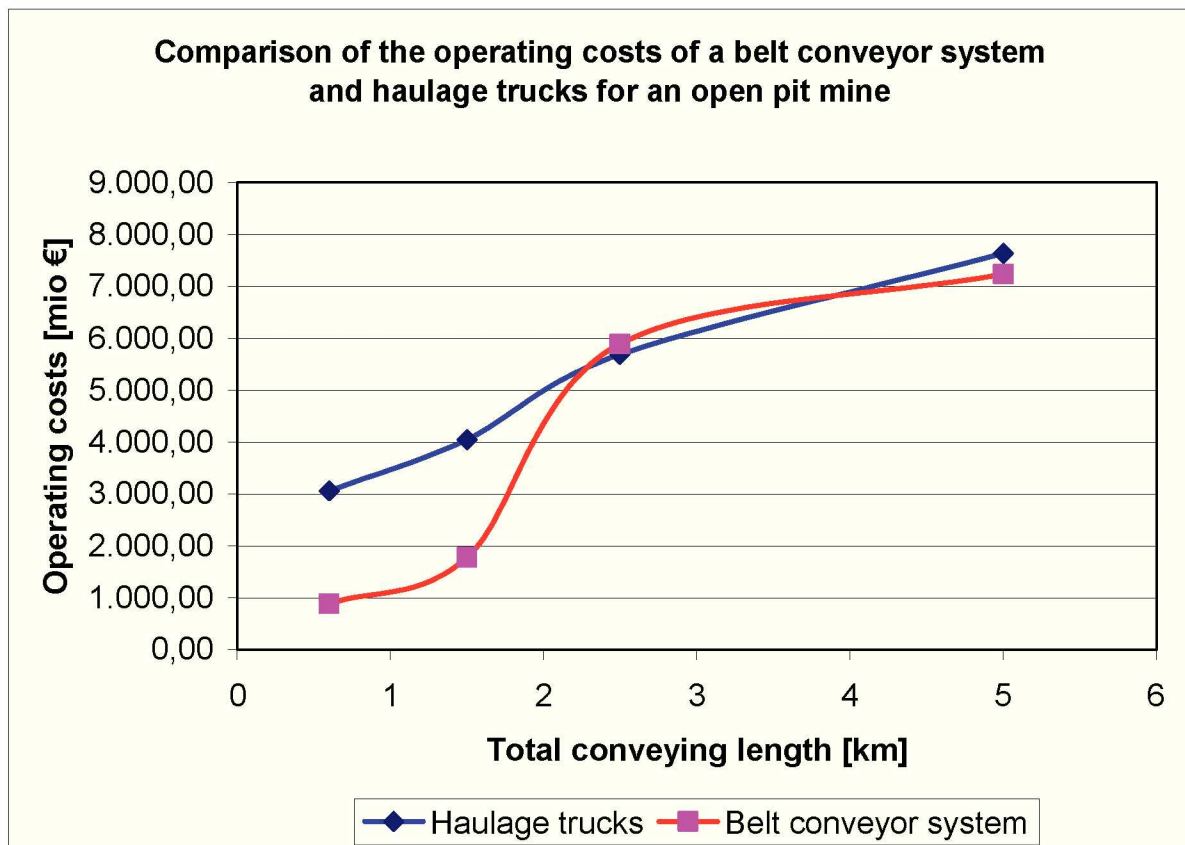

Fig. 6-2: Diagram of the comparison of the 4 examples of continuous and discontinuous conveying methods

Fig. 6–2 (Diagram of the comparison of the 4 examples of continuous and discontinuous conveying methods) shows that the operating costs of a set of haulage trucks increase continuously by the number of trucks and drivers. The trucks need for operation always the same amount of fuel per hour, independent if they drive loaded or without any load. So, half time of the work, they drive without any load.

The belt conveyor system works without any personal, whole day and night. The longer the belt, the bigger must the installed electric motors be. So it can be seen, that the operating costs of a belt conveyor system depend on the size of the installed electric power units and on the length of the belt.

7. Conclusion

In the diploma thesis "*New continuous mining system for hard rock application*", the three conventional mining systems for open-pit mining have been described and compared.

A "*New continuous mining system for hard rock application*" had to be developed and described from the three conventional mining systems.

It can be seen, that the new mining system fulfills the qualifications for reducing the amount of personnel and reducing the operating costs by using belt conveyors instead of trucks. Chapter 6 "Comparison of the operating costs" shows, that the ratios of the operating costs of the belt conveyor system and haulage trucks of the 4 compared examples vary between 29,1 % and 103,5 % in dependence to the total conveying length. The operating costs for a set of haulage trucks increase continuously by the number of trucks and drivers. The belt conveyor systems work without any drivers, they only need a maintenance group. The operating costs depend mainly on the length and dimensions of the belt and on the nominal mass flow.

The "*New continuous mining system for hard rock application*" can be used for small, large and very large mines for mining soft rock and hard rock as well. The new system requires less personnel and conveying and is more efficient when conveying on longer distances.

8. Literature index

1. Vorlesungsskript zu „Fördertechnik 1“, Institut für Fördertechnik und Konstruktionslehre; Montanuniversität Leoben
2. Vorlesungsskript zu „Fördertechnik 2“, Institut für Fördertechnik und Konstruktionslehre; Montanuniversität Leoben
3. Vorlesungsskript zu „Fördertechnik 2“, Institut für Fördertechnik und Konstruktionslehre; Montanuniversität Leoben
4. Vorlesungsskript zu „Transportsysteme und Logistik“, Institut für Fördertechnik und Konstruktionslehre; Montanuniversität Leoben
5. „Technisch/wirtschaftlicher Vergleich der kontinuierlichen und diskontinuierlichen Schüttgutförderung“; Univ. Prof. DI. Dr. mont. Franz Kessler and DI. Peter Diethardt; Institut für Fördertechnik und Konstruktionslehre; Montanuniversität Leoben
6. „Tagebau“; Peyer, U. and Wilk, T.; 2005; Podszun Verlag
7. „Festgesteinstagebau“; Goergen; 1987
8. „Surface Mining“; Van Stetten; 1990
9. „Stacking Blending Reclaiming of Bulk Materials“; Wöhlbier, R.H.; 1977; Trans Tech Publications
10. „Coal Magazin“
11. „Surface Mining Magazin“
12. „Schüttgut fördern und lagern“; VDI Jahrestagung, VDI Bericht 1996
13. „Förder- und Lagertechnik“; Martin, Heinrich; 1994



14. „Bulk solids handling“; Woodcok, C. R.; 1988
15. “Belt Conveyors for Bulk Material”; 1997; Conveyor Equipment Manufacturers Association
16. www.worldcoal.org
17. www.worldoil.com
18. www.mining-technology.com
19. www.vamh.com
20. www.letourneau-inc.com
21. www.bucryrus.com
22. www.driltech.sandvik.com
23. www.liebherr.com
24. www.mmd.com
25. www.hitachi.com

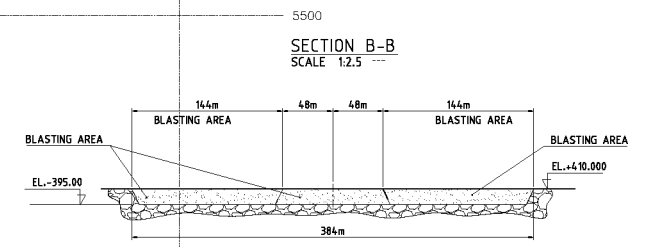

FOR BID PURPOSE ONLY

This drawing is not intellectual property; it must not be reproduced or transferred for or brought within the reach of third parties without written permission. Should the receiver be not allowed to use this drawing as a basis for manufacture/execution of the above conditions, will result in legal proceedings.

VEEST-ALPINE Materials Handling GmbH & Co KG ZELTWEIG

Released for manufacturing	
Date	15.12.25
Signature	
Manufacturer	Materials Handling
Project	36.07.2006 231
Checked	36.07.2006 CHR
Signer	
kg	
Material	
Quantity	
Unit	
Drawn	
Scale	
Sheet	
Rev	
0	1

THE KAZAKHMIY'S MINE
MINE BENCH DEVELOPMENT
(STAGE-1)

P750-AKTOGAI-MINE BENCH-1

Format: DIN A1

REFERENCES	DESCRIPTION	REVISIONS
used in :		
used in :		
used in :		
used in :		
used in :		
used in :		
used in :		
used in :		

BLAST THIS AREA BEFORE LAYING CONVEYORS

ALL LEVEL ARE IN METER.

SECTION A-A
SCALE 1:5

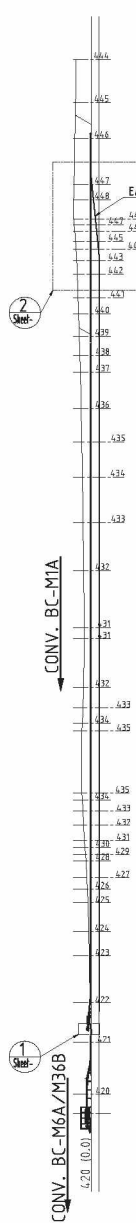

SECTION B-B
SCALE 1:2.5

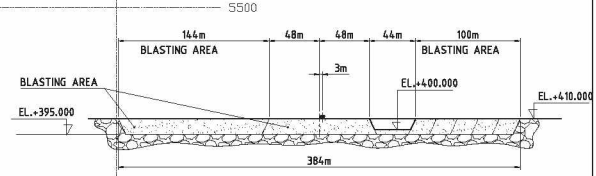

DETAIL 1
SCALE 1:0.25

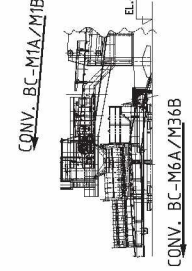

DETAIL 2
SCALE 1:1.5

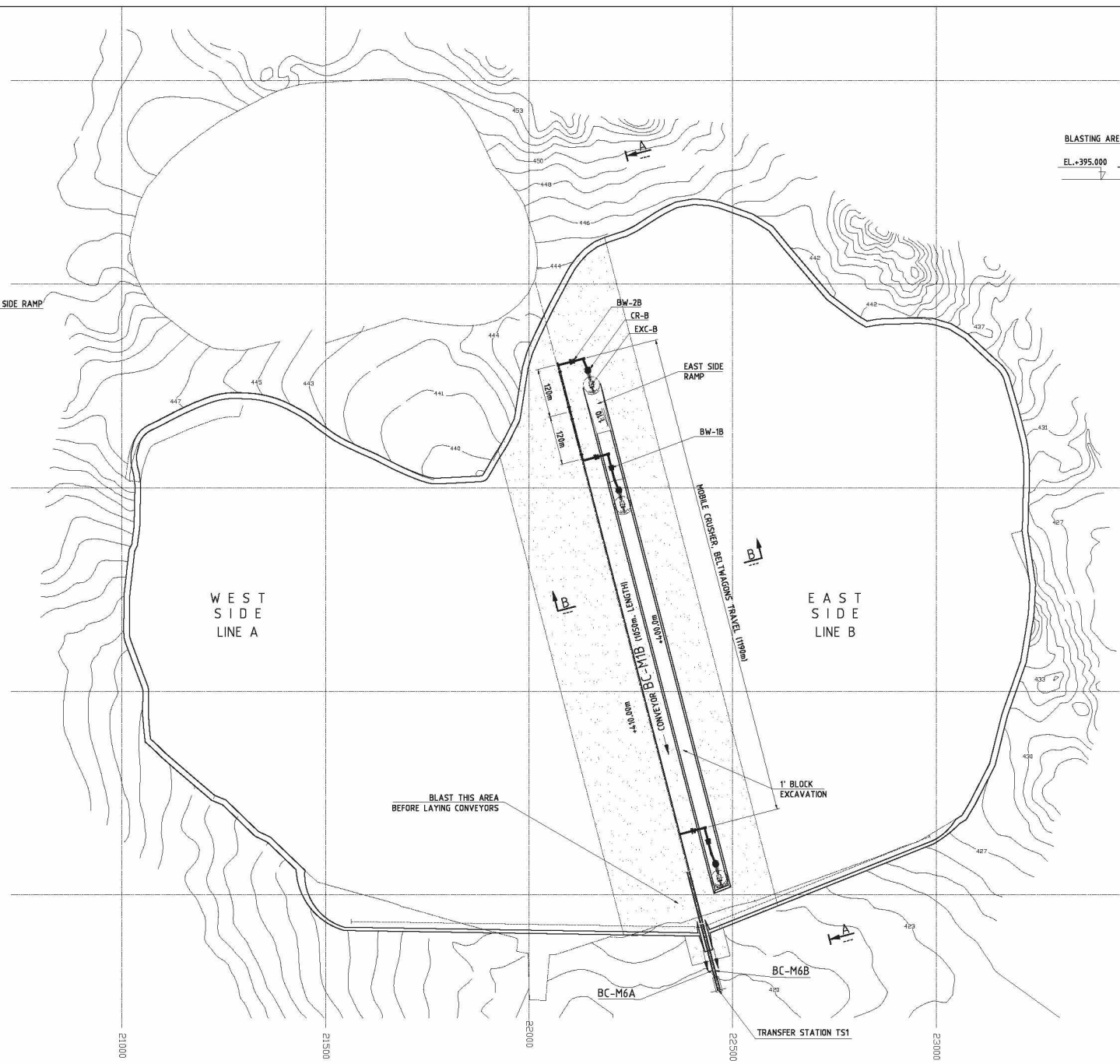
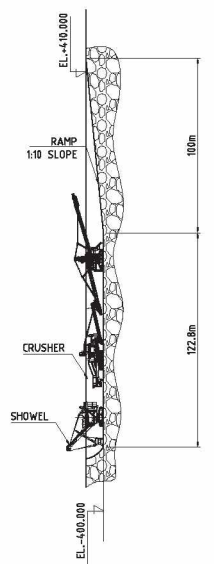

WEST SIDE
LINE A

EAST SIDE
LINE B

BLAST THIS AREA
BEFORE LAYING CONVEYORS

1' BLOCK
EXCAVATION

TRANSFER STATION TS1

FOR BID PURPOSE ONLY

ALL LEVEL ARE IN METER.

REFERENCES	DESCRIPTION	REVISIONS
used in :		
used in :		
used in :		
used in :		
used in :		
used in :		
used in :		

This drawing is an intellectual property that may be transferred or brought within the reach of third parties without our written permission. Likewise, the recipient is not allowed to use this drawing as a basis for manufacture. Violation of the above conditions will result in legal prosecution.

VOEST-ALPINE Materials Handling GmbH & Co KG ZILTWEG

Materials Handling

Designed	Date	Rev	1,5,12,5
Drawn	26.07.2006	AM	
Checked	26.07.2006	KPR	
Signat			kg
Dr./Date			

MINE BENCH DEVELOPMENT
(STAGE-2)

P750-AKTOGAI-MINE BENCH-2

0 1

Format DIN A1

SECTION B-B
SCALE 1:2.5
5500

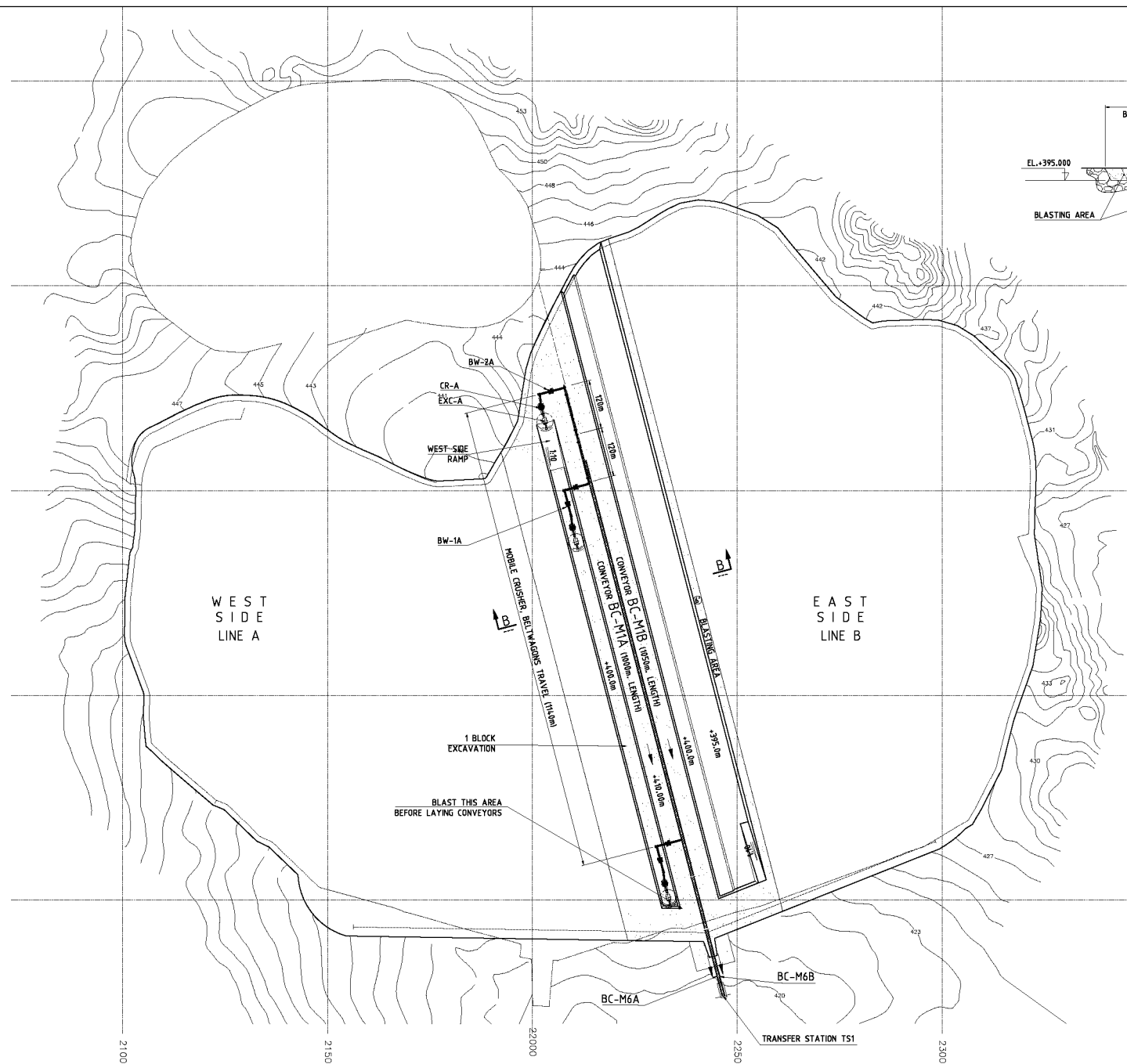
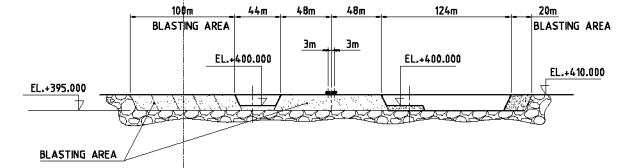

WEST SIDE LINE A

EAST SIDE LINE B

BLAST THIS AREA BEFORE LAYING CONVEYORS

FOR BID PURPOSE ONLY

This drawing is an intellectual property and may not be reproduced, stored, transmitted, or brought into the public domain without the express written permission of the creator. The creator is not allowed to use this drawing as a basis for manufacture. Violation of the above conditions will result in legal prosecution.			
VOEST-ALPINE Materials Handling GmbH & Co KG ZELTWEIG			
Manufacturer		Released for manufacturing	
Materials Handling		Date	15.12.5
voest-alpine		Drawn	AM
TMA KAZAKHSTAN MINE		Checked	CHR
MINE BENCH DEVELOPMENT		Scale	kg
(STAGE-4)		0	1
P750-AKTOGAI-MINE BENCH-4		Format: DIN A1	

REFERENCES	DESCRIPTION	REVISIONS
used in :		
used in :		
used in :		
used in :		
used in :		
used in :		
used in :		

ALL LEVEL ARE IN METER.

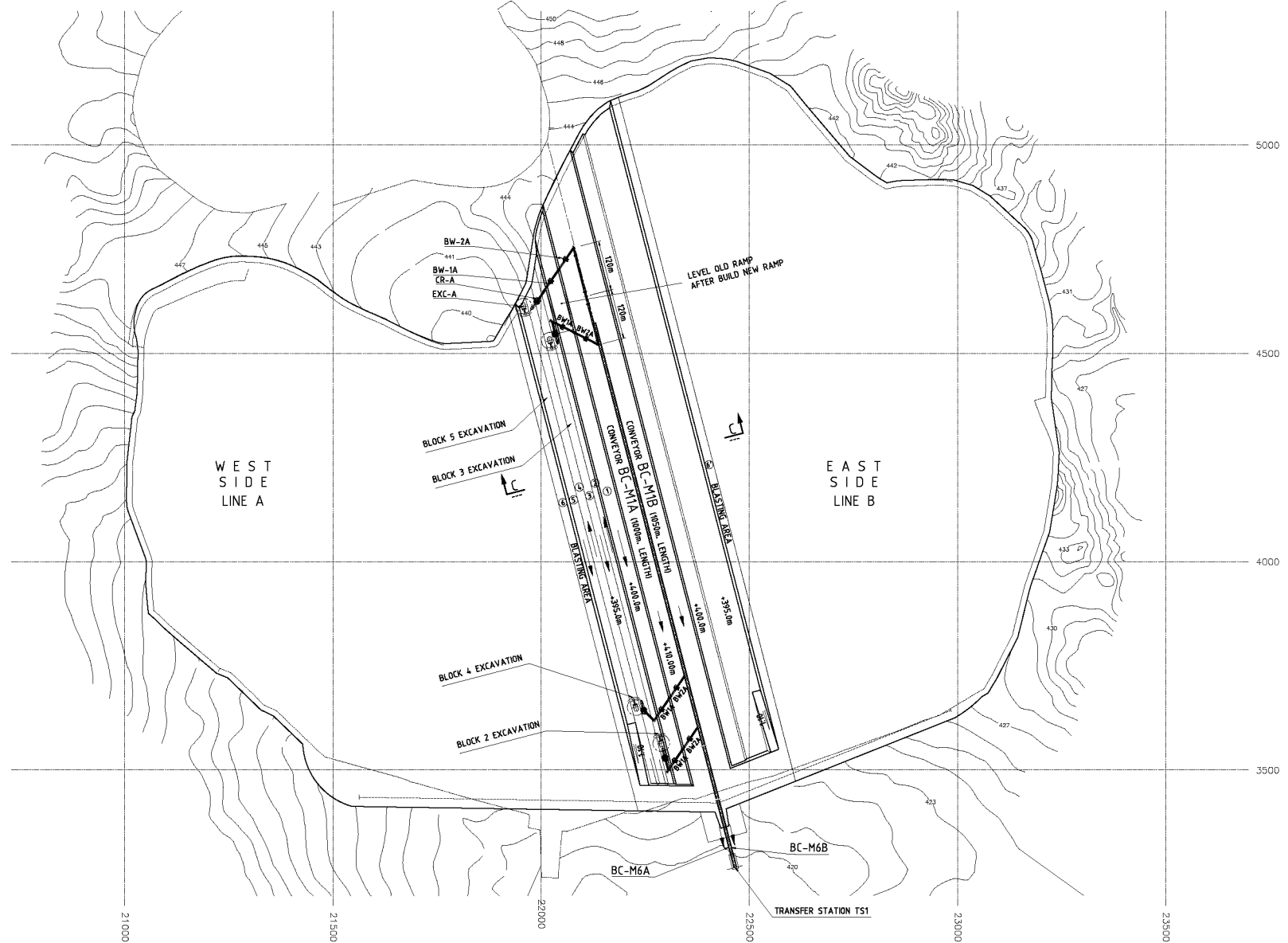
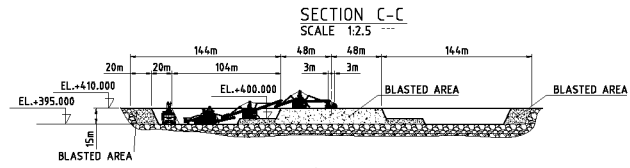

FOR BID PURPOSE ONLY

ALL LEVEL ARE IN METER.

REFERENCES	DESCRIPTION	REVISIONS
used in :		
used in :		
used in :		
used in :		
used in :		
used in :		
used in :		

This drawing is an intellectual property that may be transferred or brought within the reach of third parties without the written permission. Likewise, the contractor is not allowed to use this drawing as a basis for manufacture without the written permission of the above mentioned client.

VOEST-ALPINE Materials Handling GmbH & Co KG ZELTWEG

Released for manufacturing	
Date	Signature
Designed	Date
Drawn	Date
Checked	Date
Signed	Date
MINE BENCH DEVELOPMENT	
(STAGE-5)	
P750-AKTOGAI-MINE BENCH-5	kg
0	1

Format DIN A1

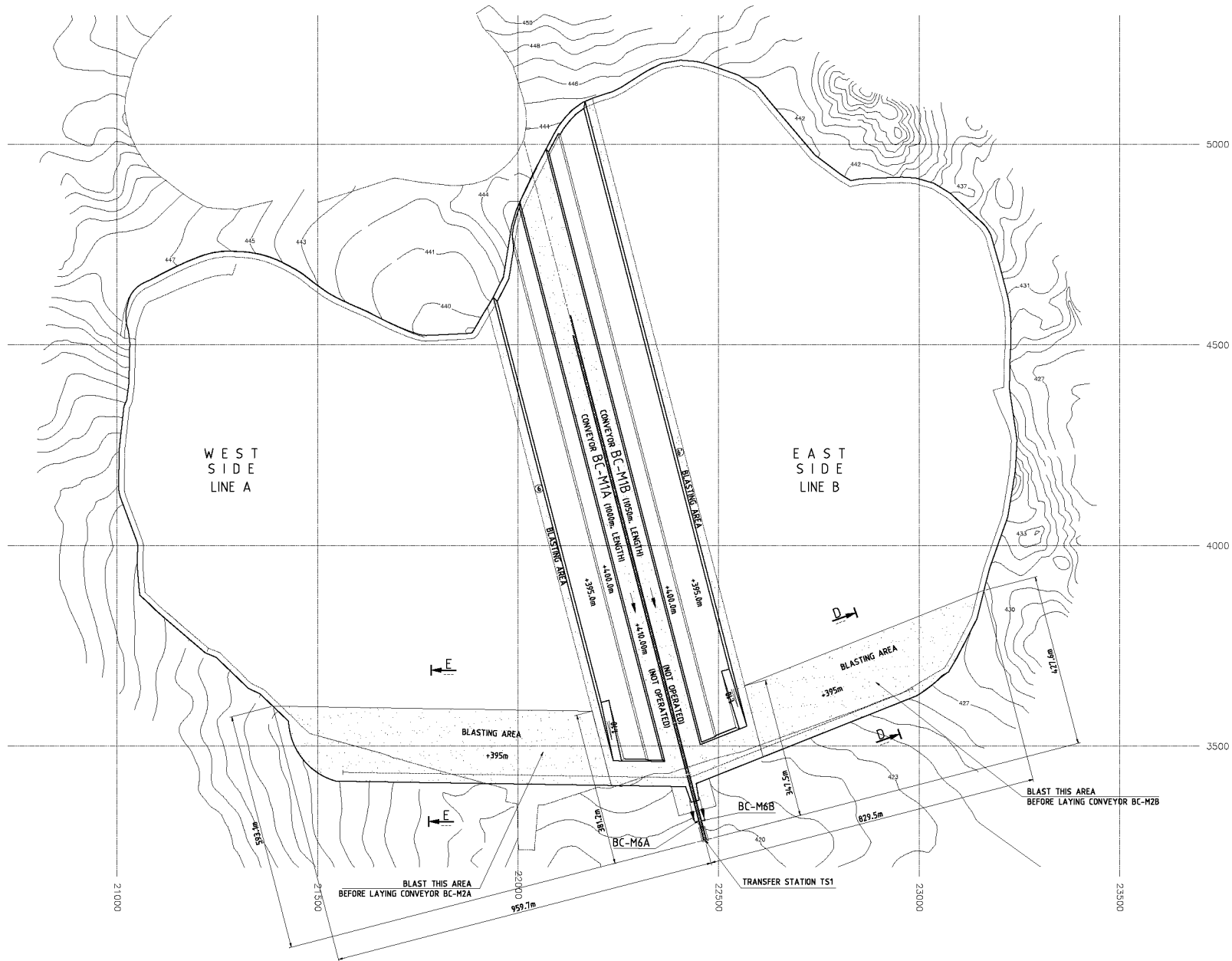

SECTION E-E
SCALE 1:2.5

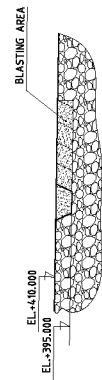

SECTION D-D
SCALE 1:2.5

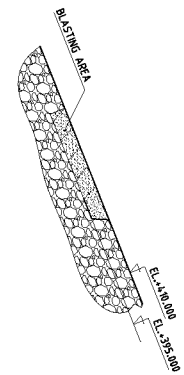

WEST
SIDE
LINE A

EAST
SIDE
LINE B

CONVEYOR BC-M1B (used, LENGTH)
CONVEYOR BC-M1A (under, LENGTH)
CONVEYOR BC-M6B (used, LENGTH)
CONVEYOR BC-M6A (NOT OPERATED, LENGTH)

BLAST THIS AREA
BEFORE LAYING CONVEYOR BC-M2A

TRANSFER STATION TS1

BLAST THIS AREA
BEFORE LAYING CONVEYOR BC-M2B

ALL LEVEL ARE IN METER.

FOR BID PURPOSE ONLY

REFERENCES	DESCRIPTION	REVISIONS
used in :		
used in :		
used in :		
used in :		
used in :		
used in :		
used in :		

This drawing is an intellectual property and may not be transferred or brought within the reach of third parties without the written permission. Likewise, the material is not allowed to be used for manufacturing. Violation of the above conditions will result in legal prosecution.
VOEST-ALPINE Materials Handling GmbH & Co KG ZELTWEG

THE KAZAKHSTAN MINE
MINE BENCH DEVELOPMENT
(STAGE-6)

Released for manufacturing

Drawn	26.07.2006	AM
Checked	26.07.2006	KHR

kg

0 1

Format: DIN A1

SECTION E-E
SCALE 1:2.5

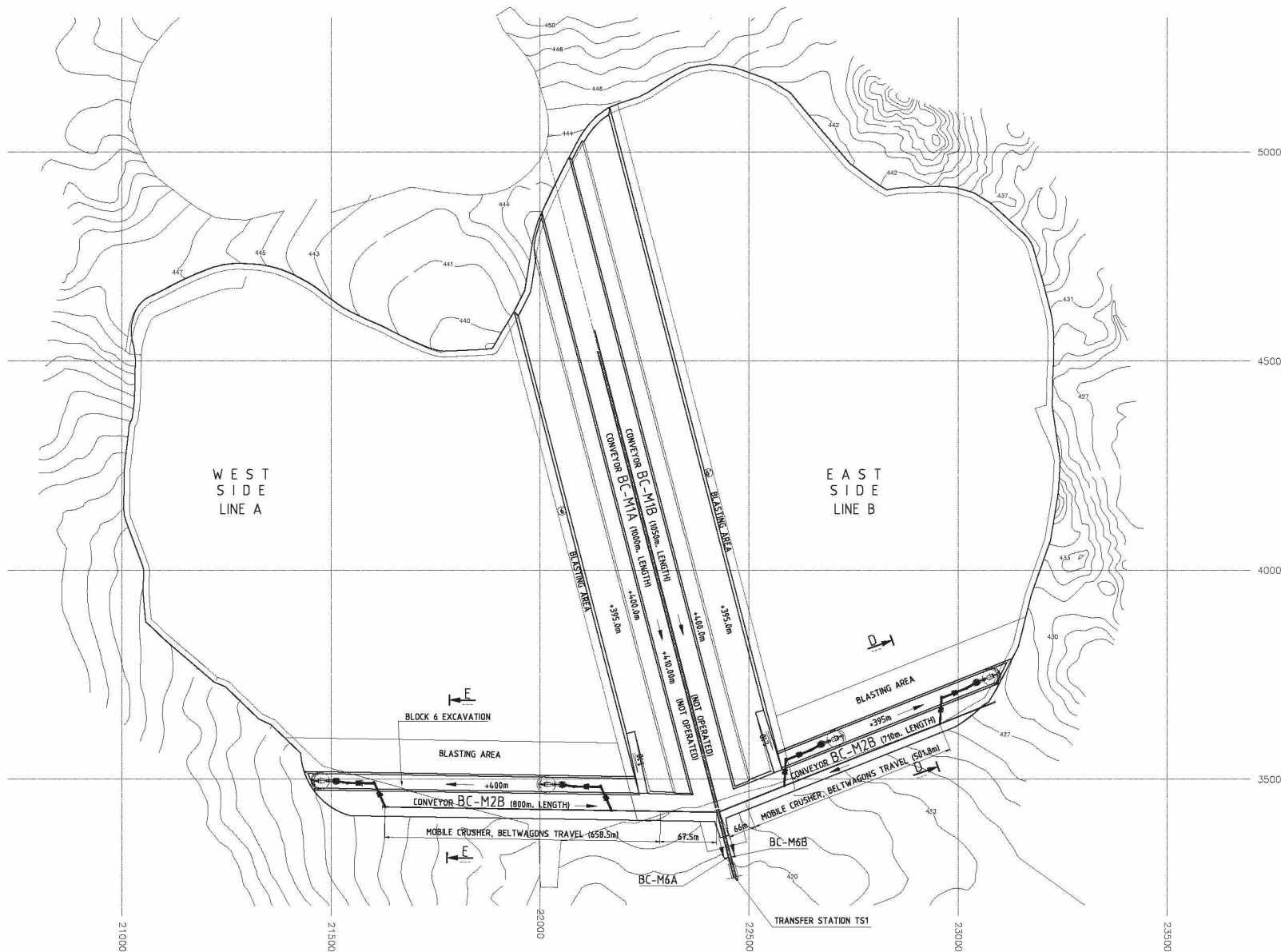
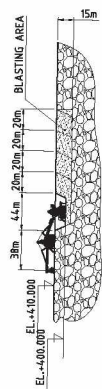

SECTION D-D
SCALE 1:2.5

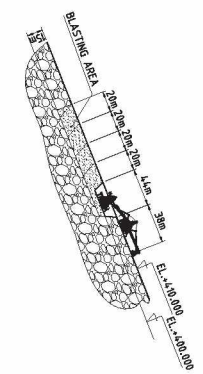

WEST SIDE
LINE A

EAST SIDE
LINE B

ALL LEVEL ARE IN METER.

FOR BID PURPOSE ONLY

REFERENCES	DESCRIPTION	REVISIONS
used in :		
used in :		
used in :		
used in :		
used in :		
used in :		
used in :		

This drawing is an intellectual property that may be transferred or brought into the public domain without the written permission of the author. The author is not allowed to use this drawing as a basis for manufacturing without the written permission of the author.

VOEST-ALPINE Materials Handling GmbH & Co KG ZELTWEG

Released for manufacturing	
Date	signed
Designed	Date
Drawn	26.07.2006
Checked	26.07.2006
Signature	CHR
kg	

MINE BENCH DEVELOPMENT (STAGE-7)

P750-AKTOGAI-MINE BENCH-7

0 1

Format DIN A1

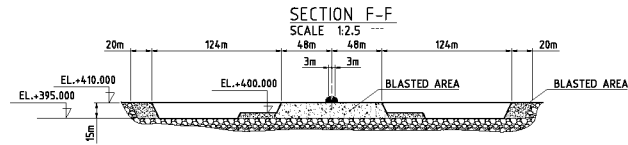

SECTION G-G
SCALE 1:2.5

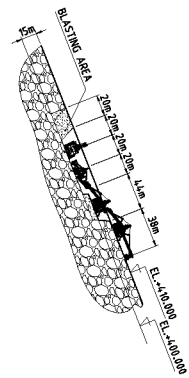

SECTION H-H
SCALE 1:2.5

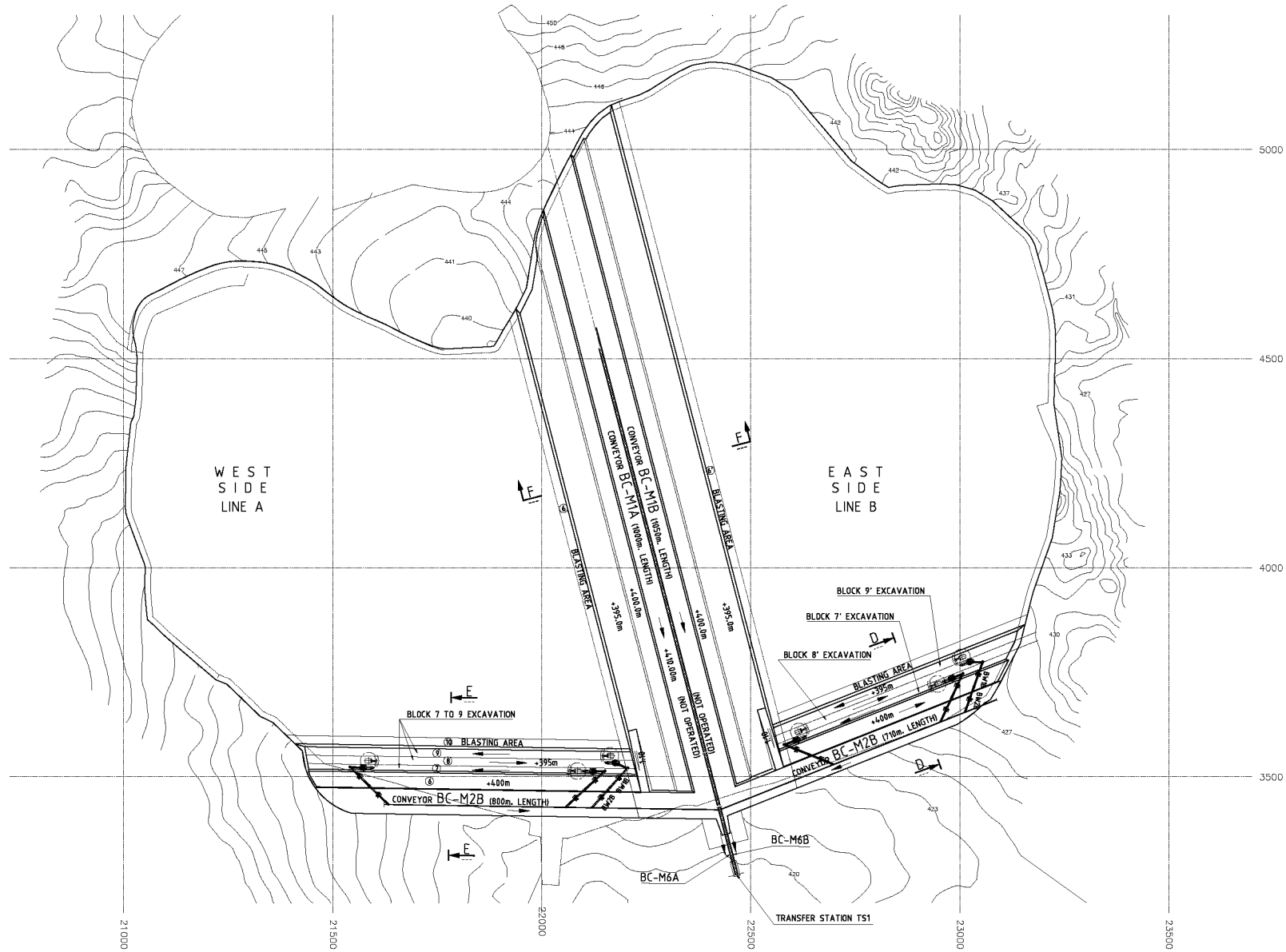
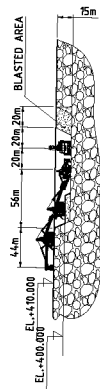

ALL LEVEL ARE IN METER.

FOR BID PURPOSE ONLY

REFERENCES	DESCRIPTION	REVISIONS
used in :		
used in :		
used in :		
used in :		
used in :		
used in :		
used in :		

This drawing is an intellectual property that may be transferred or brought within the reach of third parties without the written permission. Likewise, the receiver is not allowed to use this drawing as a basis for manufacture/variation of the above conditions will result in legal prosecution.
VOEST-ALPINE Materials Handling GmbH & Co KG ZILTWEG

THE KAZAKHNYI MINE
Materials Handling

MINE BENCH DEVELOPMENT (STAGE-8)

Released for manufacturing

Checked	Date	Drawn	Scale
26.07.2006		AM	1:5,12.5
Checked	Date	Checked	Checked
KHR	26.07.2006	KHR	

kg

0 1

Format: DIN A1

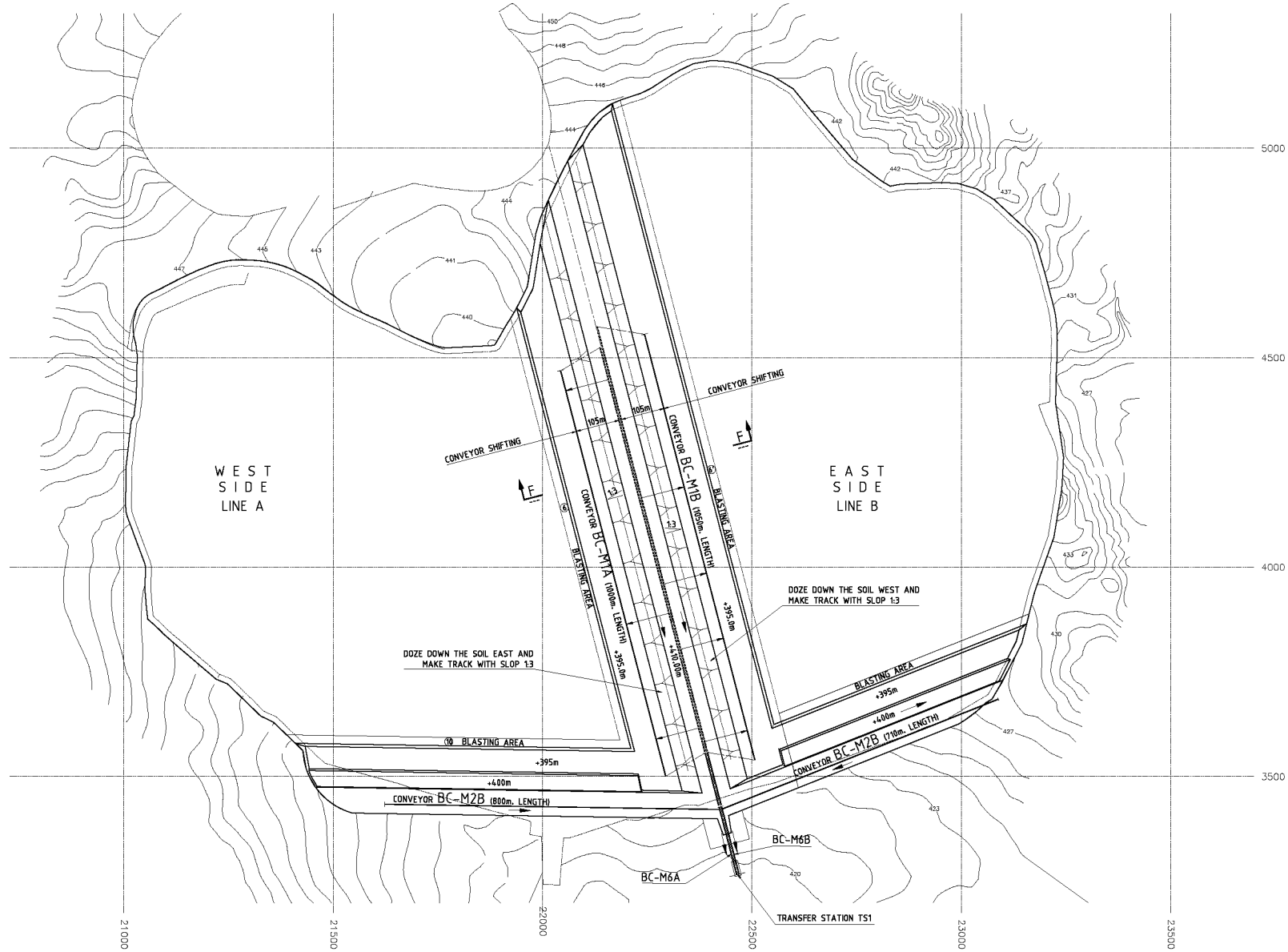
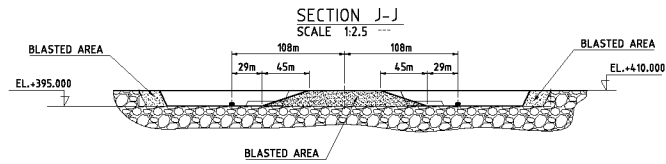

ALL LEVEL ARE IN METER.

REFERENCES	DESCRIPTION	REVISIONS
used in :		
used in :		
used in :		
used in :		
used in :		
used in :		
used in :		

FOR BID PURPOSE ONLY

This drawing is an intellectual property that may be transferred or brought within the reach of third parties without the written permission. Likewise, the material is not allowed to be used for manufacturing without the written permission of the above mentioned company.

VOEST-ALPINE Materials Handling GmbH & Co KG ZELTWEG

THE KAZAKHSTAN MINE
MINE BENCH DEVELOPMENT
(STAGE-9)

Released for manufacturing
Date: _____
Signature: _____

Checked	Date	Name	1:5,12.5
26.07.2006	AM		
26.07.2006	KPR		

Scale: kg
Drawing: 0 1
Format: DIN A1

SECTION K-K
SCALE 1:2.5

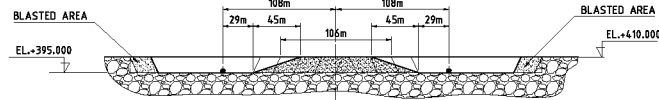

SECTION M-M
SCALE 1:2.5

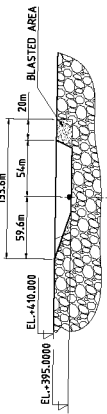

SECTION L-L
SCALE 1:2.5

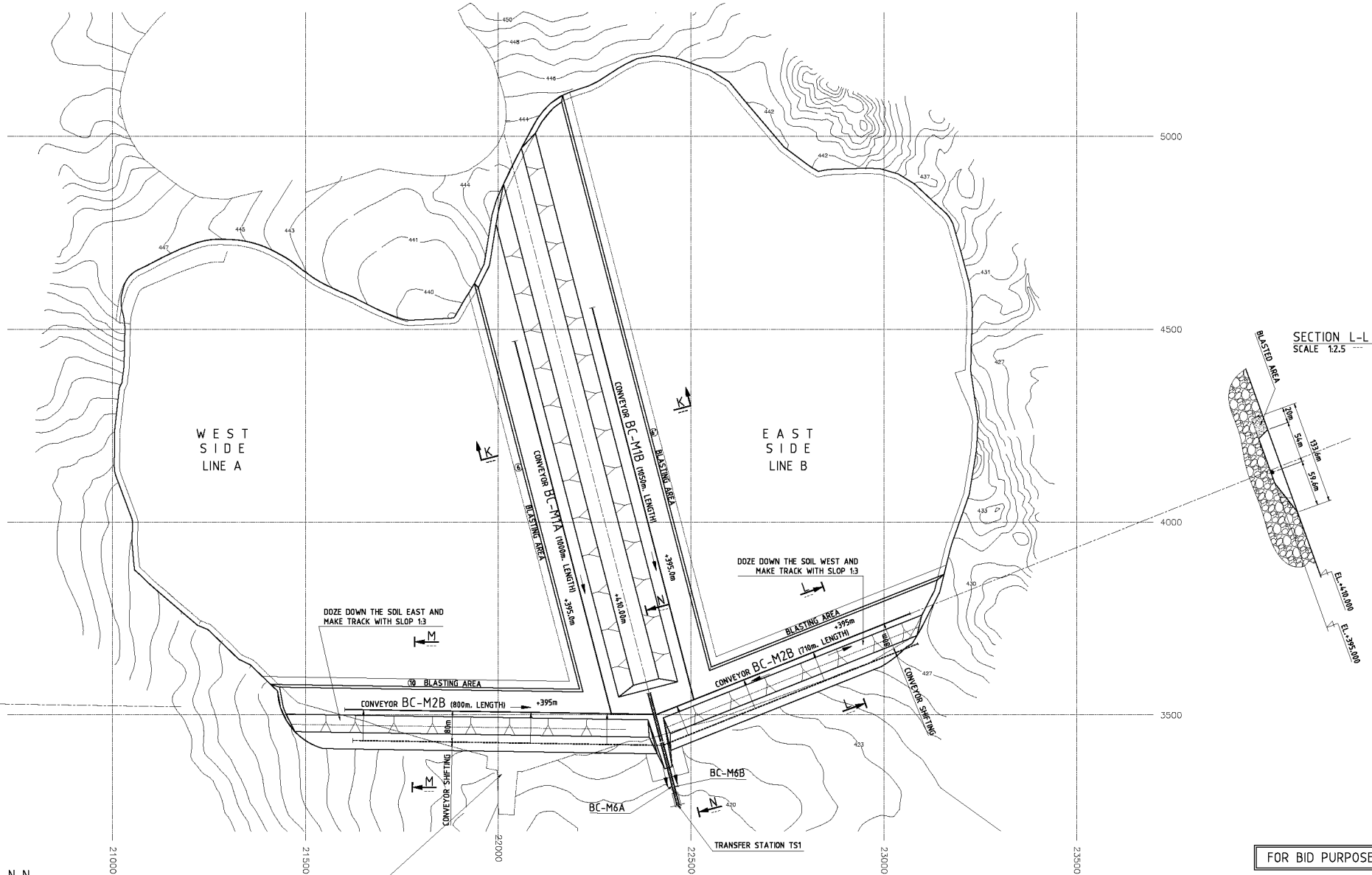
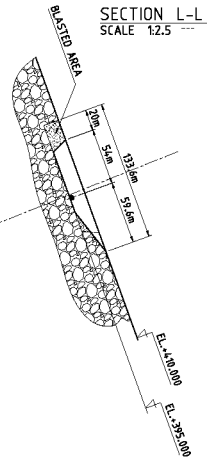

SECTION N-N
SCALE 1:2.5

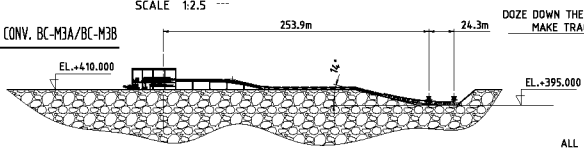

FOR BID PURPOSE ONLY

REFERENCES	DESCRIPTION	REVISIONS
used in :		
used in :		
used in :		
used in :		
used in :		
used in :		
used in :		

This drawing is an intellectual property that may be transferred or brought within the reach of third parties without our written permission. Likewise, the material is not allowed to be used as a basis for manufacture without the above conditions will result in legal prosecution.

VOEST-ALPINE Materials Handling GmbH & Co KG ZELTWEG

Released for manufacturing	
Date	1.5.12.5
Drawn	AM
Checked	CHR
Signature	kg

THE KAZAKHNY'S MINE
MINE BENCH DEVELOPMENT
(STAGE-10)

P750-AKTOGAI-MINE BENCH-10

0 1

Format DIN A1

ALL LEVEL ARE IN METER.

SECTION P-P
SCALE 1:2.5

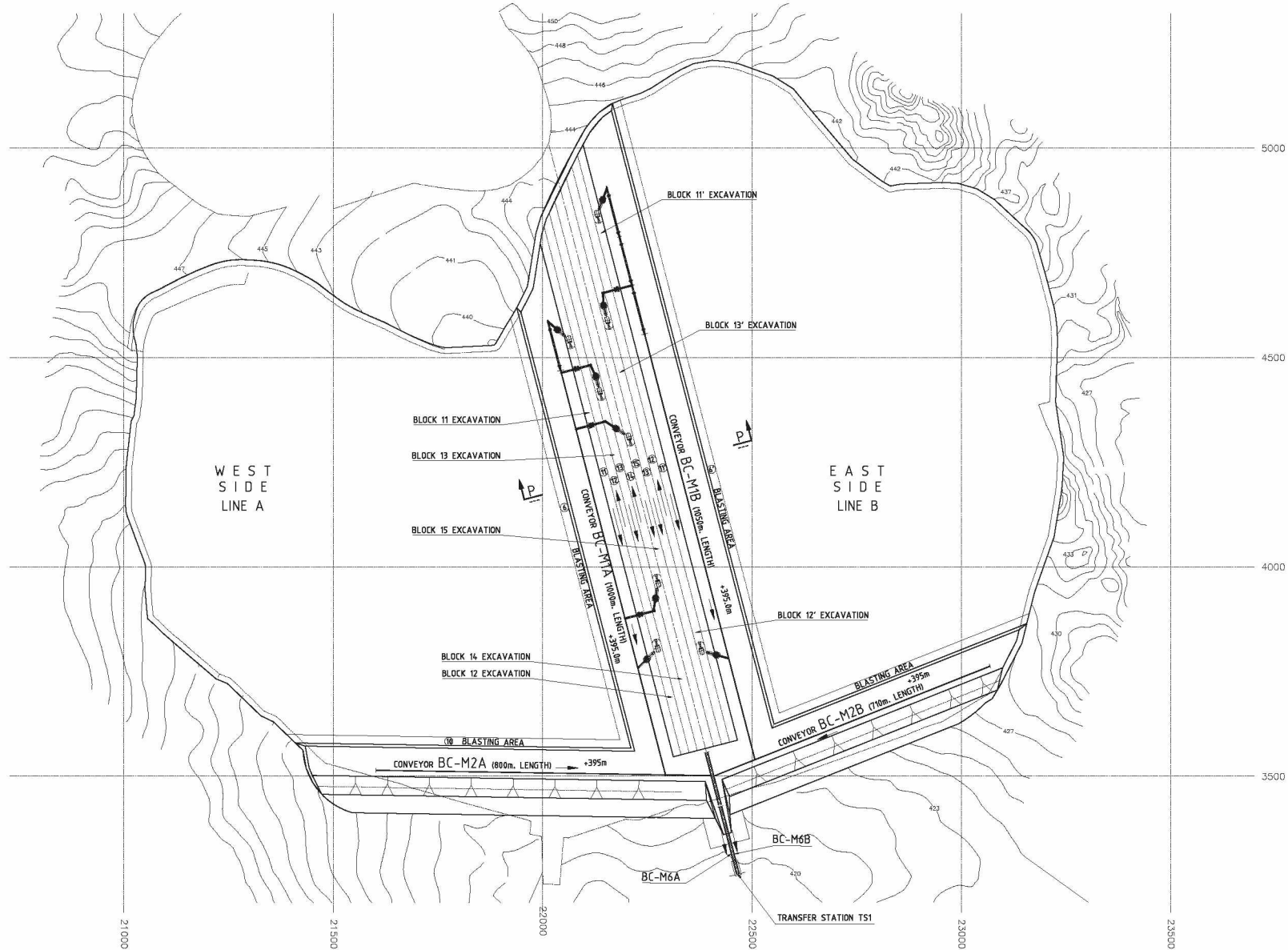
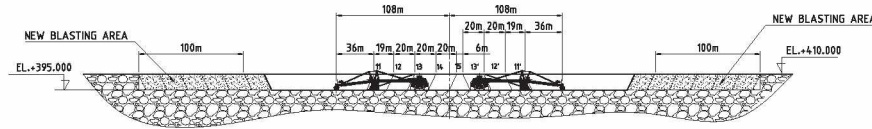

ALL LEVEL ARE IN METER.

REFERENCES	DESCRIPTION	REVISIONS
used in :		
used in :		
used in :		
used in :		
used in :		
used in :		
used in :		

FOR BID PURPOSE ONLY

This drawing is an intellectual property that may be reproduced or transferred by or brought within the reach of third parties without our written permission. Likewise, the reader is not allowed to use this drawing as a basis for manufacture. Violation of the above conditions will result in legal prosecution.

VOEST-ALPINE Materials Handling GmbH & Co KG ZELTWEIG

Released for manufacturing			
Date:			
Signature:	Date:	Scale:	1:5,12.5
Materials Handling	28.07.2006	AM	
	28.07.2006	CHR	
Signature:	Date:		kg

MINE BENCH DEVELOPMENT (STAGE-11)

P750-AKT06AI-MINE BENCH-11

0 1

Format: DIN A1

SECTION P1-P1
SCALE 1:2.5

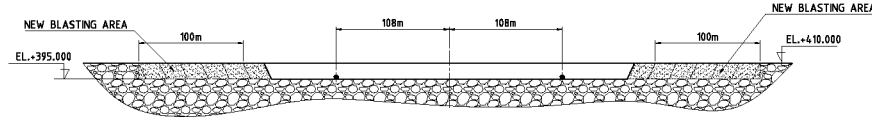

SECTION R1-R1
SCALE 1:2.5

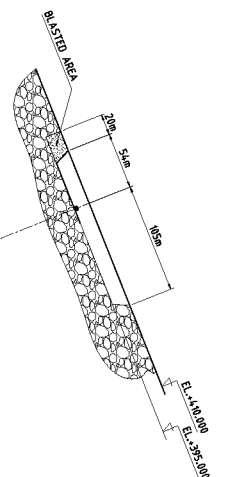

SECTION Q1-Q1
SCALE 1:2.5

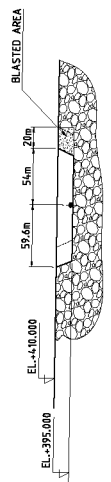

ALL LEVEL ARE IN METER.

FOR BID PURPOSE ONLY

REFERENCES	DESCRIPTION	REVISIONS
used in :		
used in :		
used in :		
used in :		
used in :		
used in :		
used in :		

This drawing is an intellectual property that may be transferred or brought within the reach of third parties without our written permission. Likewise, the receiver is not allowed to use this drawing as a basis for manufacture/violation of the above conditions will result in legal prosecution.
VOEST-ALPINE Materials Handling GmbH & Co KG ZELTWEG

Released for manufacturing	
Date	1.5.12.5
Signature	
Company	Materials Handling
Drawn	26.07.2006 AM
Checked	26.07.2006 KHR
Scale	kg
Project	MINE BENCH DEVELOPMENT (STAGE-12)
Sheet	P750-AKTOGAI-MINE BENCH-12
Size	0 1

Format DIN A1

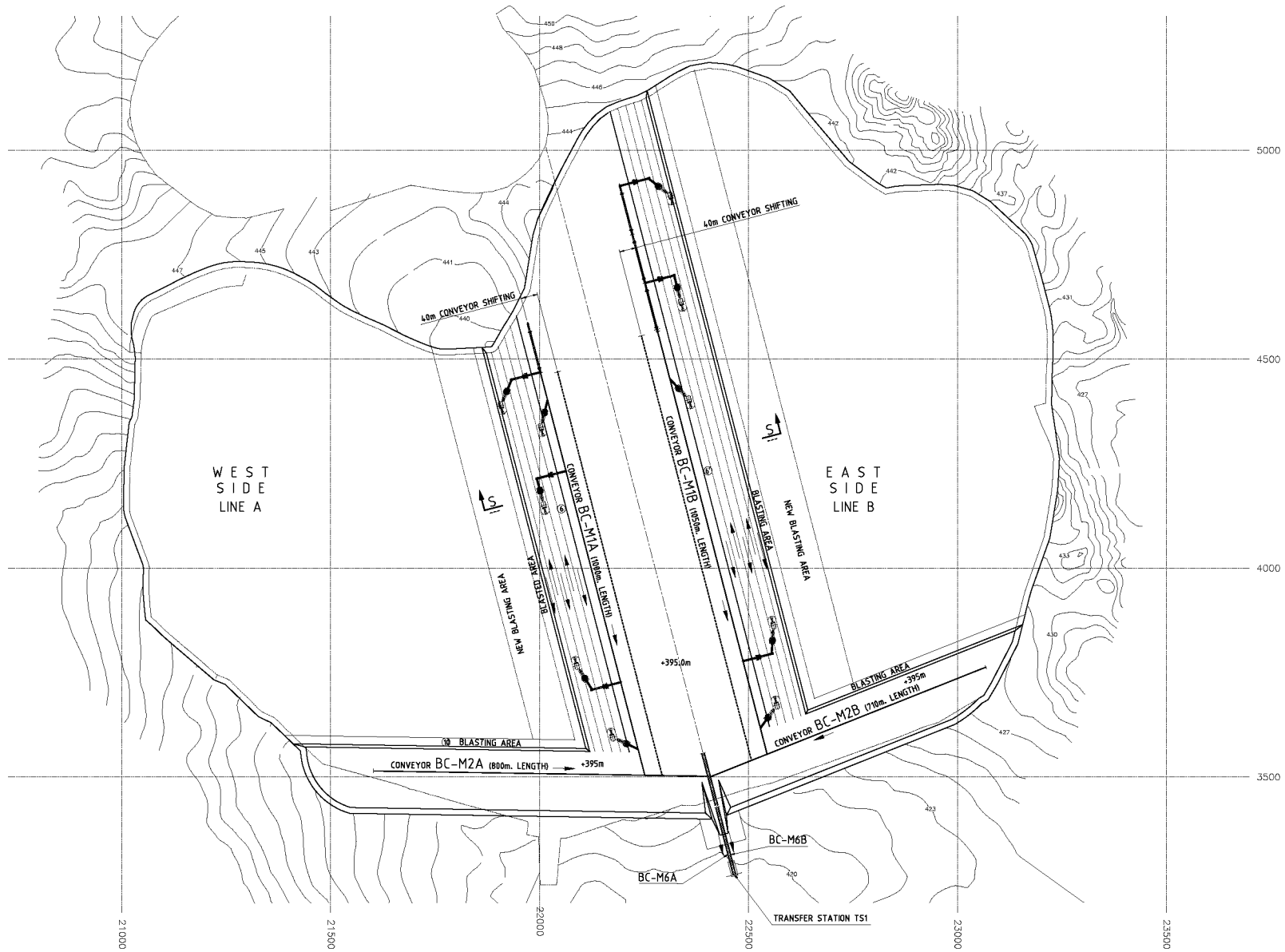
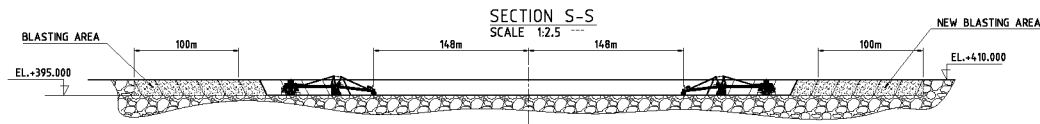

ALL LEVEL ARE IN METER.

REFERENCES	DESCRIPTION	REVISIONS
used in :		
used in :		
used in :		
used in :		
used in :		
used in :		
used in :		

FOR BID PURPOSE ONLY

The drawing is an intellectual property that may not be transferred or reproduced without the express written permission of the author. It is not to be used for any other purpose without the express written permission of the author. Violation of these conditions will result in legal prosecution.

VOEST-ALPINE Materials Handling GmbH & Co KG ZILTWEG

Released for manufacturing	
Date	signed
Checked	Date
Drawn	26.07.2006
Checked	26.07.2006
Scale	1:5, 1:2.5
Author	AM
Checked	CHR
Scale	kg
Drawn	

KAZAKHSTAN'S MINE

MINE BENCH DEVELOPMENT
(STAGE-13)

P750-AKTOGAI-MINE BENCH-13

0 1

Format: DIN A1

SECTION T-T
SCALE 1:5

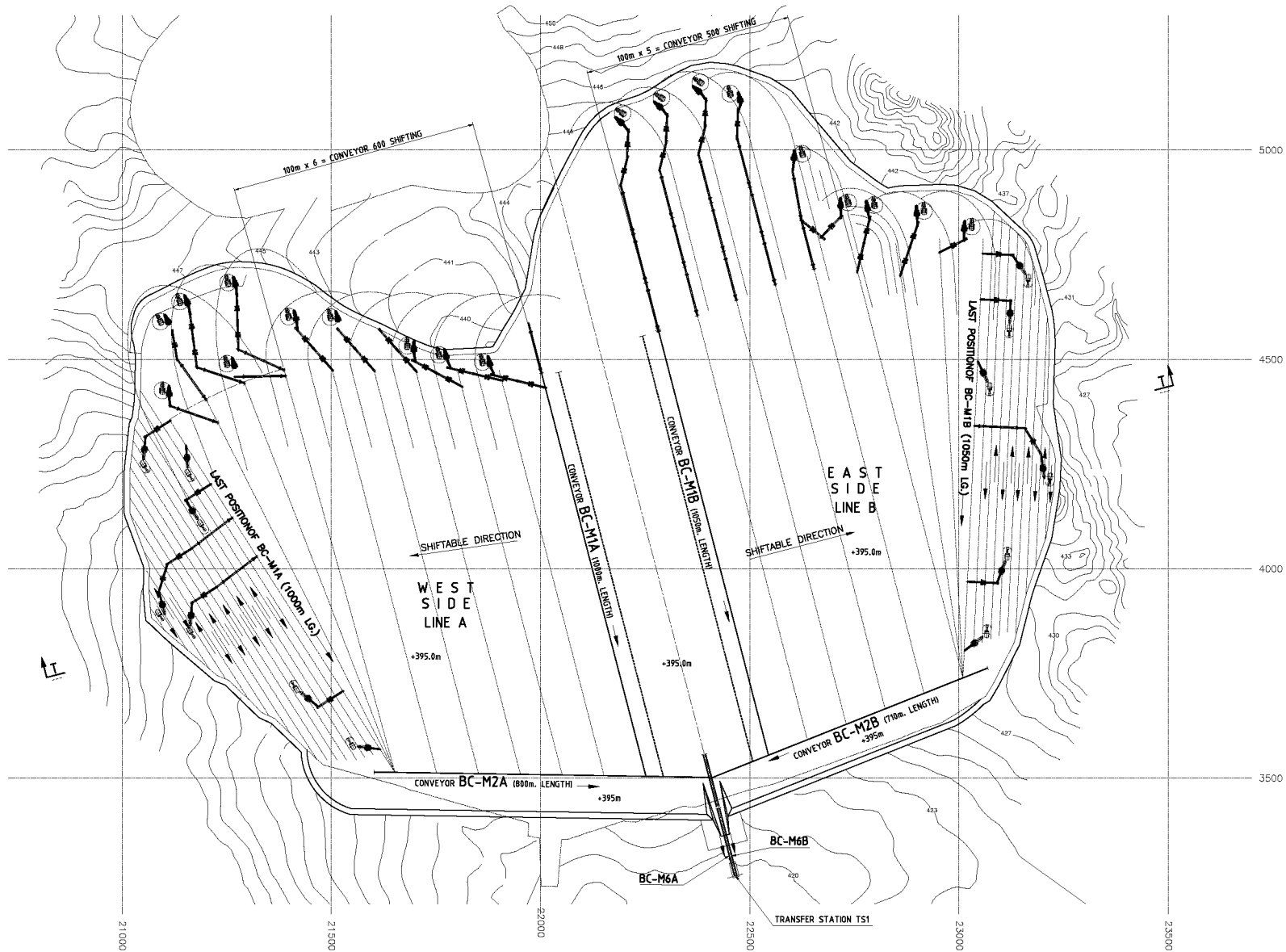
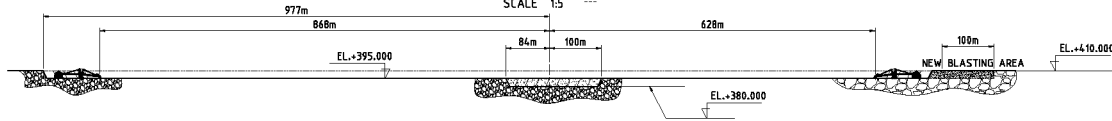

ALL LEVEL ARE IN METER.

REFERENCES	DESCRIPTION
used in:	
used in:	
used in:	
used in:	
used in:	
used in:	
used in:	
used in:	

REVISIONS	DESCRIPTION

The drawing is our intellectual property and may not be reproduced or transmitted in any form or by any means, electronic or mechanical, including photocopying, recording, or by any information storage and retrieval system, without the prior written permission of the copyright owner. The user is not allowed to use this drawing as a basis for manufacture without the prior written permission of the copyright owner.

VOEST-ALPINE Materials Handling GmbH & Co KG ZELTWEG

Materials Handling

WST-MINE

MINE BENCH DEVELOPMENT
(STAGE-14)

P750-AKTOGAI-MINE BENCH-14

0 1

FOR BID PURPOSE ONLY

Released for manufacturing	
Date	signed
Drawn	26.07.2016 AM
Checked	26.07.2016 CPH
Scale	1:5, 1:2.5
Unit	kg
Drawn	